

STARPLUS™

STS Key Systems

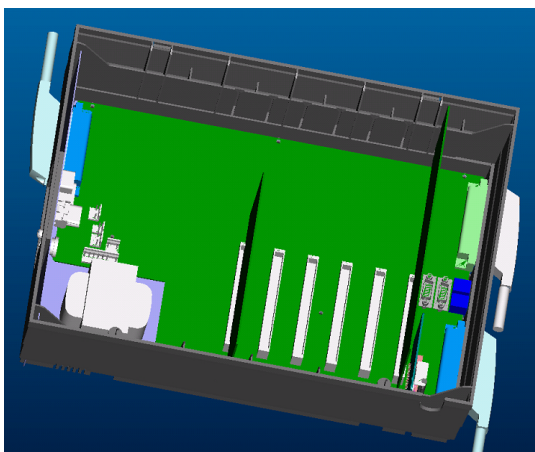

Installation Manual

December 2002 - Issue 1.0

Issue	Release Date	Changes
1	12-02	Initial Release

LIFE SUPPORT APPLICATIONS POLICY

VODAVI Communications Systems products are not authorized for and should not be used within Life Support applications. Life Support systems are equipment intended to support or sustain life and whose failure to perform when properly used in accordance with instructions provided can be reasonably expected to result in significant personal injury or death.

VODAVI Communications Systems warranty is limited to replacement of defective components and does not cover injury to persons or property or other consequential damages.

Copyright © 2002 VODAVI Technology, Inc.

All Rights Reserved

This material is copyrighted by VODAVI Technology, Inc., and may be duplicated by Authorized Dealers only. Any unauthorized reproductions, use or disclosure of this material, or any part thereof, is strictly prohibited and is a violation of the Copyright Laws of the United States (17 U.S.C. Section 101 et. seq.).

VODAVI reserves the right to make changes in specifications at any time and without notice. The information furnished by VODAVI in this material is believed to be accurate and reliable, but is not warranted to be true in all cases.

STARPLUS™ is a Registered trademark of VODAVI Technology, Inc.

seh/2002

Regulatory Information (U.S.A.)

The Federal Communications Commission (FCC) established rules to allow the direct connection of the **STS** to a telephone network. Certain actions must be undertaken or understood before the connection of customer provided equipment is completed.

Telephone Company Notification

Before connecting the **STS** to the telephone network, the local serving telephone company must be given advance notice of intention to use customer provided equipment, and must be provided with the following information:

Telephone Numbers

The telephone numbers to be connected to the system.

STS System Information

- The Ringer Equivalence Number is also located on the KSU: 1.3B
- The USOC jack required for direct interconnection with the telephone network: RJ21

FCC Registration Numbers:

- For systems configured as a key system: (button appearances) 5JYKF06BV70
- For systems configured as a Hybrid system: (dial access codes) 5JYMF06BV70

Incidence of Harm

If the telephone company determines that the customer provided equipment is faulty and possibly causing harm or interruption to the telephone network, it should be disconnected until repairs can be made. If this is not done, the telephone company may temporarily disconnect service.

Changes in Service

The local telephone company may make changes in its communications facilities or procedures. If these changes affect the use of the **STS** or compatibility with the network, the telephone company must give written notice to the user to allow uninterrupted service.

Maintenance Limitations

Maintenance on the **STS** System must be performed only by the manufacturer or its authorized agent. The user may not make any changes and/or repairs except as specifically noted in this manual. If unauthorized alterations or repairs are made, any remaining warranty and the software license for the system will be voided.

Hearing Aid Compatibility

All **STS** Digital Terminals are Hearing Aid Compatible, as defined in Section 68.316 of Part 68 FCC Rules and Regulations.

UL/CSA Safety Compliance

The **STS** System has met all safety requirements and was found in compliance with the Underwriters Laboratories (UL) 1459. This system is authorized to bear the "NRTL/C" marking.

Notice of Compliance

The **STS** System complies with rules regarding radiation and radio frequency emissions by Class A computing devices. In accordance with FCC Standard 15 (Subpart J), the following information is supplied to the end user:



"This equipment generates and uses RF energy and if not installed and used in accordance with the Instruction Manual, may cause interference to Radio Communications. It has been tested and found to comply with the limits for a Class A computing device, pursuant to Subpart J of Part 15 of the FCC Rules, which are designed to provide reasonable protection against such interference, when operated in a commercial environment. Operation of this equipment in a residential area is likely to cause interference, in which case the user, at his own expense, will be required to take whatever measures may be required to correct the interference."

Toll Fraud and DISA Disclaimer

"While this device is designed to be reasonably secure against intrusions from fraudulent callers, it is by no means invulnerable to fraud. Therefore, no express or implied warranty is made against such fraud including interconnection to the long distance network."

"While this device is designed to be reasonably secure against invasion of privacy, it is by no means invulnerable to such invasions. Therefore, no express or implied warranty is made against unlawful or unauthorized utilization which results in the invasion of one's right of privacy."

Vodavi has made every reasonable effort to ensure that this product works in most business environments. However, there may be some environments (RFI and EFI) in which this product may not work properly. In such cases, it is the responsibility of the installer to take the necessary actions to correct the situation.

Contents

1 Introduction

General Information	1-3
System Overview	1-3
System Interface Boards	1-3
CO Circuitry	1-3
System Programming / Database	1-3
Keypad / DSS Console	1-3
Software Upgrades	1-3
Key Service Unit	1-4
Basic Cabinet	1-4
Basic System Configuration	1-4
Main Board Unit	1-5
Single Line Interface Board (2 port)	1-5
Ring Generator Unit	1-5
Expansion Cabinet	1-6
Built-in Power Supply	1-6
Extension Boards	1-6
Digital Telephone Interface Board (8 port)	1-6
Single Line Telephone Interface Board (4 port)	1-7
CO Interface Boards	1-7
Loop Start CO Line Interface Board	1-7
T1 Interface Board	1-7
Add-On Boards	1-8
Message Wait Unit	1-8
Modem Unit	1-8
Phase Lock Loop Unit	1-8

2 System Specifications

Configuration Tables	2-3
System Capacity	2-3
Visual Specifications	2-4
CO Line Buttons	2-4
DSS/BLF Buttons	2-5
Feature/Function Buttons	2-5
Tone Specifications	2-6
Audible Signals	2-6
Miscellaneous Specifications	2-7
System Part Numbers	2-9

3 Installation

Installation Overview	3-3
-----------------------------	-----

Basic Process	3-3
Site Preparation	3-3
General Site Considerations	3-3
Backboard Installation	3-4
Verify On-Site Equipment	3-4
KSU Mounting	3-5
Basic Cabinet	3-5
Expansion Cabinet	3-6
System Preparation	3-6
KSU Grounding	3-6
Grounding Instructions	3-6
Built-in Power Supply	3-7
Battery Backup Unit Installation	3-7
Battery Backup Wiring	3-7
System Backup Duration	3-7
System Battery Replacement - WARNING	3-7
Power Line Surge Protection	3-8
Lightning Protection	3-8
KSU AC Power Plug	3-8
Cable Connections	3-8
PCB Handling and General Installation	3-9
Inserting a PCB	3-9
Card Slot Configuration	3-9
Board Capacity	3-9
Card Slot Positions	3-10
BKSU & Main Board Unit Assembly	3-11
Main Board Unit	3-11
Initialize Default Settings	3-11
Retain Database	3-11
Digital Telephone Interface Board (built-in)	3-12
Loop Start CO Interface Board (with Caller ID)	3-12
Installing CIDU to Built-In LCOB	3-12
Single Line Interface Board (2 Port with built-in Msg Wait)	3-13
Expansion Board Installation	3-14
Digital Telephone Interface Board	3-14
Loop Start CO Interface Board (with Caller ID)	3-14
Installing CIDU Board to LCOB	3-15
Single Line Interface Board - 4 Port	3-15
Message Wait Unit	3-15
T1 Interface Board	3-16
Phase Lock Loop Unit	3-19
DTMF Tone Detection Units	3-20
Flash-Based Voice Mail System	3-20
Installing the Voice Mail Interface Board	3-21
Installing the Memory Expansion Module	3-21

Modem Unit	3-21
Single Line Adapter	3-23
Station/CO Wiring	3-24
Digital & Single Line Wiring	3-24
Digital Stations	3-24
Single Line Stations	3-24
Digital Keypad & Terminal Wiring	3-27
Single Line Telephone Wiring	3-27
Keypad/Headset Installation	3-28
Wall Mounting the Digital Keypad	3-28
Installing a Headset	3-29
System Checkout	3-29
Preliminary Procedures	3-29
Power Up Sequence	3-30

4 Maintenance and Troubleshooting

System Programming and Verification	4-3
Telephone and Terminal Troubleshooting	4-3
Keypad Self Test	4-4
Keypad LCD/LED Test	4-4
Keypad Button Test	4-5
DSS LED/Button Test	4-5
Key Telephones/Terminals	4-6
Single Line Telephones	4-6
DSS/BLF Console	4-7
CO Line Card Functions	4-7
System Functions	4-8
Remote Maintenance	4-9
General Overview	4-9
Maintenance Command Format	4-9
Maintenance Password	4-9
Exit Maintenance	4-9
System Configuration	4-10
Station Configuration	4-11
CO Line Configuration	4-12
Event Trace Buffer	4-13
DTMF Receiver Trace	4-14
Basic Format for Commands	4-14
Examples	4-14
Remote System Monitor	4-14
General Overview	4-14
Monitor Password	4-15
Help Menu	4-15
Dump Memory Data	4-15
Event Trace Mode	4-16

Modify Memory Command	4-17
Exit the Monitor Mode	4-18
SMDR	4-18

Figures

Built-In LCOB with CIDU	3-12
SLIB2 (2 port)	3-13
DTIB (8 Port)	3-14
LCOB with CIDU	3-14
SLIB (4-Port) with MSGU48	3-15
T1IB (24 channel) with two DTRUs	3-16
PLLU Location	3-20
Flash-Based Voice Mail Card	3-21
MODU Installation Location	3-22
SLA (Single Line Adapter)	3-23
Digital Station Jack Wiring	3-27
Single Line Telephone Wiring	3-27
Maintenance Help Menu	4-9
System Configuration	4-10
Station Configuration	4-11
CO Line Configuration	4-12
Help Menu	4-15
Trace Mode Status	4-16
Enable Event Trace	4-17
Event Trace	4-18
SMDR Printout	4-19

Tables

Function Capacity	2-3
Visual Signals - CO Line Buttons	2-4
Visual Signals - DSS/BLF Buttons	2-5
Visual Signals - Feature / Function Buttons	2-5
Signals To Called Station (Digital Station)	2-6
Signals To Calling Station	2-7
Dialing Specifications	2-7
Electrical Specifications	2-8
Environmental Specifications	2-8
Dimensions and Weights	2-8
STS Part Numbers	2-9
T1 Switch Positions	3-17
T1 Ordering Specifications	3-17
T1 Ordering Information	3-17
Call Routing Criteria	3-18
Call Routing Display Format	3-19
Telco to T1IB Interconnect Diagram - Pin Connections	3-19
Power Supply Tests	3-30
Flash Rates	4-5
Key Telephones/Terminals	4-6
Single Line Telephone	4-6
DSS/BLF Console	4-7
CO Line Loop Start Board (LCOB)	4-7
System Functions	4-8
Event Trace Buffer Command	4-13

1

Introduction

This manual provides the information necessary to operate and maintain the *STS* System. The described features are based on the current software release. If any of these features do not work on your system, call your sales representative.

This chapter describes and illustrates the components that may be used with the *STS* System.

» » » » » » » »

NOTES

» » » » » » » »

--	--

General Information

System Overview

The **STS** Key Telephone System supports a maximum configuration of 28 CO/PBX/Centrex lines and 50 station devices. The Basic Key Service Unit (BKSU) and Expansion Key Service Unit (EKSU) accommodates plug-in boards that can be added to expand CO/STA capacity. Both KSUs can generally support a 12x24 configuration for a total capacity of 28x50. The BKSU and EKSU cabinets are installed using industry-standard blocks, jacks, and skinny wire cabling. This, combined with the ability to program the system using a key terminal with a digital display, reduces installation cost and maintenance requirements.

An optional 9600-baud Modem Unit (MODU) facilitates remote programming.

System Interface Boards

The **STS** system can support the following types of interface boards:

- CO card provides 4 loop start lines (LCOB)
- Station card provides interface for 2 or 4 single line telephones or 8 digital key telephones (SLIB or DTIB)
- T-1 Interface Board (T1IB)
- Voice Mail Interface Board (VMIB)

CO Circuitry

All CO interfaces are equipped with transformer barriers for system classification as a FCC fully protected system. Each CO circuit supports rotary (out-pulse) dialing and loop supervision (disconnect detection) under software control. The DTMF tone signals and system supervisory tones can be generated in each keyset or on the main PCB. The **STS** system uses a proprietary tone plan for providing internal progress tones.

System Programming / Database

The system architecture allows system programming changes to be made without interrupting state event software control of normal communications. Call processing continues while the customer database is updated. All programming changes to the customer database programming are made either from a digital terminal (Station 100) or from a terminal connected to either an I/O port or remotely via the optional modem board.

Keyset / DSS Console

The **STS** system features a digital telephone with 24 flexible buttons, 3 interactive soft keys, a 2 x 24 LCD display, and includes speakerphone capabilities. A 48-button DSS console is also available. Each telephone can connect to an optional CTI "box". The optional CTI box provides data connections and transmissions through an RS-232C connection on the phone.

Software Upgrades

Future software enhancements and upgrades are easily retrofitted and installed in the system. This will in most cases, provide backward compatibility with existing Starplus hardware, further reducing the cost to upgrade or add features to an installed system.

Key Service Unit

This diagram illustrates the basic layout of both KSU cabinets, the card slots for the extension boards, and the locations of the Champ connectors.

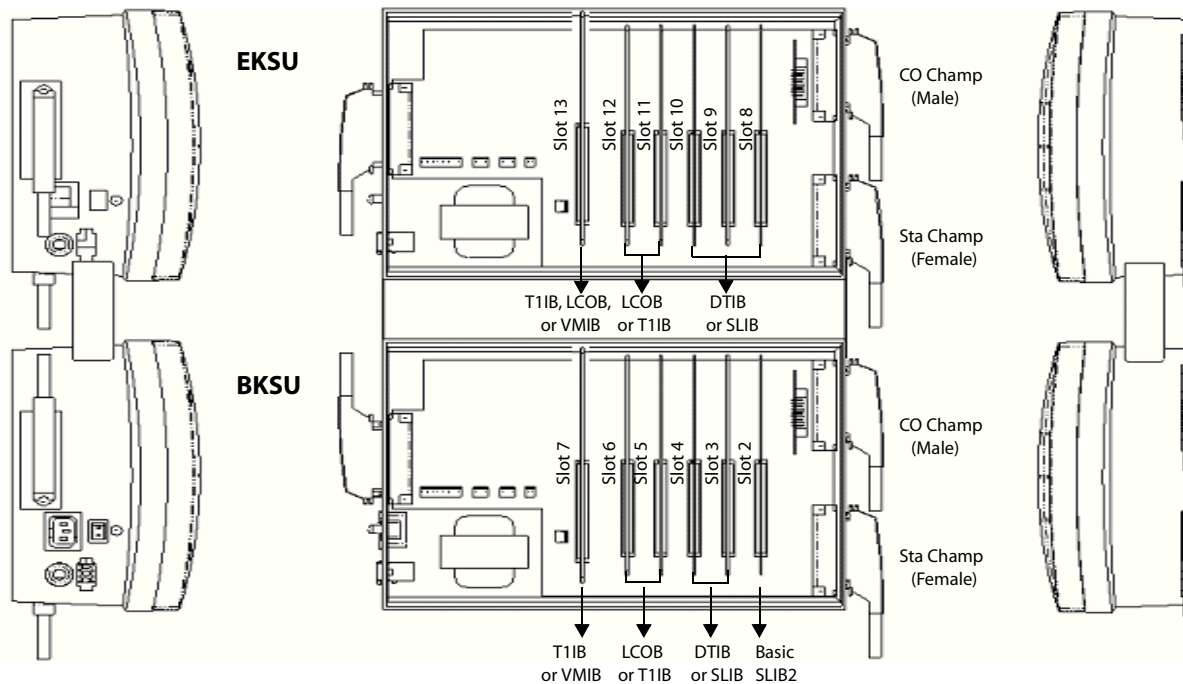

Basic Cabinet

The Basic Key Set Unit (BKSU) has mounting holes so that it can be mounted on the wall. The Main Board Unit (MBU) contains the main CPU – MC68LC302, Memory – the memory size is 1 Mbyte (4Mbit x 2), Data is 512 Kbytes (1 Mbit x 4), and all other system-operating type circuitry to support the maximum configuration of 28 CO lines and 50 stations.

A power supply board is also installed to provide enough power to support all CO lines, stations, and daughter board options. The BKSU has an external power switch to turn power on/off to the BKSU and EKSU.

50-pin amphenol connectors are located on the side of the BKSU to provide the interface for the Station and CO boards.

Basic System Configuration

DEFAULT -- The following extension boards are installed in each BKSU and will support the following types of CO lines / stations:

Standard Boards	Provides ...
DTIB	8 Digital Telephone Lines
SLIB2	2 Single Line Telephone Lines
LCOB	4 Loop Start CO Lines (includes Caller ID Unit)

Main Board Unit

The Main Board Unit (MBU) controls and manages communication between peripheral interface, supervises all resources in the system, controls gain adjustment of PCM signal, generates system tone, and manages call processing of the system.

PERIPHERAL & DAUGHTER BOARDS -- The following can be installed on the BKSU's MBU:

- 1 - Modem Unit
- 2 - Digital Telephone Interface Boards (8 port)
- 1 - T1 Interface Board (24 channels) & 1 Phase Lock Loop Unit
- 2 - Single Line Interface Boards (4 port) & 2 Message Wait Units
- 1 - VM Interface Board (8 port)
- 2 - Loop Start CO Line Boards w/caller ID Unit (4 port)

STANDARD CIRCUITRY -- The following circuitry is standard on the BKSU's MBU:

- 1 - Music Input (MOH/BGM channel 1)
- 1 - Relay (s/w assignable)
- 1 - External page port
- 1 - Memory battery (lithium)
- 2 - DTMF receivers
- 1 - Alarm Sensing Port
- 2 - RS-232 (DB9) (male)

Single Line Interface Board (2 port)

The Single Line Interface Board (SLIB2) that is included with all BKSUs, provides two standard 24V 2500-type Single Line interfaces. Two SLT connections on the right side of the BKSU use RJ11 modular connectors.

The Single Line station circuit specifications of the SLIB2 are as follows:

- One-pair wiring to SLT devices
- 24 V power for both circuits
- RGU power for both circuits
- Built-in Message Wait Unit (MSGU) (2circuit)
- Loop interrupt

Ring Generator Unit

The Ring Generator Unit (RGU) provides the ring voltage to the SLIB circuits to ring the SLT. The RGU also provides the input to the Message Wait source on the SLIB cards. The output of the RGU is 65V AC, 25 Hz. The RGU can support simultaneous ringing for all SLTs associated to the SLIB. The RGU is built-into the SLIB2 and into the SLIB4.

Expansion Cabinet

The Expansion Key Service Unit (EKSU) mounts above the BKSU and is connected via cables that extend the voice and data signaling to and from the BKSU. An integral power supply provides enough power to support all CO lines, stations, and daughter board options.

The EKSU has mounting holes so that it can be mounted on the wall. The station connections are via a 50-pin amphenol connector. This connector is located in the EKSU. CO connections are 50-pin type and are located on the EKSU board.

Built-in Power Supply

A Power Supply is built into each cabinet's MBU.

The Power Supply converts commercial AC power (105 / 117 / 129 V AC @ 47-63 Hz) to $\pm 5V$ DC voltage output, regulates the voltage, and provides the appropriate DC voltage for distribution to other system components.

The Power Supply includes circuitry to charge two externally-connected 12-volt batteries and controls operation of the battery back-up circuits. The Power Supply provides system operating voltages from the batteries if commercial AC power fails.

Extension Boards

These extension boards are capable of supporting the following types of telephones:

Board Name	Function
DTIB	Provides 8 Digital Telephone interfaces
SLIB4	Provides 4 Single Line Telephone interfaces

Digital Telephone Interface Board (8 port)

The Digital Telephone Interface Board (DTIB) provides 2-wire interfaces for telephone connection. The DTIB provides digital voice and data communications to/from digital telephones. This card provides eight standard Digital Telephone Interface circuits and installs in the BKSU or EKSU.

An industry-standard amphenol-type female connector is mounted on the side of the KSU for connection to the station interfaces. One LED is mounted on the PCB to indicate the in use state of the connected telephones. It will turn on when one or more ports are busy.

The digital station circuit specifications: One-pair wiring to digital devices

Single Line Telephone Interface Board (4 port)

The Single Line Telephone Interface Board (SLIB4) provides four standard 24V 2500-type Single Line interfaces. The Single Line station circuit specifications for the SLIB4 are as follows:

- One-pair wiring to SLT devices
- 24 V power for all four circuits
- RGU power for all four circuits
- Optional Message Wait Unit (MSGU) (4 circuit)
- Loop interrupt

CO Interface Boards

The types of CO Interface boards that can be added to the *STS* System are listed in the table and narrative that follow.

Board Name	Function
LCOB	Provides 4 Loop Start CO Lines
T1IB	Provides 24 channels

Loop Start CO Line Interface Board

The optional Loop Start CO Line Interface Board (LCOB) provides four Loop Start CO Lines which support pulse/DTMF signal.

Each interface contains ring and loop current detection circuits, Analog-to-Digital and Digital-to-Analog conversions, and pulse and ground flash signaling circuits.

The LCOB contains LEDs to indicate the in use status of each CO Line. The trunk circuit specifications include: 50-pin amphenol connectors (located on the side of the KSU), Loop detector, and Hybrid CO circuit.

T1 Interface Board

The T1 Interface Board (T1IB) provides the T1 (1.544Mbps, 24-Channel) interface circuit, control circuitry, and synchronous clock control circuits.

DTMF tone detection units can be installed optionally on the T1IB.

The T1IB has eight LEDs on the front edge of the PCB which indicates errors of T1 line, in-use status, and synchronous clock enable status.

Add-On Boards

Add-On Module	Function	Board
MSGU48	Provides message waiting light indication on SLTs	SLIB4
MODU	Provides a 9600-baud modem for local access	MBU
PLLU	Provides clocking for T1 board	MBU

Message Wait Unit

The Message Waiting Unit (MSGU48) provides a 90V message voltage to light the message indicator on single line telephones.

One MSGU can be installed on each SLIB4 (required if message wait indication is needed).

Modem Unit

The Modem Unit (MODU) provides a communication interface for remote maintenance and remote PC Admin.

The MODU allows the system to function as follows:

- Operates at 9600 baud and installs in the BKSU.
- Provides an asynchronous modem for access to the system database and fault reporting features from a remote site.
- May be connected to a pre-selected CO Line through the system-switching matrix.

The MODU port is independent of the standard RS-232C port, allowing system database access, etc., without the need to interrupt the SMDR output.

Phase Lock Loop Unit

The Phase Lock Loop Unit (PLLU) provides clocking for T1, required if T1 card is installed.

The PLLU supplies a 32.768MHz clock to GSXD by either internal clock generator or clock received from the trunk card (e.g. T1IB).

2

System Specifications

This chapter describes the *STS* system specifications. It also provides a part number listing of basic and ancillary components of the system.

» » » » » » » »

NOTES

» » » » » » » »

--	--

Configuration Tables

The following tables and charts describe system capacities and display the configuration flexibility of the system.

System Capacity

Table 2-1: Function Capacity

Item	Description
Account Codes Number of digits per Account Code Number of Account Codes	Up to 12 digits Unlimited-unverified / 256-verified
Attendants Digital DSS/BLF Consoles	Up to 3 stations can be designated as attendant(s). Each DSS/BLF unit requires 1 station port and reduces station capacity by 1. DSS/BLF Maps may not be duplicated at one station. One station may have up to 3 DSS units associated with it.
CO/PBX/Centrex Lines Digital Terminal Stations Standard Single Line Telephones	24 (max) Loop Start (4 per LCOB) 48 (max) Digital Terminals (8 per DTIB) 22 (max) SLTs (4 per SLIB4, 2 per SLIB2)
Conference Circuits Parties per "bridge"	10 Conference "bridges" per system 8 parties per "bridge"
Contacts (multipurpose)	1 (on BKSU)
DISA Circuits:	Unlimited CO lines may be programmed simultaneously
DTMF Receivers DTMF Sender	2 (2 on BKSU, Each SLIB has 2 DTMFs on board) No limit
Hunt Groups Groups Members Types	Software supports 8 Groups Software supports up to 8 stations in each Group Station, Pilot, or All Ring Hunting
I/O Ports	2 (both on BKSU)
Music Channels Music-On-Hold/Background Music inputs	1 Channel per system (on BKSU)
Paging Internal Paging External Paging (one or two way paging)	8 (max) Internal Page Zones (software controlled) 1 (on BKSU)
Speed Dial Memory Station Speed Dial System Speed Dial Total System Speed Dial bins	20 Bins per Station (24 digits) 80 Bins per System (24 digits) 1000

Table 2-1: Function Capacity

Item	Description
UCD Groups Groups Members RAN Announcements Calls In Queue	Software supports 8 Groups 16 Eight RAN announcements per system All CO Lines (28) may be in queue for a UCD Group
Voice Mail Groups Groups Members (ports) Integration Method VM Message Wait VM Disconnect Signal	Software supports 8 Groups Software supports up to 24 stations in each Group In-Band Signaling (DTMF) [420] to turn on, [421] to turn off Programmable 12 digit (DTMF) string. <i>(If no digits are programmed, 15 secs of silence are followed by a busy tone and Loop interrupt.)</i>

Visual Specifications

CO Line Buttons

Table 2-2: Visual Signals - CO Line Buttons

Feature/Function	Flash Rate
Incoming CO Ringing	30 ipm flash
CO Line in the Transfer mode	120 ipm flash
CO Line Recalling	480 ipm flutter
System HOLD	60 ipm double wink
Exclusive HOLD	120 ipm flash
I-HOLD	60 ipm wink
CO Line Queue Call Back	480 ipm flutter
CO Line in use	ON steady
CO line Idle	OFF

DSS/BLF Buttons**Table 2-3: Visual Signals - DSS/BLF Buttons**

Feature / Function	Flash Rate
Off-Hook (busy)	ON steady
Incoming Intercom Ring	120 ipm flutter
Call Announce (H or P mode)	Steady
Message Waiting Call Back	120 ipm flutter
Station in Do Not Disturb	480 ipm double flash
Camp On (by station)	120 ipm flash
Auto Call Back	120 ipm Flash
Station Unavailable	60 ipm flash

Feature/Function Buttons**Table 2-4: Visual Signals - Feature / Function Buttons**

Feature / Function	Flash Rate
ON/OFF Button (while activated)	ON steady
MUTE Button (when activated)	ON steady
SPEED Button (while dialing)	ON momentarily
FLASH Button (while depressed)	None
TRANSFER Button (while depressed)	Steady until TRANSFER complete
HOLD Button (during "T" ICM call)	15 ipm Flash
CONFERENCE - CONFERENCE	ON steady
DND Button - when activated	60 ipm flash
FWD Button All Forward Busy forward No answer forward B/NA forward	ON steady ON steady ON steady ON steady
MSG Button (when activated)	15 ipm flash

Tone Specifications

Audible Signals

The Terminals provide ringing and confidence signals to the user and to calling parties according to [Table 2-5](#) and [Table 2-6](#).

Table 2-5: Signals To Called Station (Digital Station)

Feature (Indication)	Sound In Hz	Occurrence (Cadence)
Incoming CO Line	(*User Selectable)	.8 sec on/2.4 sec off repeated
Intercom Tone Ringing	(*User Selectable)	.4 sec on/.4 sec off/ .4 sec on/2 sec off repeated
Intercom Call Announce (H & P)	935	.2 sec on/.2 sec off; 2 bursts
Transferred CO Line	(*User Selectable)	.8 sec on/2.4 sec off repeated
Line Recall	(*User Selectable)	.2 sec on/.6 sec off repeated
Message Waiting Call Back	(*User Selectable)	.4 sec on/.4 sec off/ .4 sec on/2 sec off repeated
Queued CO Line Call Back	(*User Selectable)	.2 sec on/.6 sec off repeated
Camp On	935	.2 sec burst
Alarm Tone - Repeated - Single (continuous)	701/857 701/857	.25 sec on/.25 sec off; repeated 1.0 sec on; once (every 30-60 secs until alarm is reset.
* Only one tone can be selected by a station at a time. This tone will be used for all signaling that uses the "User Selectable Tone".		

Table 2-6: Signals To Calling Station

Feature (<i>Indication</i>)	Sound In Hz		Occurrence (<i>Cadence</i>)
	Sta	SLT	
Intercom Ring Back Tone	1215/1471	440/480	.5 sec on/2.5 sec off; repeated
Intercom Call Announce	935	935	.2 sec on/.25 sec off; three (3) times
Busy Tone	701	480/620	.5 sec on/.5 sec off; repeated
Error Tone	701	480/620	.25 sec on/.25 sec off; repeated
Intercom dial Tone	420	440/1350	Continuous
DND Tone	701	701	.2 sec on/.2 sec off; three (3) times pause, repeated
Paging Confirmation Tone	935	935	1 second burst
CONFERENCE Time Out Warning Tone	420	701	1 second burst
Programming Confirmation Tone	1471	935	3 short bursts
Programming Error Tone	1471	1471	.25 sec on/.25 sec off; six (6) times
Call Waiting	735	735	.5 burst

*Miscellaneous Specifications***Table 2-7: Dialing Specifications**

Item	Specification
CO Type	Loop Start / 600 ohm / current sensing
DTMF Signaling Frequency Deviation Rise Time Duration of DTMF Signal Inter-digit Time	$\pm 1.5\%$ 5ms 100ms (programmable) 100ms (programmable)
Pulse Dialing Break/Make Ratio Dialing Speed	60/40 - 66/33 10-20 pps

Table 2-8: Electrical Specifications

Item	Specification
Contact Rating (multipurpose contacts)	1 amp, 24 VDC
External Page Port Output Impedance Output Power	600Ω @ 0 dbm 5 milliwatt max
Music Source	600Ω input at 2k ohm maximum from music source
Power Supply AC Voltage Input AC Power AC Input Fuse DC Output Voltage	105 -129 Volt AC @47-63Hz 300 watts +5a 250v + 30v

Table 2-9: Environmental Specifications

Item	Degrees (°F)
Operating Temperature	32 - 104
Optimum Operating Temperature	60 - 80
Storage Temperature	-40 - 140
Relative Humidity	5 - 90% (non-condensing)

Table 2-10: Dimensions and Weights

Item	Height		Width		Depth		Weight	
	<i>in</i>	<i>mm</i>	<i>in</i>	<i>mm</i>	<i>in</i>	<i>mm</i>	<i>lbs</i>	<i>kg</i>
KSU (w/o cover)	11.125	283	15	381	4.625	117	11	4.9
Digital Keypad	9.25	234	7.625	194	4.75	121	2	0.9
Digital DSS/BLF Console	9.25	234	4.9	124	3.3	84	2	0.9

System Part Numbers

The following table may be used to order the **STS** system parts that are currently available.

Table 2-11: STS Part Numbers

Description	Part Number
STS Basic Key Service Unit (BKSU)	3500-00
STS Expansion Key Service Unit (EKSU)	3502-01
Caller ID Unit (CIDU)	3531-04
Digital Key Telephone Unit (DKTU) - 24 Button	3515-71
Digital Telephone Interface Board (DTIB) (8 port)	3532-00
DSS - 48 Button	3510-71
DTMF Receiver Unit (DTRU4) (4 circuit)	3031-60
Loop-Start Central Office Board (LCOB) w/caller ID (4 port)	3531-03
Message Wait Unit (MSGU48)	3033-10
Modem Unit (MODU) - 9600 baud	3530-30
Phase Lock Loop Unit (PLLU)	8030-40
Single Line Adapter (SLA)	9854-00
Single Line Telephone Interface Board (SLIB2) (2 port)	3533-01
Single Line Telephone Interface Board (SLIB4) (4 port)	3533-00
T1 Interface Board (T1IB) (24 channel D4AMI / B8ZS)	3531-31
VM Interface Board (VMIB) (Flash-based - 3 hour)	3534-00
VM Interface Board Memory Expansion Module (Flash-based upgrade - addl 6 hrs)	3534-01
VM Interface Board (VMIB) (Pentium-based)	future

3

Installation

This chapter provides the basic system installation and wiring instructions for the *STS*, as well as how to install the optional cards and interface units.

» » » » » » » »

NOTES

» » » » » » » »

--	--

Installation Overview

Basic Process

As with any sophisticated communications device, installation of the **STARPLUS STS** System requires the care and forethought of a competent technician. To assure easy servicing and reliable operation, several factors must be considered when planning the system installation.

The following procedures are provided to help ensure a successful system installation:

- Site Preparation
- KSU and Power Supply (PS) Installation
- PCB Installation
- System Wiring
- Keypad and Terminal Installation
- Basic Installation Check-Out
- System Programming and Verification

To install the **STARPLUS STS** System as quickly and efficiently as possible, complete the following detailed instructions as described.

Site Preparation

General Site Considerations

The first step is to locate an acceptable site for the common equipment (KSUs, boards, etc.). When locating a mounting site for the KSUs, the following points must be considered:

Wall Mounting -- The KSUs are designed for wall mounting and should not be mounted directly to a masonry or plasterboard wall. It is recommended that a minimum of ½-inch plywood backboard be firmly mounted to the wall, and the KSU and MDF be mounted to the backboard.

Dedicated Access -- The location must have access to a *dedicated* 110 Volt AC (±10%), 60 Hz, single-phase circuit with a circuit breaker or fuse rated at 15 amps. A 3-wire parallel blade grounded outlet should be within approximately 6 feet of the lower left rear of the BKSU mounting.

Grounding -- The location must have access to a good earth ground, such as a metallic cold water pipe without non-metallic joints. The ground source should be located as close as possible to the system.

Environment -- The system should be located in an area that is well ventilated with a recommended temperature range of 68°-78° F and a relative humidity range of 5-60% (non-condensing).

Distance Parameters -- The system location should be within 25 feet of the telephone company's termination point. Also, the location should be within the prescribed station loop lengths for all keysets and terminals. If existing cabling is used, its location and conduits should be considered. Station wiring should be in the building. Station ports are not designed for installation outside of the building.

Accessibility -- The location should have adequate accessibility, space, and lighting for future servicing and should consider the need for future expansion.

Hazard Protection -- The system should be located in an area that is protected from flooding, flammable materials, excessive dust and vibration.

Interference -- The site should be away from radio transmitting equipment, arc-welding devices, copying machines, and other electrical equipment that are capable of generating electrical interferences. Operation of this equipment in a residential area is likely to cause interference. In which case the user, at his own expense, is required to take any necessary measures to correct the interference.

Backboard Installation

Material -- A wooden backboard is recommended for all installations and must be installed when the location has masonry or plasterboard walls. A minimum of ½-inch plywood material is sufficient for most installations.

Placement -- The backboard should be mounted at a convenient height, about three feet above the floor and be bolted in various places to distribute the weight of the system.

Clearance -- Space should be available on the bottom side of the backboard for the MDF cabling and for optional equipment such as a music source, battery backup, etc.

System Layout -- It is recommended that the location of each major item be roughly sketched on the backboard as an installation layout.

Verify On-Site Equipment

Once the equipment installation site is identified and a dedicated AC outlet, earth ground, and lighting and ventilation are available:

1. Verify that all equipment required is on-site and was not damaged during shipment.
2. Unpack the KSUs to assure there is no shipping damage.
3. Notice that a mounting template is packed with the BKSU; this template is required later in the installation.
4. Check that the type and quantity of boards received is correct and optional equipment and a Power Line Surge Protector are on-site.

It is not necessary to unpack the individual boards at this time.



If any equipment is damaged or missing, notify the appropriate personnel to correct the situation.

KSU Mounting

The **STARPLUS STS** System consists of a Basic Key Service Unit (BKSU) cabinet. When additional CO lines and stations are needed, the Expansion Key Service Unit (EKSU) cabinet must be mounted above the BKSU. Both units have been designed to be compact and lightweight for easy handling during installation.

Basic Cabinet

The BKSU consists of a plastic frame and cover designed for wall mounting. The KSU must NOT be mounted on a masonry or dry-wall surface; a wooden backboard is required.

A mounting template is included with the BKSU. This template can be used to drill pilot holes for mounting screws. Note that the template provides screw hole locations for the BKSU and EKSU. The BKSU is mounted with three #10 or larger, 1½ inch or longer screws.

1. Drill pilot holes in the locations marked.
2. Insert the screws and tighten, leaving about ½ inch exposed.

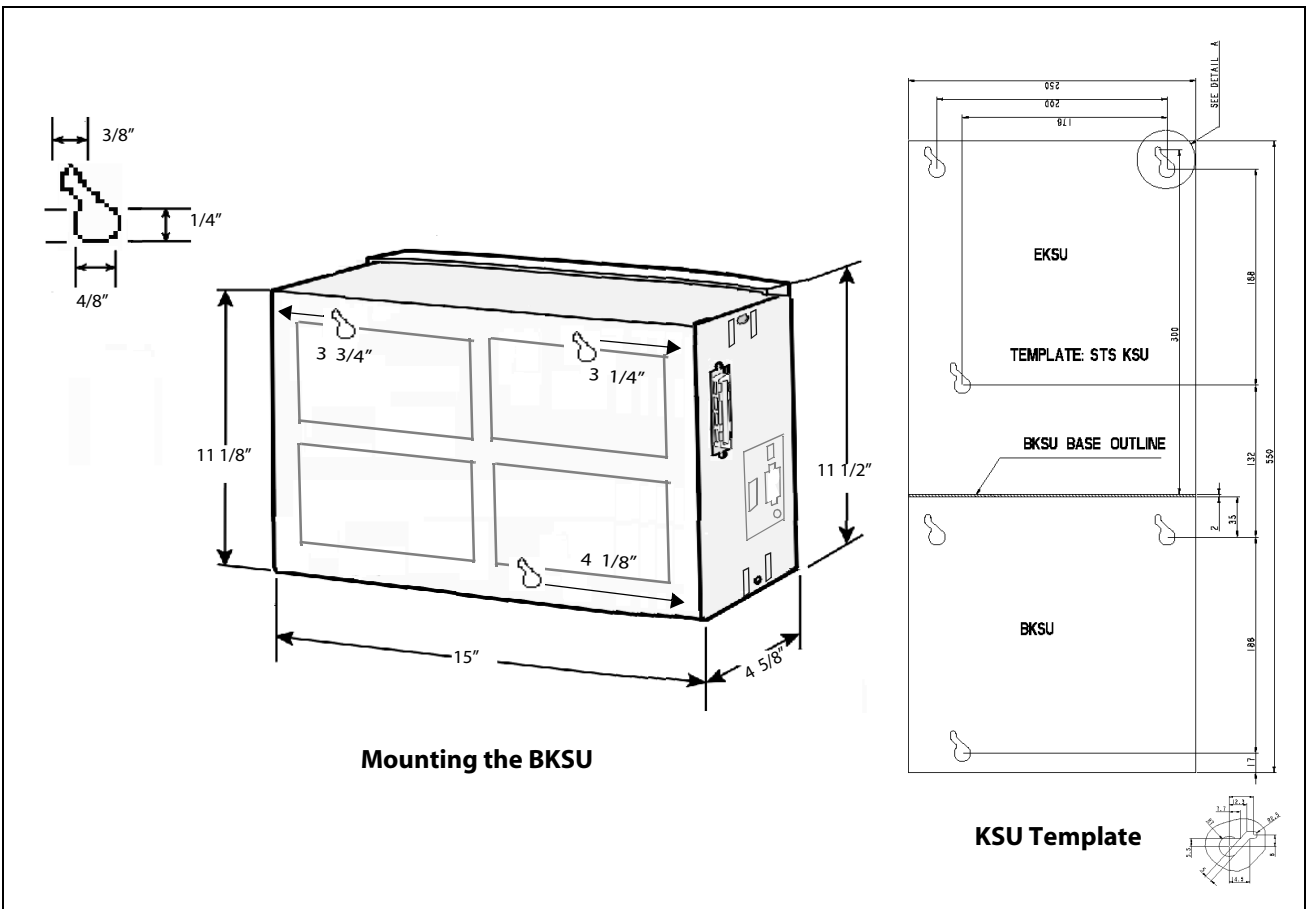

Expansion Cabinet

The EKSU consists of a plastic cover and frame designed for wall mount installation.

» » » The EKSU **must be** mounted above the BKSU.

After positioning the EKSU above the BKSU:

1. Attach the EKSU to the BKSU on both sides, using the four screws and two brackets provided.
2. Mark the location of the two screws to mount the BKSU. The EKSU must NOT be mounted on a masonry or dry wall surface; a wooden backboard is required. The EKSU is mounted with two #10 or larger, 1½ inch or longer screws.
3. Drill pilot holes in the two locations marked, insert screws and tighten, leaving about ½”.
4. Mount the EKSU on the screws and tighten the screws securely.

Interconnection is achieved via an amphenol-type connector and power cable, both included. The amphenol connector connects the EKSU to the BKSU on the left side through connectors labeled EXP.

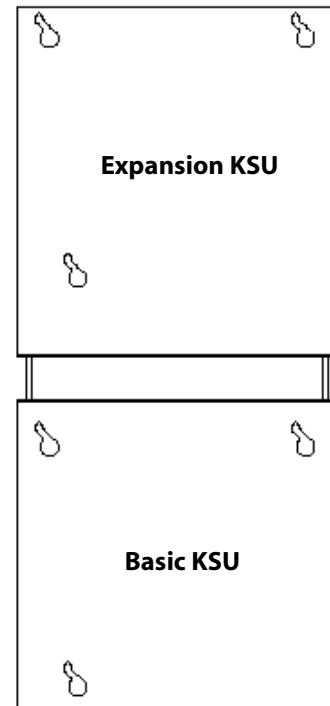

System Preparation

KSU Grounding

To ensure proper system operation and for safety purposes, a good earth ground is required. A metallic COLD water pipe usually provides a reliable ground. Carefully check that the pipe does not contain insulated joints that could isolate the ground. In the absence of a COLD water pipe, a ground rod or other source may be used.

A #12 insulated AWG or larger copper wire should be used between the ground source and the KSU (BKSU and EKSU, respectively). The wire should be kept as short as possible (recommended 25 feet or less).

Grounding Instructions

1. Remove about 1½ inches of insulation from both ends. Attach one end of the wire to the Ground Lug on the lower side of the BKSU and on the lower side of the EKSU by inserting the wire under the lug screw, then tighten the screw securely.
2. Attach the other end of the wire, as appropriate, to the ground source.
3. Take a DC resistance reading and an AC volt reading between the chassis ground point (cold water pipe) and AC ground (third wire AC ground). The limit is 5V AC and 5 Ohms DC resistance. If a higher reading is obtained, choose a different chassis ground point and repeat this step until a suitable ground point is found.



To ensure proper grounding ... make sure to use the brackets provided when attaching an EKSU to the BKSU.

Built-in Power Supply

The built-in Power Supply in each BKSU and EKSU will convert 105V- 129V AC power to $\pm 5V$ DC voltage output. The power capacity of the Power Supply is as follows:

+5V DC	-5V DC	+30V DC	Battery Backup
2.5A	0.5A max	2.5A max	External 4B-BBU

Battery Backup Unit Installation

The Battery Backup Unit (BBU) provides power for the system during a power failure. The BBU connects to the **STS** via the connector on the side of the BKSU.

Battery Backup Wiring

If local AC power fails, the system can be equipped to operate from external batteries. The external batteries must provide 24 Volts DC. This is generally accomplished by connecting two 12-volt batteries to the strip connector on the front of the BBU as shown.

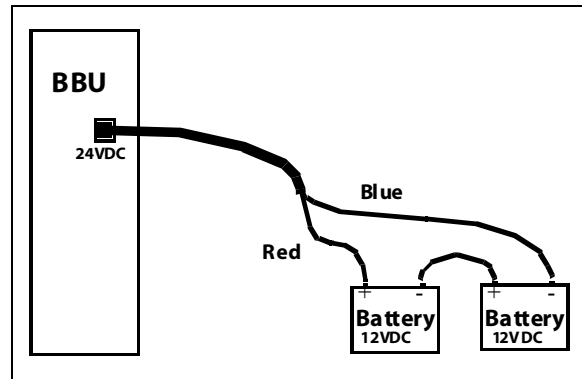

The BBU provides charging current to the batteries during normal AC power operation at a maximum of about 0.5 amp. During battery operation, the BBU discontinues battery operation if AC power is restored or the battery voltage is too low to maintain proper system operation.

System Backup Duration

The length of time the system operates on the batteries is dependent on several elements including: battery charge state, condition of the batteries, capacity of the batteries, and the size of the system (number of station ports).

The following chart gives the approximate backup time for several system sizes and different battery capacities in ampere-hours.

Ports	Battery Capacity	
	10AH	20AH
4	16 Hours	32 Hours
8	8 Hours	16 Hours
16	4 Hours	8 Hours

System Battery Replacement - **WARNING**

In most cases ... the system battery will never need to be replaced.

However, in the event that the battery is determined to be fully discharged, use caution when replacing as it could explode if installed improperly.

- » Replace battery with a similar battery type, as recommended by battery manufacturer.
- » Dispose of the used batteries according to the battery manufacturer's instructions.

Power Line Surge Protection

The AC outlet should be equipped with a power surge protection device or UPS. Systems using such devices are more resistant to damage from power line surges than unprotected systems. Power line surges often occur during normal operations and during violent thunderstorms.

Installation of a surge protector meeting the specifications described in the following paragraph may prevent or minimize the damage resulting from power line surges. The isolation transformer/surge protector should be: 15 amp self-contained unit that plugs into a standard grounded 117V AC wall outlet. The wall outlet must be designed to accept a 3-prong plug (two parallel blades and a ground pin). The protector should be fast and capable of protecting transients greater than 200 volts.

Lightning Protection

The system provides secondary protection per UL 1459 specifications. Primary protection circuitry is the installer's responsibility and should be installed per National Electric Code (NEC).

KSU AC Power Plug

Before plugging the KSU power cord in the AC source (grounded, 3-prong AC outlet required):

1. Verify the power switch of the BKSU is off.
2. Plug the KSU power cord into the AC outlet.
3. Turn the power switch on.

Cable Connections

Champ connectors are mounted on the side of each **STS** BKSU and EKSU - one for CO and Miscellaneous connections, one for Station connections, and one to connect the BKSU and EKSU. Champ connectors include the following:

- **Ferrite Core** -- to improve the line burst immunity on the Champ connector.
- **Cable Tie** -- to secure the Ferrite Core to the Champ connector.

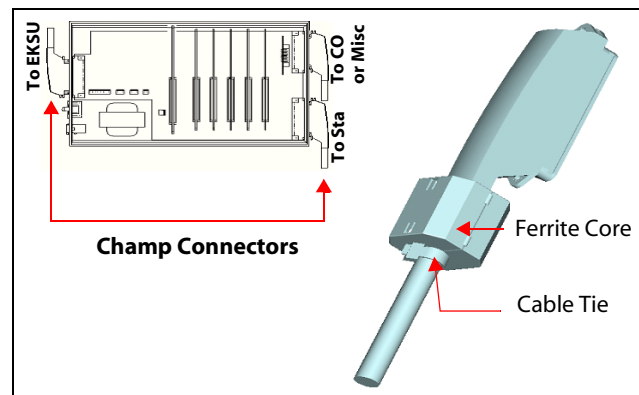

PCB Handling and General Installation



DO NOT install or remove any boards with power applied.

Make sure power is turned off prior to installation or removal of the PCBs

The system cards contain digital circuitry which are extremely reliable, but can be damaged by exposure to excessive static electricity. When handling PCBs, a grounded wrist strap should be used to protect boards from static discharges. Also, use common sense when handling PCBs.

EXAMPLE -- Do not place a PCB in locations where heavy objects might fall on the PCB and damage components.

Inserting a PCB

1. Hold PCB with components facing left, align top and bottom edge of PCB in card guides.
2. Slide the card into the system seat the PCB firmly into the backplane connector.
3. To remove a PCB, reverse the process.

Card Slot Configuration

Board Capacity

The following types of expansion boards may be installed to increase the Station and CO capacity of the **STS** System:

Board	Description	System Capacity
LCOB	4 Loop CO Start Lines (includes Caller ID)	up to 24 CO lines
DTIB	8 Digital Telephone Ports	up to 48 stations
SLIB4	4 Single Line Ports	up to 20 stations
SLIB2	2 Single Line Ports	2 stations
T1IB	24 Channels	--
VMIB	8 Voice Mail Ports	--

Card Slot Positions

This illustration shows the designated slot number for each type of board that can be mounted in the BKSU and EKSU.

IMPORTANT -- Make sure to place the correct board in the appropriate card slot.

Card Slot	Board
8	DTIB / SLIB4
9	DTIB / SLIB4
10	DTIB / SLIB4
11	LCOB / T1
12	LCOB / T1
13	LCOB / T1 / VMIB (Flash- or Pentium-based)

Card Slot	Board
0	DTIB (fixed)
1	LCOB (fixed)
2	SLIB2 - 2 port (default)
3	DTIB / SLIB4
4	DTIB / SLIB4
5	LCOB / T1
6	LCOB / T1
7	T1 / VMIB (Flash- or Pentium-based)

BKSU & Main Board Unit Assembly

The BKSU includes the fixed DTIB in slot 0, a fixed LCOB in slot 1, and a SLIB2 in slot 2. This provides an initial capability of four CO lines, eight digital telephone stations, and two single line telephone stations. Additional cards/boards can be added to increase capability.

The BKSU provides the following miscellaneous features:

- 1 external page port that is connected to a transformer, providing a 600-ohm impedance.
- 1 music input that is connected to a transformer, providing a 600-ohm impedance.
- 1 independent dry relay contact rated at 1 amp, 24V DC.
- 2 DTMF receivers.

These features are provided through the CO amphenol “Champ” connector on the right side of the BKSU. These features are controlled by system software.

Main Board Unit

The Main Board Unit (MBU) is installed in the BKSU at the factory before the shipment. The MBU contains a lithium dry cell to maintain memory and real-time clock functions.

The MBU can be equipped with 3 daughter boards: MODU for modem access to the system, PLLU, and CIDU for Caller ID (refer to *“Expansion Board Installation” on page 3-14*). System software is contained on two chips labeled U1 and U2.

The battery is soldered to the MBU and connected to the circuitry by an ON-OFF dip switch (SW4).

- » Make sure that dip switch SW4 is turned to ON before programming the system database.

Initialize Default Settings

Before programming the system, switch 8 (SW5) should be placed in the ON position and powered off and on to initialize the system database to default.

Retain Database

Once the database is initialized, switch 8 (SW5) should be placed in the OFF position to protect the database. The following diagram shows the dip switch position as they relate to the “database” functions:

		8	7	6	5	4	3	2	1	MBU PCB Marking	Dip Switch Position	Function
OFF	↑									SW8	OFF	Retain the database
ON	↓										ON	Flush the database

Digital Telephone Interface Board (built-in)

The MBU of the BKSU contains a built-in Digital Telephone Interface Board (DTIB) which provides digital voice and data communications to/from digital telephones. The DTIB provides the interface to eight digital telephones. The built-in DTIB is non-removable and does not physically resemble the optional DTIB. It is located in slot 0 on the MBU. The location of slot 0 is an "L" shape that runs vertically along the left side of slot 7 and horizontally across the base of the MBU. Additional DTIBs can be installed to expand the capacity for digital telephones. Refer to ["Digital Telephone Interface Board" on page 3-14](#).

Loop Start CO Interface Board (with Caller ID)

The built-in Loop Start CO Interface Board (LCOB) supports up to four Loop Start Central Office Lines and comes equipped with a Caller ID Unit (CIDU) to detect Caller ID information. The built-in LCOB is non-removable and does not physically resemble the optional LCOB. It is located in slot 1 on the MBU. The location of slot 1 is in the upper right section of the BKSU.

The CIDU provides four Caller ID interfaces for the Built-In LCOB.

Additional LCOBs can be added to provide for increased Loop Start CO Line capability. Refer to ["Loop Start CO Interface Board \(with Caller ID\)" on page 3-14](#).

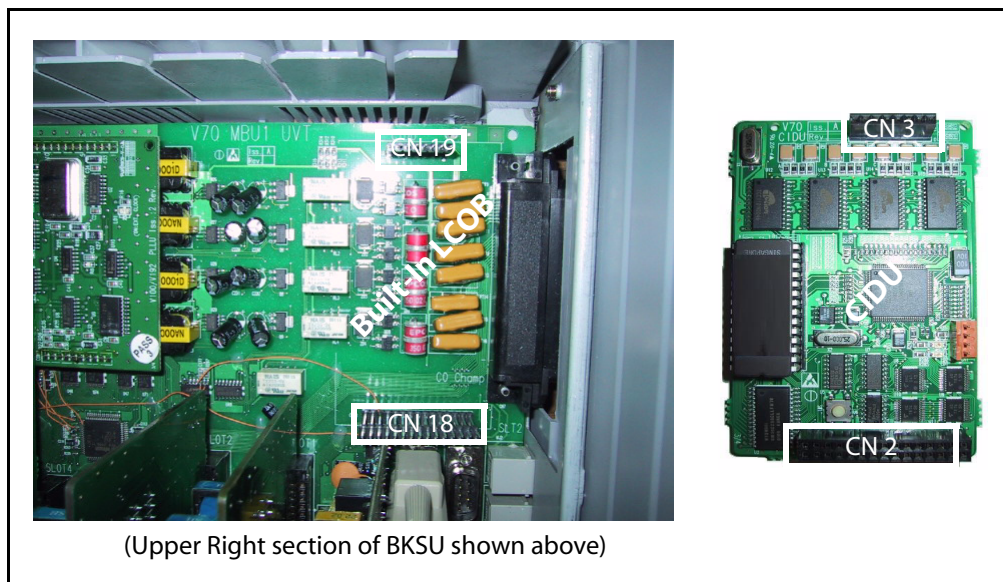

Figure 3-1: Built-In LCOB with CIDU

Installing CIDU to Built-In LCOB

The CIDU may already be installed when you receive your BKSU. If not, use the following procedure to install the CIDU:

1. Unpack the CIDU from its antistatic conductive bag.
2. Locate the CN2 and CN3 connectors on the CIDU.
3. Locate the CN18 and CN19 connectors on the built-in LCOB.
4. Position the CIDU so that the CN2 and CN3 connectors align with the CN18 and CN19, and connectors on the built-in LCOB respectively.
5. Push the CIDU onto these connectors to seat it securely.

Single Line Interface Board (2 Port with built-in Msg Wait)

The Single Line Interface Board (SLIB2) provides the interface to two 2500-type telephones. The SLIB signals interface with industry-standard ringers and message waiting lights. The 2-port SLIB always occupies slot 2 and is standard on the BKSU. It can be removed if necessary by the installer.

The two ports provided by this board are connected to SLT devices by using the two RJ11 modular connectors on the right side of the BKSU.

Additional SLIB devices can be added using one or more optional SLIB4s. Refer to [“Single Line Interface Board - 4 Port” on page 3-15](#).

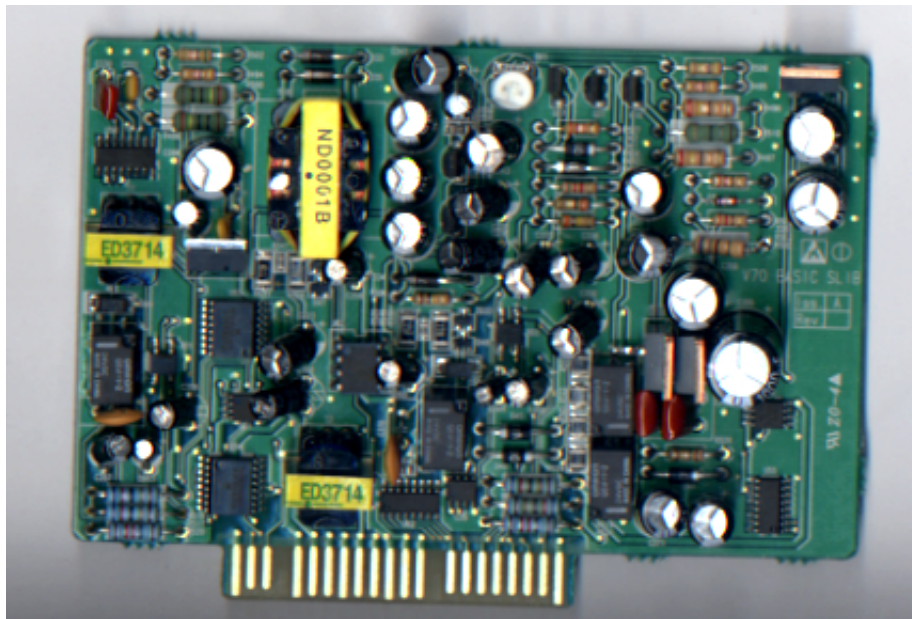

Figure 3-2: SLIB2 (2 port)

Expansion Board Installation

Boards and daughter boards discussed in this section are optional boards that can be used to increase the capacity of your system.

Digital Telephone Interface Board

The optional Digital Telephone Interface Board (DTIB) provides digital voice and data communications to/from digital telephones. The DTIB board provides the interface to eight digital telephones. The card has one LED to indicate off-hook/in use status.

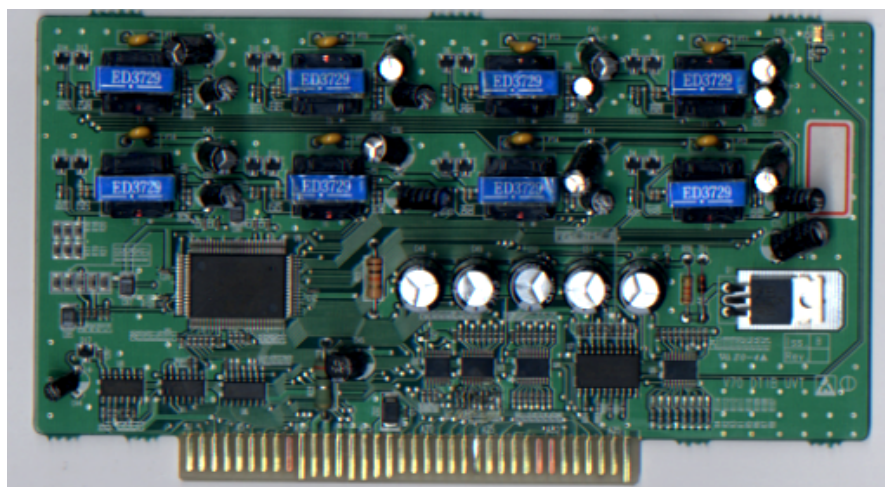

Figure 3-3: DTIB (8 Port)

Loop Start CO Interface Board (with Caller ID)

The optional Loop Start CO Interface Board (LCOB) supports up to four Loop Start Central Office Lines and comes equipped with a Caller ID Unit (CIDU) to detect Caller ID information.

The CIDU provides four Caller ID interfaces for the LCOB.

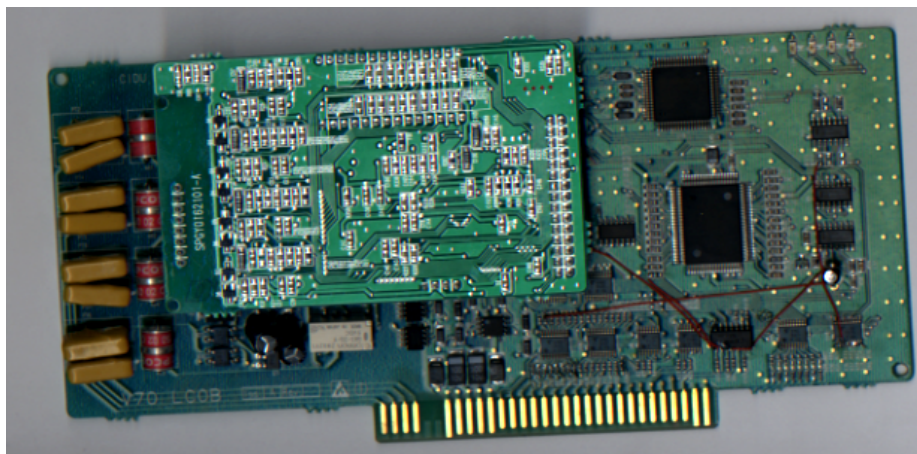

Figure 3-4: LCOB with CIDU

Installing CIDU Board to LCOB

1. Unpack the CIDU from its antistatic conductive bag.
2. Locate the CN2 and CN3 connectors on the CIDU.
3. Locate the CN1 and CN2 connectors on the LCOB.
4. Position CN2 and CN3 on the CIDU to align with CN1 and CN2 on the LCOB, respectively.
5. Push the CIDU onto these connectors to seat it securely.

Single Line Interface Board - 4 Port

The optional Single Line Interface Board (SLIB4) provides the interface to four 2500-type telephones. The SLIB signals interface with industry-standard ringers and message waiting lights. In addition, one LED is mounted on the PCB to indicate the in use state of the connected telephones. It will turn on when one or more ports are busy. The optional 4-port SLIB4 may be added to the BKSU or EKSU to expand the number of single lines stations, and can support an MSGU48 board in a daughter-board-type arrangement.

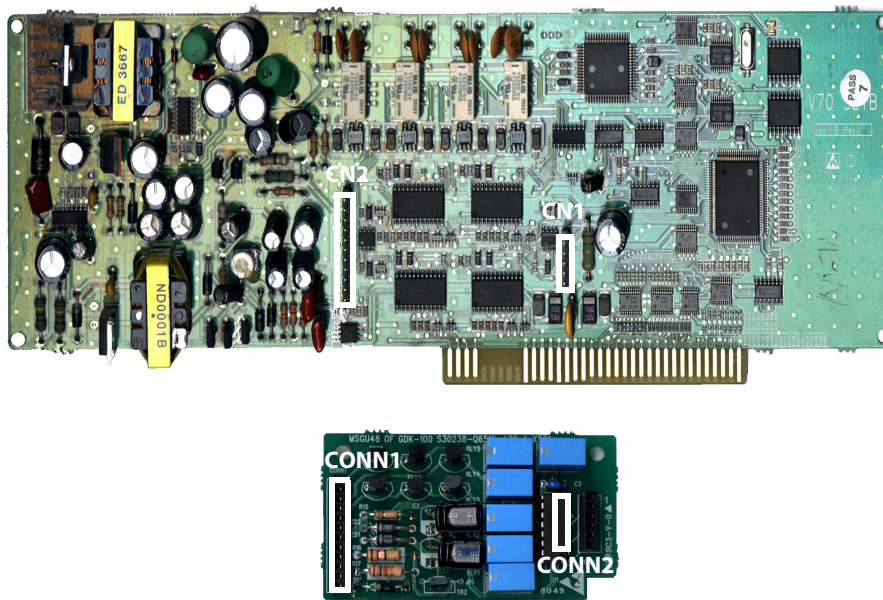

Figure 3-5: SLIB (4-Port) with MSGU48

Message Wait Unit

The Message Wait Unit (MSGU48) provides message wait lamp relay control for message lamp single line telephones. The MSGU48 board mounts as a daughter board on the SLIB4. The SLIB interfaces with mechanical 90V AC ringers and 95V DC lights on 2500-type phone sets.

Installing the MSGU48 to SLIB4:

1. Using a ground strap, unpack the MSGU48 from its antistatic conductive bag.
2. Locate the CONN1 and CONN2 connectors on the MSGU48.
3. Locate the CN1 and CN2 connectors on the SLIB4.
4. Align CONN1 & CONN2 of the MSGU48 to match CN2 & CN1 on the SLIB4, respectively.
5. Push the MSGU48 onto the connectors and ensure it is properly seated.

 Chapter 3 - Installation

T1 Interface Board

The optional T1IB provides the T1 (1.544Mbps, 24 channel) interface circuit, control circuitry, and synchronous clock control circuits. Up to two DTMF tone detection units (DTRU4) can optionally be installed on the T1IB.

The system can be equipped with one T1IB and it can be installed in slots 5, 6, or 7 of the BKSU or in slots 11, 12, or 13 in the EKSU. The Phase Lock Loop Unit (PLLU) must be installed in the BKSU for the T1 card to operate properly.

The T1IB has eight LEDs on the front edge of the PCB which indicate errors of T1 line, in-use status, and synchronous clock enable status.

LED #	Function
LD1	IN USE At least one of the 24 circuits is in use
LD2	RED T1IB is in Red alarm due to any alarm
LD3	Loopback (H/W TEST - normal call processing is not available)
LD4	BLUE T1IB has detected RX_BLUE alarm
LD5	YELLOW: T1IB has detected RX_YELLOW alarm
LD6	OOF T1IB is Out of Frame synchronization
LD7	RCL T1IB receives Carrier Loss (unplugged from the cable)
LD8	CLOCK Clock Enable/Disable

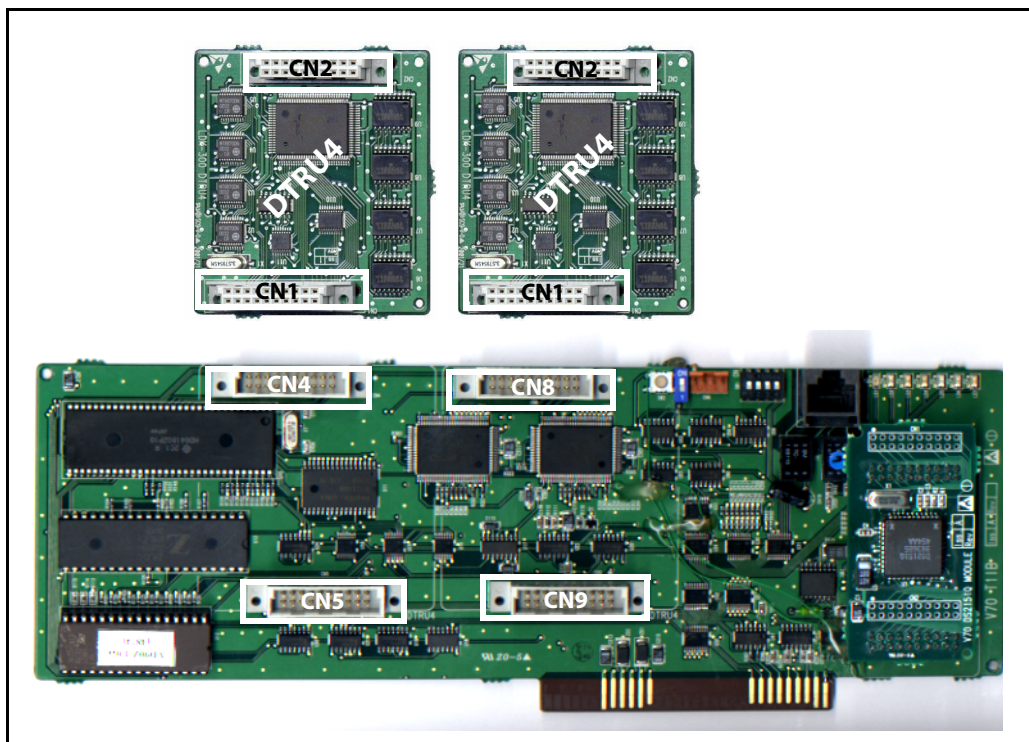

Figure 3-6: T1IB (24 channel) with two DTRUs

The T1IB contains two switches (SW1 and SW3). The clock selection switch (SW3) is used for control of synchronous clock. The Line Build-Out switch (SW1) is controlled by the distance between the **STS** system and a CSU and SW1 #4 is used for loopback control.

The Line Build-Out switch setting is based on distance between the **STS** System and a CSU. The proper switch settings are indicated in the following table. If the CSU is located near the KSU, all LBO switches should be ON.

The SW1 switch #4 of the Line Build-Out switch is used for Loopback control. Its switch is used only for hardware test and must be placed in the ON position for normal operation.

Table 3-1: T1 Switch Positions

Distance	Switch #			
	1	2	3	4
0 to 133 feet	ON	ON	ON	ON
133 to 266 feet	OFF	ON	ON	ON
266 to 399 feet	ON	OFF	ON	ON
399 to 533 feet	OFF	OFF	ON	ON
533 to 655 feet	ON	ON	OFF	ON

T1 Ordering Information: When ordering a T1 circuit from a carrier, request either D4 framing and Alternate Mark Inversion (AMI) Line coding using the superframe (SF) or the Extended Superframe (ESF-B8ZS) format. The following are additional ordering information specifications:

Table 3-2: T1 Ordering Specifications

If ordering...	ANI/DNIS/ DID/TIE	Loop Start/ Ground Start Signaling*
Circuit Information	2 wire	2 wire
Supervisory Signaling	TIE	Loop or Ground
Address Signaling	DTMF	DTMF
Start Dial Indicator	Wink Start	Dial Tone

* ANI/DNIS not available on Loop/Ground start signaling. If Loop Start signaling protocol is ordered, the Central Office does not provide Disconnect Supervision. However if TIE signaling protocol is ordered,

disconnect supervision is provided. The switching equipment processes DNIS numbers received from the T-1 circuit depending on the trunk simulation.

Table 3-3: T1 Ordering Information

T1 Ordering Information	
Ringer Equivalent Number	6.0P
Facility Line Interface	04DU9-B
Jack Type	RJ45

Chapter 3 - Installation

- This board supports standard D4 framing format with robbed bit signaling. Extended Super Frame (ESF) format with B8ZS is also supported.
- The board requires an external CSU unit.
- The T1 board can accept two DTRU4 units in a daughter board type arrangement. Each unit has four DTMF Receivers installed on it.
- The board has an RJ45 connector for connection to a CSU unit.

Functionality Description

- **Automatic Number Identification (ANI)** information from the carrier is treated exactly the same as an inbound ICLID (Caller ID) number. Calls can be routed, placed in the Unanswered Call Table, sent out to the CTI Module port on a keyset, and run through the Number To Name Translation Table. The **STS** system provides call progress tones in the same manner as ICLID.
- **Dialed Number Identification Service (DNIS)** information from the carrier is treated using DID line rules. DNIS calls are routed based on the DID Routing Table.
- **ANI/DNIS** is a combined format, where the system waits for the ANI/DNIS information from the carrier. When it is received, the system routes the call using ICLID processing. If this information is not found in the ICLID Route Tables, the DNIS information is compared to the DID table for a match. The call is then routed based on the DID tables. If a match is not found on either the ANI or DNIS number, the call is routed based on normal CO line operation (CO Ringing Assignments).

The following table summarizes the operation of the system.

Table 3-4: Call Routing Criteria

ANI	DNIS	Operation
N	N	Calls routed based on normal CO operation (CO Ring Assignments).
N	Y	Calls routed based on DID tables with DID operation.
Y	N	Calls routed based on ICLID routing and ICLID operation.
Y*	Y	Calls routed on ICLID first, if no route is found, the DNIS digits are compared to the DID table. If no route is found in the DID table the call is routed based on CO line Ringing Assignments.

**If both ANI and DNIS calls are routed -- the following table summarizes what is displayed at the phone.*



The T1 card accepts ANI/DNIS information in a DTMF format only. Some carriers do not provide ANI or ANI/DNIS in a DTMF format. Consult your local carrier for available options.

Table 3-5: Call Routing Display Format

Route Found	Type of Display	Format
ICLID	ICLID	ANI number placed in the 14-character number field, the DNIS number followed by the name programmed in ICLID translation table placed in the 24-character name field.
DID	ICLID	ANI number placed in 14-character number field. DNIS number followed by programmed name from the DID tables in 24-character name field.
NONE	ICLID	ANI number placed in 14-character number field and the DNIS number is placed in the 24-character name field.

Table 3-6: Telco to T1IB Interconnect Diagram - Pin Connections

Telco	T1IB
RJ45	RJ45
1-->	<--1
2-->	<--2
4-->	<-- 4
5-->	<--5

Phase Lock Loop Unit

The Phase Lock Loop Unit (PLLU) is an option board which generates a 32.768MHz clock synchronized to 1.544MHz from the T1 interface board or internal clock.

This board is required whenever a T1 card is installed in the system. The 32.768MHz clock is provided to CGMD on MBU. It consists of a PLL circuit, PLL Monitoring circuit and clock (from T1 interface board) monitoring circuit.

The PLLU is installed in the upper center of the BKSU. Refer to [Figure 3-7: PLLU Location](#).

Installing the PLLU

1. Unpack the PLLU from its antistatic conductive bag in the packing box.
2. Locate CN14 and CN15 on the MBU.
3. Remove the jumper from pins 12 and 13 on CN5.



This jumper is very important, so don't lose it. LOSS OF JUMPER ON CN5 12 & 13 WILL PREVENT SYSTEM OPERATION. If the PLLU is removed from the MBU board, this jumper needs to be put back onto pins 12 and 13 of this connector or the MBU does not operate properly.

It is recommended that you tape the jumper to the board.

4. Locate the CON1 and CON2 connectors on the PLLU board.
5. Position the PLLU so that CN2 and CN1 match up with CN14 and CN15 respectively. Push the PLLU onto their respective connectors and ensure the PLLU is seated correctly.

PLLU

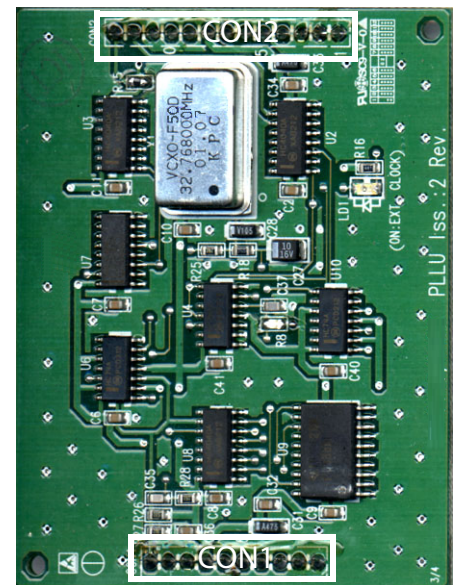

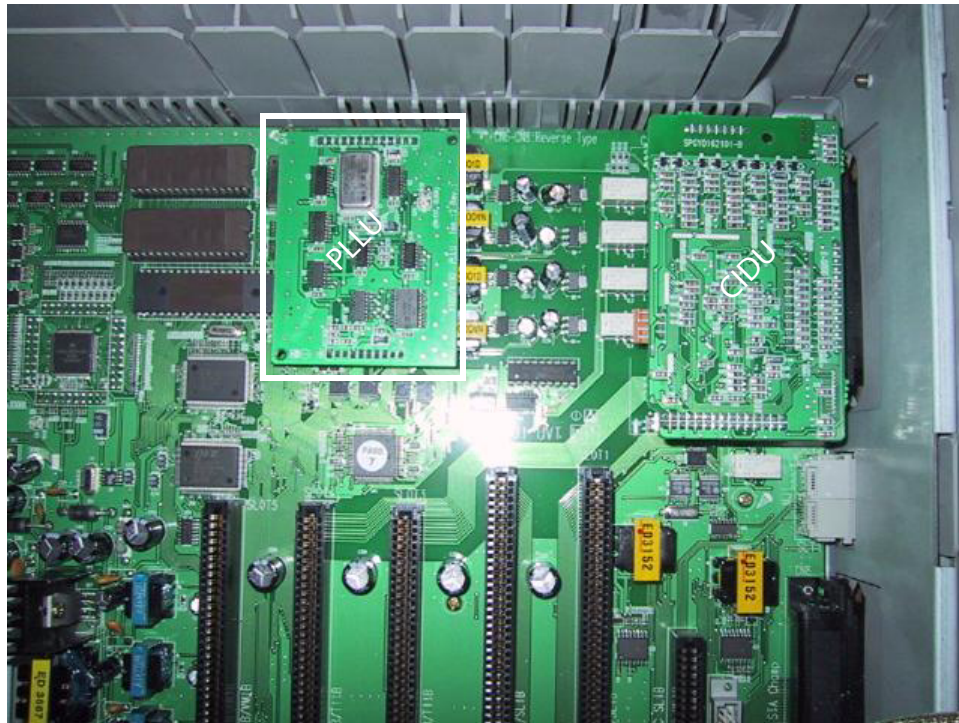

(Upper Right View of BKSU)

Figure 3-7: PLLU Location

DTMF Tone Detection Units

Refer to *"T1IB (24 channel) with two DTRUs"* on page 3-16.

Installing the DTRU4 Modules

1. Unpack the DTRU4 modules from their antistatic conductive bags.
2. Locate the CN1 and CN2 connectors on the DTRU4 modules.
3. Locate the CN4, CN5, CN8 and CN9 connectors on the T1IB.
4. Position one of the DTRU4 modules so that the CN2 and CN1 connectors align with the CN8 and CN9 connectors on the T1IB respectively.
5. Push the DTRU4 module onto these connectors to seat it securely.
6. Position the second DTRU4 module so that the CN2 and CN1 connectors align with the CN4 and CN5 connectors on the T1IB respectively.
7. Push the DTRU4 module onto these connectors to seat it securely.

Flash-Based Voice Mail System

This section describes how to install the *Flash-Based Voice Mail* board.

Installing the Voice Mail Interface Board

The *Flash-Based Voice Mail* Card consists of a printed circuit board. It can be installed into slot 7 in the Basic KSU or slot 13 in the Expansion KSU.

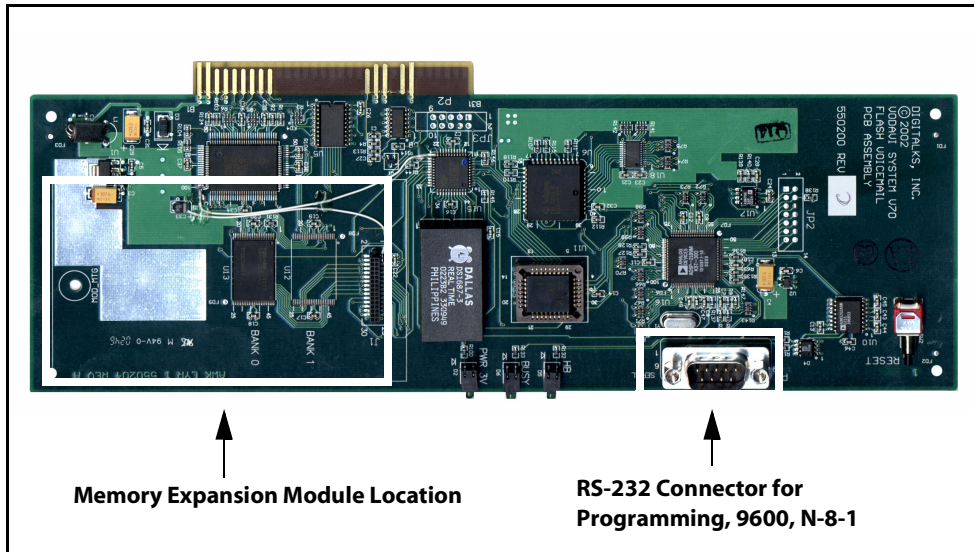

Figure C-8: Flash-Based Voice Mail Card

Installing the Memory Expansion Module

Refer to *Figure C-8: Flash-Based Voice Mail Card* to locate the proper placement for the optional memory expansion module.



You must power down the system before installing the memory expansion module.

Modem Unit

The Modem Unit (MODU) provides an asynchronous modem for access to the system database and remote maintenance.

This module is optionally installed on the BKSU's MBU and includes a 9600 baud modem. The modem may be accessed from any station or CO.

The modem is installed in the lower right of the BKSU. Refer to *Figure 3-9: MODU Installation Location*.

Installing the MODU

1. Using a grounding strap, unpack the MODU from its antistatic bag in the packing box.
2. Locate the MODU connector on the MBU.
3. Locate the CN1 connector on the MODU.
4. Position the MODU so the CN1 matches with CN13 on the MBU.

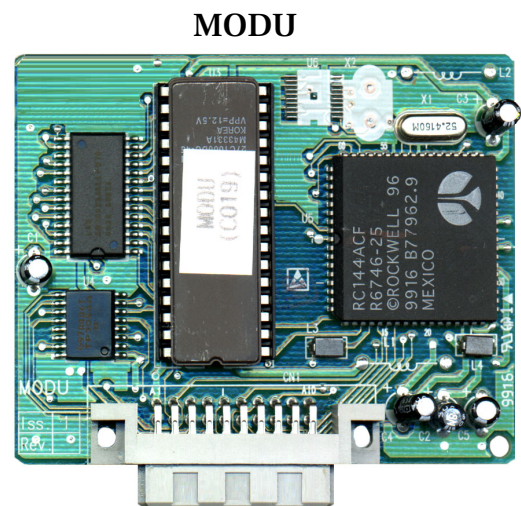

Chapter 3 - Installation

5. Push the MODU onto its connector, making sure it is properly seated.



The modem may not always connect at 9600 bps. If you encounter a situation where you cannot connect at 9600 bps, change your computer's baud rate to 4800 bps.

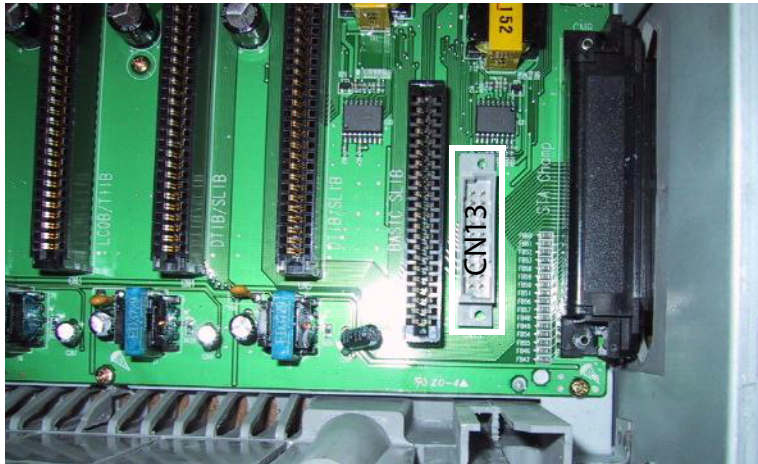

(Lower Right View of BKSU)

Figure 3-9: MODU Installation Location

Single Line Adapter

The optional Single Line Adapter (SLA) device converts standard digital telephone circuits into 2500-type single line telephone interfaces. The device is a stand-alone type that can accommodate up to two digital station ports and convert them into two 2500-DTMP-type SLT circuits.

Wiring / Pinouts / Connections -- The SLA has screw-type connectors for both the digital (DTIB) and analog (SLT) interfaces. Refer to the Single Line Adapter's Installation Guide that is provided with the SLA for additional information.



Figure 3-10: SLA (Single Line Adapter)

Station/CO Wiring

Digital & Single Line Wiring

Digital Stations

Station port numbers are set by the location of the port on the Station Champ connector.

Station ports are numbered consecutively from 100 to 107, 148-149, and 108 to 147.

The first 8 ports are reserved for the built-in DTIB ports, which are always 100-107.

- If an optional DTIB board is installed in the first DTIB/SLIB slot (slot 3), its digital port numbers will be 108-115.
- If two DTIBs are installed in the first two DTIB/SLIB slots (slots 3 & 4), the digital ports will be numbered 100-107 and 108-123.

Single Line Stations

- If an optional SLIB is installed in the first DTIB/SLIB slot (slot 3), the single line ports will be numbered 108-111.
- Ports 148 and 149 are always for the two built-in single line ports.

Care must be taken when wiring stations, to ensure that digital keysets are only wired to digital ports and single line phones are wired to single line ports.

Station Champ Connectors -- The following table shows the port number locations on the BKSU/EKSU Station Champ connectors.

BKSU / EKSU Station #	Pair	Pin #	Color
100 / 126	1	26 1	WH/BL BL/WH
101 / 127	2	27 2	WH/OR OR/WH
102 / 128	3	28 3	WH/GN GN/WH
103 / 129	4	29 4	WH/BN BN/WH
104 / 130	5	30 5	WH/SL SL/WH
105 / 131	6	31 6	RD/BL BL/RD
106 / 132	7	32 7	RD/OR OR/RD
107 / 133	8	33 8	RD/GN GN/RD
110 / 134	9	34 9	RD/BN BN/RD
111 / 135	10	35 10	RD/SL SL/RD
112 / 136	11	36 11	BK/BL BL/BK
113 / 137	12	37 12	BK/OR OR/BK
114 / 138	13	38 13	BK/GN GN/BK
115 / 139	14	39 14	BK/BN BN/BK
116 / 140	15	40 15	BK/SL SL/BK
117 / 141	16	41 16	YL/BL BL/YL
118 / 142	17	42 17	YL/OR OR/YL
119 / 143	18	43 18	YL/GN GN/YL
120 / 144	19	44 19	YL/BN BN/YL
121 / 145	20	45 20	YL/SL SL/YL
122 / 146	21	46 21	VI/BL BL/VI
123 / 147	22	47 22	VI/OR OR/VI
124 / 148	23	48 23	VI/GN GN/VI
125 / 149	24	49 24	VI/BN BN/VI
n/a	25	50 25	VI/SL SL/VI

Chapter 3 - Installation

CO Champ Connectors -- The following table shows the port number locations on the BKSU/EKSU CO Champ connectors.

BKSU / EKSU CO	Pair	Pin #	Color	Description
1 / 13	1	26 1	WH/BL BL/WH	
2 / 14	2	27 2	WH/OR OR/WH	
3 / 15	3	28 3	WH/GN GN/WH	
4 / 16	4	29 4	WH/BN BN/WH	
5 / 17	5	30 5	WH/SL SL/WH	
6 / 18	6	31 6	RD/BL BL/RD	
7 / 19	7	32 7	RD/OR OR/RD	
8 / 20	8	33 8	RD/GN GN/RD	
9 / 21	9	34 9	RD/BN BN/RD	
10 / 22	10	35 10	RD/SL SL/RD	
11 / 23	11	36 11	BK/BL BL/BK	
12 / 24	12	37 12	BK/OR OR/BK	
	13	38 13	BK/GN GN/BK	<i>Blank</i>
	14	39 14	BK/BN BN/BK	<i>Blank</i>
	15	40 15	BK/SL SL/BK	<i>Blank</i>
	16	41 16	YL/BL BL/YL	<i>Blank</i>
	17	42 17	YL/OR OR/YL	<i>Blank</i>
	18	43 18	YL/GN GN/YL	<i>Blank</i>
	19	44 19	YL/BN BN/YL	<i>Blank</i>
	20	45 20	YL/SL SL/YL	Alarm (BKSU only)
	21	46 21	VI/BL BL/VI	--
	22	47 22	VI/OR OR/VI	External Paging (BKSU only)
	23	48 23	VI/GN GN/VI	External MOH (BKSU only)
	24	49 24	VI/BN BN/VI	--
	25	50 25	VI/SL SL/VI	Free Relay (BKSU only)

Digital Keypad & Terminal Wiring

Wiring from the DTIB to the station jack requires a single pair cable (3-pair, category 3 or higher is required). Digitized voice, signaling and battery are sent over this pair.



Only the first pair (green, red) on the jack should be connected to the KSU. No other pairs should be connected.

The following diagram gives details on connections of station jacks to the system. The "Station Champ Connector" table gives the configuration of the 25-pair station connector arrangement and punchdown-type block.

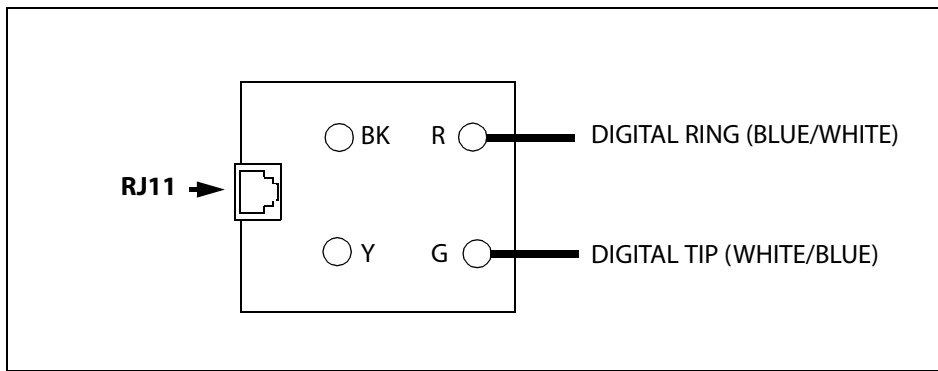

Figure 3-11: Digital Station Jack Wiring

Single Line Telephone Wiring

The SLIB is wired to SLT devices with single pair cabling to provide talk battery, voice and signaling to and from the SLT.

Typical wiring to the SLT jack is shown in the following diagram. The "Station Champ Connectors" table gives the configuration of the station connector arrangement when connected to a punchdown-type block.

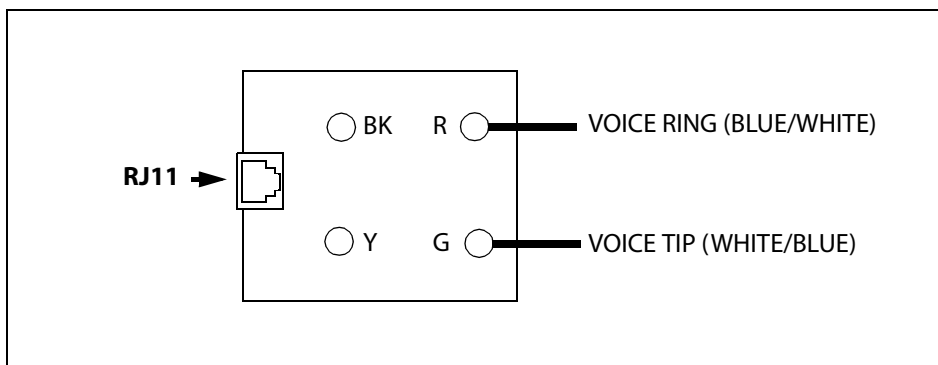

Figure 3-12: Single Line Telephone Wiring

Keypad/Headset Installation

Wall Mounting the Digital Keypad

To wall mount the digital key telephone, use the wall mount bracket and a standard type jack designed for 630-type wall hanging applications provided.

1. Remove handset from cradle and locate the plastic retainer in the bottom of the hookswitch well area.
2. Slowly push the plastic retainer upward until it is free.
3. Locate the tab on the plastic retainer making sure it is toward you, then place it back into its holder,

4. Slide the plastic retainer all the way down into its channel. Part of the retainer remains above its holder to hold the handset secure during use in a wall mount configuration.

5. Turn telephone over and unplug the line cord.

6. Reroute line cord through the access channel on the top of the telephone, -or-

Run line cord through hole provided, and plug into connector on the back of the telephone.

7. Line up the hooks on the top and bottom of the wall mount bracket so they can engage with the slots cut into the bottom of the telephone base. Insert the bottom hooks first.

8. Slide the mounting bracket slowly downwards until the top tabs slide into the top slots and snap into place.

9. Match the two key hole slots on the base plate with the lugs on the 630-A type jack and align the modular connector, then slide the telephone into place.

10. Place the handset onto the retainer.

The **STS** Telephone is now ready to use.

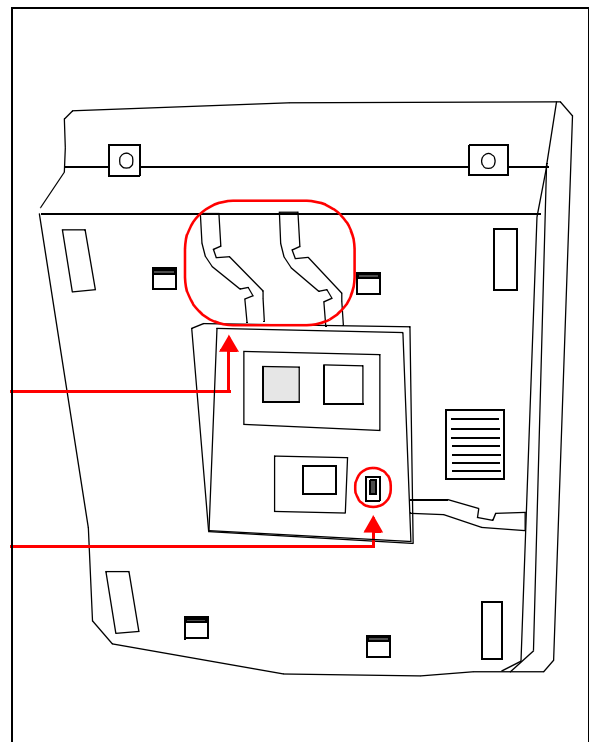

Installing a Headset

The **STARPLUS STS** digital key telephone is designed to operate with industry-standard 2.5mm connector headset adapters and operator headsets. Each digital key station can be individually programmed for Headset operation. When programmed, a headset with its adapter box may be connected to a key telephone station for Headset use.

To install a headset, either:

Insert the headset's 2.5mm plug into the 2.5mm connector on the left side of the keyset

-or-

1. Remove the handset cord from the bottom of the Key Telephone unit.
2. Plug the Headset Adapter cord into the vacant handset jack on the Key Telephone base.
3. Then plug the handset and the Headset into the modular jacks of the Adapter box.
This allows handset or headset operation as desired by switching the selector switch on the Adaptor box. Speakerphone operation is disabled while a station is in Headset Mode.
4. Leaving the handset in place, connect a modular headset to the handset jack located on the side of the telephone.

REQUIREMENT -- For headset to operate properly, make sure to use a Headset Unit that complies with the current industry standards.

System Checkout

Prior to actual power up and initialization, check out the **STS** System to avoid start up delays or improper loading. A step-by-step checklist is provided for this purpose.

Preliminary Procedures

1. Make sure the Basic Key Service Unit (BKSU) is properly grounded to a cold water pipe or earth ground.
2. Verify that all expander modules are firmly seated onto their connectors.
3. Inspect the Main Distribution Frame (MDF) for shorted wiring and improper polarity that would affect the Digital Terminal or DSS console.
4. Make certain the lithium battery switch (SW4) on the Main Board Unit of the BKSU is set to the ON position to enable the battery backup option.
5. Make sure the MDF cables connected to the BKSU are secure and are plugged into the correct position.

Power Up Sequence

The power up sequence involves 1) the proper application of AC power to the system and 2) defaulting the system. A successful power up is assured if installation checklist is followed.

1. Plug the AC power cord of the Key Service Unit into the dedicated 117V AC outlet.
2. Turn the power switch of the KSU to ON.
3. On the MBU, set switch 8 on(SW5) to the OFF position to retain changes to the database.

The system is ready for programming. If problems occur, refer to [Chapter 4, "Maintenance and Troubleshooting."](#)

Table 3-7: Power Supply Tests

Voltage Destination	Voltage Reading	Test Point Location
117V AC	+117V AC, ±10%	Commercial Power Source

4

Maintenance and Troubleshooting

This chapter provides a guideline for isolating and resolving functional problems that may be encountered due to improper use or component failure of the *STARPLUS STS* system. Other failures, such as no dial tone from the central office, must also be considered as an overall troubleshooting procedure.

» » » » » » » »

NOTES

» » » » » » » »

--	--

System Programming and Verification

System operation should be verified as per the programmed customer database once all customer database programming is completed. A hard copy of the customer database can be printed from the system and should be kept on-site and up-to-date for future reference.



System must be initialized before the customer database is programmed.

The **STS** System is a highly-featured digital switch and, as such, feature activation can sometimes be mistaken for improper operation. First, verify all programmable features are enabled for the phone or function in question. Then compare the suspected improper operation with the feature operation description to determine which feature is causing conflict. Be aware that some features can *override* others and take precedence in operational priority. Then make the necessary programming changes in customer database programming to acquire the desired operation.

If feature operation is not the cause of the suspected problem, then general troubleshooting procedures should be employed. Use these basic guidelines to determine the cause of a reported problem:

1. Verify that system programming is correct and that the suspected feature, circuit, or function was enabled in programming.
2. Check the installation cabling/wiring and connectors for cuts, shorts, or loose connections.

By verifying correct operation for each segment of the installation and system, the source of the problem is isolated and can thereby be identified and resolved.

Telephone and Terminal Troubleshooting

This section discusses general functions available for use on the system. It is assumed that basic troubleshooting skills in the identification and resolution of basic problems are already possessed (e.g., static/noise heard on conversation, one phone only; replace worn handset cord).

Keypad Self Test

The *STARPLUS STS* System contains a test mode feature that supports off-line testing of digital keysets and DSS units. The term off-line means that the unit under test is operationally disconnected from the switch during the test operation. Keysets not under test continue to operate in the normal manner. Tests are provided to verify the keypad and DSS LED, LCD, and keyboard button operations.

- The test mode is entered by taking a keypad's handset off hook.
- Press the SPEED button and dial [7#] on the dial pad to disconnect the keypad from the system and bring up the Test Mode Menu on the keypad's LCD. To exit the test mode, place the handset back on hook. This reconnects the keypad to the system.

Test Mode Menu -- The menu allows you to select a test mode by dialing the mode number at the dial pad. You can always return to the main test menu by pressing [##].

```
SELECT 1:LCDLED 2:KEYBTN 3:DSSBTN
```

Keypad LCD/LED Test

This test outputs a series of continuously repeated LCD string messages to LCD lines 1 and 2. The set of strings consists of the letters A through X, a through x, "PICKUP TRUCK SPEED ZONE!", and "***STANDING BACK***".

1st Example - First Message String

```
ABCDEFGHIJKLMNPOQRSTUVWXYZ  
abcdefghijklmnopqrstuvwxyz
```

2nd Example - Second Message String

```
abcdefghijklmnopqrstuvwxyz  
ABCDEFGHIJKLMNPOQRSTUVWXYZ
```

3rd Example - Third Message String

```
"PICKUP TRUCK SPEED ZONE !"  
"*** STANDING BACK ***"
```

4th Example - Fourth Message String

```
"*** STANDING BACK ***"  
"PICKUP TRUCK SPEED ZONE !"
```

Keypad Button Test

1. Press a keypad button to turn on the LED and display an LCD message identifying the button number.



Each time the selected fixed feature button is pressed it sequences through the table of flash rates available. Refer to [Table 4-1: Flash Rates](#).

Table 4-1: Flash Rates

Button	IPM	Type
01	On	Steady
02	30	Flash
03	60	Flash
04	60	Double Wink
05	240	Flash
06	240	Flutter
07	480	Flash
08	480	Flutter
09	15	Flash
10	120	Flash
11	120	Flutter
12	30	Double Flash
13	480	Double Wink
14	480	Double Flash

2. Press the dial pad keys to display an LCD message that indicates which digit was pressed. Depressing the H-T-P switch from one position to another displays one of the following words: H_POS, T_POS, or P_POS.
3. Test LEDs independently of the Keys by pressing the flex LED button.

DSS LED/Button Test

When the DSS test is selected and a DSS test is invoked, all DSS units associated with the keypad are placed in the test mode.



If no DSS unit is associated with the keypad, the keypad display indicates NO DSS. The DSS LED test causes all the LEDs to light steady. All LEDs remain lit steady until a DSS flex button is pressed. Pressing a DSS button turns on the DSS button LED and displays an LCD message on the associated keypad identifying the DSS button number (01 to 48). This button also turns off the previously selected flex LED.



Chapter 4 - Maintenance and Troubleshooting
Conditions

Test mode interrupts the normal operation of a keyset or DSS.

Key Telephones/Terminals

The following actions apply to multi-line key telephones:

Table 4-2: Key Telephones/Terminals

Symptom	Action
No power to keyset	Verify that keyset is connected to correct type of station card.
No handsfree answer-back on intercom	On digital keysets, the mode of intercom answer is programmable.
CO line/station button will not access CO line/station	Check flexible button programming for that button.
Speakerphone does not work	Check station programming for speakerphone enable.
Cannot call another intercom station	Check off hook preference programming.
No Camp On signals or override to phone	Check station programming for override enable.

Single Line Telephones

The following applies to all 2500-type single line telephones connected to the system.

Table 4-3: Single Line Telephone

Symptom	Action
Phone will not dial out	Verify correct SLT type programmed in station identification. Verify line group access programming.
No ringing to phone	Check CO line ringing assignments in programming.
Message waiting lamp does not work	Check station ID assignment in programming.
	Make sure the MSGU is installed on the SLIB.
Cannot call another intercom station	Check off hook preference programming. Put all unused CO lines in a CO line group not currently being used.

DSS/BLF Console

The following applies to DSS/BLF Consoles:

Table 4-4: DSS/BLF Console

Symptom	Action
Buttons on DSS/BLF do not function as labeled	Check station identification assignment in programming for correct DSS map assignment.
Pressing buttons on DSS does not activate keyset	DSS must be assigned to keyset in station ID programming.

CO Line Card Functions

The following applies to LCOB interface cards. Each LCOB contains four Loop Start CO lines.

Table 4-5: CO Line Loop Start Board (LCOB)

Symptom	Action
Loop Start CO lines on the system do not work	Check or change card. Check CO line demarcation.
CO line(s) does not ring	Check CO line ring assignment in programming.
Noise or cross-talk on the line	Check CO line at demarcation for cross-talk. Check with different card at different station.
Telephone side tone is high ...	<input type="checkbox"/> Check LCOB Loop Length programming.

System Functions

The following functions are related to system resources and the common equipment boards controlling them.

Table 4-6: System Functions

Symptom	Action
Basic KSU and MBU	
Complete system failure	Verify that power switch is on, power cord is plugged in. Check power LED on MBU (near transformer).
Any correctly activated feature does not work properly	Check system programming related to specific feature.
Loss of system intercom dial tone and call processing tones	Check off hook preferences, headset mode, and verify on another telephone.
Loss of customer database programming	Verify status of initialization switch, database backup battery connection, battery voltage, and system programming.
Customer database cannot be programmed	Verify that no one else is accessing database programming.
Modem Unit (MODU)	
Cannot access system database programming remotely	Verify modem installation and programming. Check modem baud rate.

Remote Maintenance

General Overview

The Remote Maintenance feature allows authorized personnel to survey system, slot configuration information and programming. This can be done through the optional modem. The commands are entered from a keyboard.

Maintenance Command Format

There are four basic commands available in the Remote Maintenance feature. All commands begin with a single character, followed by a space, another character and an optional digit or digits. All commands are terminated with the <Enter> key.

Maintenance Password

The Maintenance feature, like Programming, is entered via a six-character alphanumeric string. The password prompt is given by pressing <Enter> at the device connected to the RS232-1 port (COM1) of the BKSU or connected to the modem. After the prompt displays, enter the password, then press <Enter>. Proper entry of the password displays the maintenance prompt.

» The Maintenance password is: **config**

Exit Maintenance

The Exit command terminates the current Maintenance feature session.

» The Exit command format is: **maint>x**

```
maint>?
command list:
c      - clear log error trace
d s[nn] - dump system or slot configuration data
        [nn] specifies an optional slot number parameter
        no parameter indicates that the entire system will be
        dumped examples:
                maint>d s      (dumps entire system configuration)
                maint>d s2    (dumps slot 2 configuration, etc.)
d b      (dumps busy device.)
d e      (dumps event trace.)
d p      (dumps pp que error counts.)
r cxxx   (reset coline)
r kxx    (reset cab/slot)
r sxxx   (reset station)
d r      (dumps RCVR configuration.)
d r01    (toggle RCVR 01 stat & dumps configuration)
f p      (flush pp que error counts)
t0..4   - set trace (off,soft start,cold start,soft/cold start,error log
x        - exit maint
?        - help menu
```

Figure 4-1: Maintenance Help Menu

System Configuration

Figure 4-2 is a configuration of the *STARPLUS STS* System and displays what is printed when the installer types **d<space>s** at the `maint>` prompt.

```

maint>d s
  SLOT      CARD   CKTS   SERV STAT   BRD OPTS   FW VER.
-----
   00      DTIB    8      INS         0         00-0
   01      LCI4    4      INS         0         00-0
   02      SLIB    2      INS         0         -0
   03      DTIB    8      OOS         0         -0
   04      DTIB    8      OOS         0         -0
   05      LCI4    4      OOS         0         -0
   08      DTIB    8      OOS         0         -0
   09      DTIB    8      OOS         0         -0
          MBU          INS         Eng. v0.00 P01-FFFF
  
```

Figure 4-2: System Configuration

Column	Indicates the following ...
1	Card slot position
2	Card type of that card slot
3	Card status <ul style="list-style-type: none"> <input type="checkbox"/> OOS status can indicate the entire card is out of service, or a specific station is not installed or installed but not operational. <input type="checkbox"/> INS status can indicate a specific station is installed and operating correctly.
4	Card options
5	Firmware version of card

Station Configuration

Figure 4-3 is a configuration of the **STARPLUS STS** System and displays what is printed when the installer types **d<space>s1** at the **maint>** prompt.

```

maint>d s0
  SLOT      CARD  CKTS  SERV STAT  BRD OPTS  FW VER.
-----
   00      DTIB   8     INS         0         00-0

  STA
  FLEX-FIX-PORT  TYPE      STATUS  LCD  STATE
-----
  100-100-002   STS 24BTN   INS     Y   IDLE
  101-101-003   STS 24BTN   INS     Y   IDLE
  102-102-004   STS 24BTN   INS     Y   IDLE
  103-103-005   STS 24BTN   OOS     Y   ID UNKNOWN
  104-104-006   STS 24BTN   OOS     Y   ID UNKNOWN
  105-105-007   STS 24BTN   OOS     Y   ID UNKNOWN
  106-106-008   STS 24BTN   OOS     Y   ID UNKNOWN
  107-107-009   STS 24BTN   OOS     Y   ID UNKNOWN

```

Figure 4-3: Station Configuration

Column	Indicates the following ...
1	Station Number
2	Station Type (keyset, DSS, SLT) Keyset - ID 0 = Key station DXX 1 = DSS Map 1 DXX 2 = DSS Map 2 SLT - ID 6 = SLT SLT w/Lamp - ID 7 = SLT w/Message Waiting
3	Status <input type="checkbox"/> OOS status can indicate the entire card is out of service; a specific station is not installed; or installed but not operational. <input type="checkbox"/> INS status can indicate a specific station is installed and operating correctly.
4	Whether or not the station has an LCD Display
5	State of the device

CO Line Configuration

Figure 4-4 is a configuration of the STS system and displays what is printed for Slot 5 when the following occurs:

an LCOB is installed in that slot,

-and-

the installer types **d<space>s5** at the `maint>` prompt.

```

maint>d s5
  SLOT      CARD   CKTS   SERV STAT   BRD OPTS   FW VER.
  -----
    05      LCI4    3      OOS         0          -0

  CO-PORT   STATUS      Grp Type   PULSE/DTMF   CO/PBX   STATE
  -----
    5-020   OOS, Bothway  1 2      DTMF         CO      WIDLE
    6-021   OOS, Bothway  1 2      DTMF         CO      WIDLE
    7-022   OOS, Bothway  1 2      DTMF         CO      WIDLE
  
```

Figure 4-4: CO Line Configuration

Column Indicates the following ...

1 CO Line Number

2 Status

OOS status can indicate the entire card is **out of service**.

INS status can indicate a board station is **in-service** and operating correctly.

Incoming = Incoming CO line calls are allowed

Outgoing = Outgoing CO line calls are allowed

Bothway = Both incoming and outgoing CO line calls are allowed

EXAMPLES

Outgoing Enabled indicates the CO line is active in the system.

Outgoing Disabled indicates that the Attendant has disabled the CO line for outgoing access.

3 CO Line Group Number

4 CO Line Type

0 = None

1 = Data

2 = Loop Start

3 = Ground Start

4 = DID

5 = TIE

6 = TIE-DNIS

7 = TIE-ANI

5 Whether CO Line is Pulse or DTMF (programmable option)

6 Whether Line is a CO Line or a PBX Line (programmable option)

7 CO line State

Event Trace Buffer

The Event Trace Buffer is used to store and dump event traces (up to 30) that occur just prior to an **STS** system soft or hard restart. The data can then be reviewed by authorized personnel to aid in system troubleshooting.

The basic format for the system commands are as follows:

Table 4-7: Event Trace Buffer Command

Command	Function
t<space><return>	Displays the current status of the Event Trace Buffer.
t<space>0<return>	Turns the Trace buffer OFF.
t<space>1<return>	Turns the Trace buffer ON to record events prior to a soft system reset.
t<space>2<return>	Turns the Trace buffer ON to record events prior to a hard system restart.
t<space>3<return>	Turns the Trace buffer ON to record events prior to either a soft reset or a hard system restart.
d<space>e<return>	Dumps Trace Events stored from last system reset (soft or hard).
d<space>b<return>	Permits maintenance personnel to determine the busy status of all the busy keysets and CO Lines in the system, including the T1 lines.
r<space>sXXX<return>	Permits a specific station to be reset.
r<space>cXXX<return>	Permits a specific CO Line to be reset.



Press the <ESC> key to abort the Data Dump and return to the maint> prompt.

DTMF Receiver Trace

The CONFIG utility allows technicians to take specific DTMF receivers in/out of service. This is useful for troubleshooting DTMF receiver problems to isolate a specific DTMF receiver that may be faulty.

1. Connect a PC with communication software to I/O port 1 on the MBU.
2. At the ENTER PASSWORD> prompt, type **[config]** and press <Enter>.

Basic Format for Commands

d<space>r<return> - to display the status of all DTMF receivers in the system.

The display shows the receiver number, cabinet location, card slot location, receiver status, and state of the receiver.

Examples

Making a Receiver Busy:

d<space>rXX<return> - (XX is the receiver number to make busy.)

Making a Receiver Available:

d<space>rXX<return> - (XX is the receiver number to make available.)

Remote System Monitor

General Overview

The Remote System Monitor feature provides access to the installed system for diagnostic purposes. These capabilities benefit service personnel enabling them to support the end user. Different levels of access, via password, allows authorized personnel to trace, monitor and upload critical information directly from the **STS** System. This provides a more accurate means of acquiring system information that leads to a quick resolution of problems that may occur. This is all done without interfering with ongoing call processing or normal system operation, and in many cases may be performed without a site visit. The optional 9600 baud modem is used for remote access.

Capabilities allowed and reserved for this high level troubleshooting include the following:

- Monitor Mode
- Enable and Disable Event Trace
- Dump Trace Buffer (upload)

Monitor Password

The Monitor feature, like Maintenance, is entered via a six-character alphanumeric string. The password prompt is accessed by pressing the <Enter> key at the PC connected to the RS232-1 port (COM1) of the BKSU or connected to the modem. After the prompt displays, type the password, then press <Enter>. Proper entry of the password results in the mon> prompt.

» The Maintenance password is: **etrace**



The Remote Monitor feature is intended for use only under the guidance and instruction by authorized personnel from Vodavi Technical Support. Care and caution must be observed when using this feature as permanent damage to the software structure can occur.

Help Menu

A convenient Help Menu is provided by typing [?], then pressing <Enter>. The following screen displays:

```

mon>?
command list:
?      - help menu
a board - board-cmd slot,cmd,data1,data2
b rate  - set baud rate
c [c]   - dump co data
d [a][a] - dump memory
e [s]   - dump prot sta data
f       - flush minor alarm log
g [s]   - dump local sta data
h       - hdlc status report
k       - key-cmd sta,cmd,data1...data17
l       - display minor alarm log
m add   - modify memory
n       - display stack trace
p       - Send Sta Event (Sta Event Data1 Data2)
q       - Send Sta Event (Sta Event Data1 Data2) & exit monitor
s [s]   - dump sta data
t [d]   - set trace key
x       - exit monitor

```

Figure 4-5: Help Menu

Dump Memory Data

Three options allow the memory structure to be dumped for viewing. The options are entered as follows:

- c [c] – Dump CO Line memory structure
- s [s] – Dump Station memory structure
- d [a][a] – Dump a memory address structure

The data obtained from these commands is in hexadecimal format and is used primarily for manufacturer-level support.



Press the <ESC> key to abort the Data Dump and return to the mon> prompt.

Event Trace Mode

The T command enables and disables the *STS* System Trace mode. While the trace mode is enabled events for the trace desired displays on the monitor, printer or PC connected to the *STS* system. To view the current status of the trace mode type [t] and press <Return> at the mon> prompt, the following screen displays:

```

mon>t
Cmd   Messages   Y/N
----  -
B - BOARD EVT -> N
C - COL States -> N
D - Dev PP Cmd -> N
E - Error Msg  -> N
H - H/W States -> N
I - CTI PP Msg -> Y
K - LCD PP Cmd -> N
L - LED PP Cmd -> N
M - MSC States -> N
P - PCM        -> N
Q - Que Evt   -> Y   Trace ALL
S - Stn States -> N

mon>

```

Figure 4-6: Trace Mode Status

- To enable an Event Trace, type **t<space>** (space bar).
- Indicate type of trace desired [d], where d is determined as follows:
 - B Board event trace (traces events associated with PCB)
 - M Miscellaneous State event trace
 - P Pulse Coded Modulation (PCM) traces events associated with voice communications
 - C CO Line (LCOB) States (traces events associated with CO Line activity)
 - S Station (STA) States (traces events associated with Station activity)
 - E Error Messages (traces error messages)
 - Q Queue (QUE) Events (traces queuing events: DTMF receiver, UCD, LCR, etc.)
 - D D= Device Command (traces commands to peripheral devices)
- Enter the specific board, CO line or Station number of the trace desired, or type all when all boards, CO lines or Stations events are desired.
 - 001-028**= CO Line port
 - 100-149**= Station location
 - All = All Boards, CO lines or Stations

4. Press <Enter> to enable the trace. A screen similar to the following displays:

```

mon>t b

Cmd   Messages   Y/N
----   -
B - BOARD EVT   -> Y
C - COL States  -> N
D - Dev PP Cmd  -> N
E - Error Msg   -> N
H - H/W States  -> Y
I - CTI PP Msg  -> N
K - LCD PP Cmd  -> N
L - LED PP Cmd  -> N
M - MSC States  -> N
P - PCM         -> N
Q - Que Evt     -> N
S - Stn States  -> N

mon>

```

Figure 4-7: Enable Event Trace

5. To disable or turn off a particular trace mode, *do not enter* a specific board, CO Line or Station Number (e.g., **t<space>s<return>** to disable station event trace). To have event traces displayed on the screen, exit the MONitor mode by typing **x** at the mon> prompt. After exiting the event(s), the trace begins as shown in [Figure 4-8](#).



Unless instructed by personnel at Vodavi Technical Support, do not leave the trace mode enabled for extended time periods. The system dumps the requested event(s) trace which may use up paper or fill memory buffers on the collecting device. It is recommended that the trace events be disabled (turned off) for all event(s) traces before leaving the system site unless otherwise instructed by Technical Support.

Modify Memory Command

The Modify Memory command is for "engineering use only".



*Using this command can alter or damage the **STS** System operating database which can result in system malfunction. If this occurs, power the system down and re-initialize the database, then completely reprogram the customer programming data.*

Exit the Monitor Mode

The Exit command terminates the current Monitor enable/disable session. If Event(s) Trace was or is still enabled, event records display only after exiting the MONitor mode.

» The Exit command format is: `mon> x`

```

mon>x
DATE: 02/19/XX TIME: 10:46:33
exiting monitor...

Sta 100: State= IDLE, Evt= Dial Pad (26), Data=1
Sta 100: State= DIALING, Evt= Dial Pad Release (31), Data=1
Sta 100: State= DIALING, Evt= Dial Pad (26), Data=10
Sta 100: State= DIALING, Evt= Dial Pad Release (31), Data=10
Sta 100: State= DIALING, Evt= Dial Pad (26), Data=2
Sta 100: State= DIALING, Evt= DSS (60), Data=2
Sta 100: State= WAIT_DSS_SZ_RSP, Evt= Seize Nak (15), Data=1
Sta 100: State= MISC_TONE, Evt= Dial Pad Release (31), Data=2
Sta 100: State= MISC_TONE, Evt= Key Data (27), Data=52
Sta 100: State= MISC_TONE, Evt= Mon Key (145), Data=-1
Sta 100: State= MISC_TONE, Evt= On Hook (17), Data=0
Sta 100: State= IDLE, Evt= Seize (14), Data=10
Sta 100: State= RINGING, Evt= Aux (34), Data=0
Sta 100: State= RINGING, Evt= Ring Update T/O (151), Data=0
Sta 100: State= RINGING, Evt= Key Data (27), Data=52
Sta 100: State= RINGING, Evt= Mon Key (145), Data=-1
Sta 100: State= TALK, Evt= Ring Update T/O (151), Data=0
Sta 100: State= TALK, Evt= Key Data (27), Data=52
Sta 100: State= TALK, Evt= Mon Key (145), Data=-1
Sta 100: State= TALK, Evt= On Hook (17), Data=0

```

Figure 4-8: Event Trace

SMDR

The SMDR feature provides detailed records of all outgoing and/or incoming, long distance only or all calls. The SMDR Qualification Timer determines the time needed to determine a valid SMDR call for reporting purposes. By default, this timer is set to 30 seconds and is variable from 00-60 seconds in one-second increments. This feature is enabled or disabled in system programming. By default, SMDR is disabled and set to record long distance calls only.

A printout format of 80 characters maximum or 30 characters maximum may be selected in system programming. The standard format is 80 characters per line. A 30-character format generates three lines per message.

If the SMDR feature is enabled, the system starts collecting information about the call as soon as it starts and terminates when the call ends. If the call was longer than 30 seconds, the following information is printed:

80 character format - Outbound Call to a Dialed Number:							
1	2	3	4	5	6	7	8
1234567890123456789012345678901234567890123456789012345678901234567890							
AAAA	BBB	HH:MM:SS	HH:MM	MM/DD/YY	HCCCCCCCCCCCCCCCCCCCCC	GGGGGGGGGGGG	(CR) (LF)
STA	CO	TOTAL	START	DATE	DIALED		
100	001	00:00:38	13:57	01/15/01	O2956006		
80 character format - Outbound Call to an Extension:							
1	2	3	4	5	6	7	8
1234567890123456789012345678901234567890123456789012345678901234567890							
AAAA	BBB	HH:MM:SS	HH:MM	MM/DD/YY	HCCCCCCCCCCCCCCCCCCCCC	GGGGGGGGGGGG	(CR) (LF)
STA	CO	TOTAL	START	DATE	DIALED		
100	031	00:00:08	13:58	01/15/01	O2108		**
**CALL TO HOWARD							
80 character format - Outbound Call to an Extension:							
1	2	3	4	5	6	7	8
1234567890123456789012345678901234567890123456789012345678901234567890							
AAAA	BBB	HH:MM:SS	HH:MM	MM/DD/YY	HCCCCCCCCCCCCCCCCCCCCC	GGGGGGGGGGGG	(CR) (LF)
STA	CO	TOTAL	START	DATE	DIALED		
102	031	00:00:11	13:59	01/15/01	O2101		**
**CALL TO STA2101							
80 character format - Inbound Call from an Extension:							
1	2	3	4	5	6	7	8
1234567890123456789012345678901234567890123456789012345678901234567890							
AAAA	BBB	HH:MM:SS	HH:MM	MM/DD/YY	HCCCCCCCCCCCCCCCCCCCCC	GGGGGGGGGGGG	(CR) (LF)
STA	CO	TOTAL	START	DATE	DIALED		
100	031	00:00:03	13:59	01/15/01	I2108		**
**HOWARD CALLING							
- continued on next page -							
80 character format - Inbound Call to a Station From CO Line 1 with No Caller ID:							
1	2	3	4	5	6	7	8
1234567890123456789012345678901234567890123456789012345678901234567890							
AAAA	BBB	HH:MM:SS	HH:MM	MM/DD/YY	HCCCCCCCCCCCCCCCCCCCCC	GGGGGGGGGGGG	(CR) (LF)
STA	CO	TOTAL	START	DATE	DIALED		
100	001	00:00:04	13:59	01/15/01	I		
LEGEND:							
- AAAA = Station originator or Trunk on DISA and Off-Net (CO Line) calls.							
- BBB = Outside line number							
- HH:MM:SS = Duration of call in Hours, Minutes and Seconds							
- HH:MM = Time of day (start time) in Hours and Minutes							
- MM/DD/YY = Date of Call							
- H = Indicates call type:							
"I" = Incoming*							
"O" = Outgoing							
"T" = Transferred*							
"U" = Unanswered calls for ICLID SMDR call records							
- CC....CC = Number dialed							
- GG....GG = Last Account code entered (optional)							
- (CR) = Carriage return							
- (LF) = Line Feed							

Figure 4-9: SMDR Printout

Index

A

AC Power Plug 3-8
Add-On Boards 1-8
ANI 3-18
ANI/DNIS 3-18
Audible Signals 2-6
Automatic Number Identification (ANI) 3-18

B

Backboard Installation 3-4
Basic Cabinet 1-4
Basic Key Set Unit 1-4
Basic System Configuration 1-4
Battery Backup Duration 3-7
Battery Backup Unit Installation 3-7
BKSU 1-4
BKSU/MBU Assembly 3-11
Board Capacity 3-9
Built-in Power Supply 1-6, 3-7

C

Cable Connections 3-8
Card Slot Configuration 3-9
Card Slot Positions 3-10
CIDU 3-15
CIDU (for Built-In LCOB) 3-12
CO Champ Connectors 3-26
CO Interface Boards 1-7
CO Line Card Functions 4-7
CO/Station Wiring 3-24
Configuration Tables 2-3

D

Dialed Number Identification Service (DNIS) 3-18
Dialing Specifications 2-7
Digital Keyset - Wall Mounting 3-28
Digital Keyset & Terminal Wiring 3-27
Digital Telephone Interface Board
 8 port - built-in 3-12
 8 port - optional 1-6
Dimensions and Weights 2-8
DNIS 3-18

DSS LED/Button Test 4-5
DTIB 3-12
 8 port - built-in 3-12
 8 port - optional 1-6
DTMF Tone Detection Units 3-20
DTRU4 3-20
Dump Memory Data 4-15

E

EKSU 1-6
Electrical Specifications 2-8
Environmental Specifications 2-8
Expansion Board Installation 3-14
Expansion Cabinet 1-6
Expansion Key Service Unit 1-6
Extension Boards 1-6

G

Grounding 3-6

H

Headset Installation 3-29
Help Menu 4-15

I

Installing a Headset 3-29

K

Key Service Unit 1-4
Keyset
 Button Test 4-5
 LCD/LED Test 4-4
 Self Test 4-4
Keyset - Wall Mounting 3-28
Keyset/Headset Installation 3-28
KSU
 AC Power Plug 3-8
 Grounding 3-6
 Mounting 3-5

L

- LCOB (4 CO Lines w/Caller ID)
 - Built-In LCOB 3-12
 - Optional LCOB 1-7, 3-14
- Lightning Protection 3-8
- Loop Start CO Interface Board (w/Caller ID)
 - Built-In LCOB 3-12
 - Optional LCOB 1-7, 3-14

M

- Main Board Unit (MBU) 1-5
- Maintenance Password 4-9
- Message Wait Unit (MSGU48) 1-8, 3-15
- Miscellaneous Specifications 2-7
- Modem Unit (MODU) 1-8
- Modem Unit (MODU) Installation 3-21
- MODU 1-8, 3-21
- Monitor Password 4-15
- Mounting the KSUs 3-5
- MSGU48 1-8, 3-15

P

- Part Numbers 2-9
- PCB Handling and General Installation 3-9
- Phase Lock Loop Unit (PLL) 1-8, 3-19
- PLL 1-8, 3-19
- Power Line Surge Protection 3-8
- Power Supply (Built-In) 1-6, 3-7
- Power Up Sequence 3-30

R

- Remote Maintenance 4-9
- Remote System Monitor 4-14

S

- Single Line Adapter 3-23
- Single Line Telephone Interface Board
 - 2 port with built-in msg wait 1-5, 3-13
 - 4 port optional SLIB4 1-7, 3-15
- Single Line Telephone Wiring 3-27
- Site Preparation 3-3
- SLIB2 w/built-in msg wait 1-5, 3-13
- SLIB4 (4 port) 1-7, 3-15
- SMDR 4-18
- Station Champ Connectors 3-25

- Station/CO Wiring 3-24
- Surge Protection 3-8
- System
 - Backup Duration 3-7
 - Capacities 2-3
 - Checkout 3-29
 - Commands
 - DTMF Receiver Trace 4-14
 - Event Trace Buffer 4-13
 - Event Trace Mode 4-16
 - Exit Maintenance 4-9
 - Exit Monitor Mode 4-18
 - Modify Memory 4-17
 - Functions 4-8
 - Part Numbers 2-9
 - Programming and Verification 4-3

T

- T1 Interface Board (T1IB) 1-7, 3-16
- T1IB 1-7, 3-16
- Telco to T1IB Interconnect Diagram 3-19
- Telephone and Terminal (Troubleshooting) 4-3
- Tone Specifications 2-6

V

- Visual Signals
 - CO Line Buttons 2-4
 - DSS/BLF Buttons 2-5
 - Feature/Function Buttons 2-5
- Visual Specifications 2-4
 - CO Line Buttons 2-4
 - DSS/BLF Buttons 2-5
 - Feature/Function Buttons 2-5

W

- Wall Mounting the Digital Keypad 3-28
- Wiring
 - Digital Keypad & Terminal 3-27
 - Single Line Telephone 3-27