

**LANDMARK**  
**DIGITAL KEY SYSTEM**  
**DKS 308XL**

Southwestern Bell Telecom

**SYSTEM ADMINISTRATOR**  
**MANUAL**

---

# IMPORTANT SAFETY INSTRUCTIONS

BEFORE USING YOUR TELEPHONE EQUIPMENT, BASIC SAFETY PRECAUTIONS SHOULD ALWAYS BE FOLLOWED TO REDUCE THE RISK OF FIRE, ELECTRIC SHOCK AND INJURY TO PERSONS, INCLUDING THE FOLLOWING:

1. Read 2nd understand all instructions,
2. Follow all warnings and instructions marked on the product.
3. Unplug this product from the wall telephone jack 2nd power outlet before cleaning, Do not use liquid cleaners or aerosol cleaners. Use a damp cloth for cleaning.
4. Do not use this product near water, for example, near a bath tub, wash bowl, kitchen sink, or laundry tub, in 2 wet basement, or near a swimming pool.
5. Do not place this product on an unstable cart, stand, or table, The product may fall, causing serious damage to the product.
6. Slots or openings in the cabinet and the back and bottom are provided for ventilation, to protect it from overheating. These openings must not be blocked or covered. The openings should never be blocked by placing the product on a bed, or other similar surface. This product should never be placed near or over 2 radiator or heat register.
7. This product should be operated only from the type of power source indicated on the marking label. If you are not sure of the type of power supply to your home, consult your dealer or local power company.
8. Do not allow anything to rest on the power cord. Do not locate this product where the cord will be abused by persons walking on it.
9. Do not overload wall outlets 2nd extension cords as this can result in the risk of fire or electric shock.
10. Never push objects of any kind into this product through cabinet slots as they may touch dangerous voltage points or short out parts that could result in the risk of fire or electric shock. Never spill liquid of any kind on the product.
11. To reduce the risk of electric shock, do not disassemble this product, but take it to a qualified serviceman when some service or repair work is required. Opening or removing covers may expose you to dangerous voltages or other risks. Incorrect reassembly can cause electric shock when the appliance is subsequently used.
12. Unplug this product from the wall outlet and refer servicing to qualified service personnel under the following conditions:
  - a. When the power supply cord or plug is damaged or frayed.
  - b. If liquid has been spilled into the product.
  - c. If the product has been exposed to rain or water,
  - d. If the product does not operate normally following the operating instructions. Adjust only those controls that are covered by the operating instructions because improper adjustment of other controls may result in damage and will often require extensive work by 2 qualified technician to restore the product to normal operation.
  - e. If the product has been dropped or the cabinet has been damaged.
  - f. If the product exhibits 2 distinct change in performance:.
13. Avoid using a telephone (other than a cordless type) during an electrical storm, There may be a remote risk of electric shock from lightning.
14. Do not use the telephone to report a gas leak in the vicinity of the leak.
15. Do not attach the Power Cord to building surfaces.

---

# **IMPORTANT SAFETY INSTRUCTIONS**

---

## **SAFETY INSTRUCTIONS FOR BATTERIES**

**TO REDUCE THE RISK OF FIRE OR INJURY TO PERSONS, READ AND FOLLOW THESE INSTRUCTIONS:**

1. Use only the size and type of batteries mentioned in the Installation Manual,
2. Do not dispose of the batteries in a fire. The cells may explode. Check with local codes for possible special disposal instructions.
3. Do not open or mutilate the batteries. Released electrolyte is corrosive and may cause damage to the eyes or skin. It may be toxic if swallowed.
4. Exercise care in handling batteries in order not to short the battery with conducting materials such as rings, bracelets, and keys. The battery or conductor may overheat and cause burns.
5. Charge the battery(ies) provided with or identified for use with this product only in accordance with the instructions and limitations specified in this manual,
6. Observe proper polarity orientation between the battery(ies) and battery charger.
7. Do not mix old and new batteries in this product.
8. Do not mix batteries of different sizes or from different manufacturers in this product,

---

## **TELEPHONE LINE INSTALLATION**

1. Never install telephone jacks during a lightning storm,
2. Never install telephone jacks in wet locations unless the jack is specifically designed for wet locations.
3. Never touch uninsulated telephone wires or terminals unless the telephone line has been disconnected the network interface.
4. Use caution when installing or modifying telephone lines,

**SAVE THESE INSTRUCTIONS**

---

# **IMPORTANT FCC REGULATIONS**

---

## **FCC WANTS YOU TO KNOW**

This equipment complies with Part 68 of the FCC rules. The model label located on this unit contains, among other information, the FCC Registration Number and Ringer Equivalence Number (REN) for this equipment. You must, upon request, provide this information to your telephone company.

The REN is useful to determine the quantity of devices you may connect to your telephone line and still have all of those devices ring when your telephone number is called. In most, but not all areas, the sum of the REN's of all devices connected to one line should not exceed five (5.0). To be certain of the number of devices you may connect to your line, as determined by the REN, you should contact your local telephone company to determine the maximum REN for your calling area.

If your telephone equipment causes harm to the telephone network, the Telephone Company may discontinue your service temporarily. If possible, they will notify you in advance. But if advance notice is not practical, you will be notified as soon as possible. You will be informed in advance to give you an opportunity to maintain uninterrupted telephone service.

If you experience trouble with this telephone equipment, the telephone company may ask that you disconnect this equipment from the network until the problem has been corrected or until you are sure that the equipment is not malfunctioning.

This equipment may not be used on coin service provided by the telephone company. Connection to party lines is subject to state tariffs.

---

## **RADIO FREQUENCY INTERFERENCE**

### **WARNING:**

This equipment generates, uses and can radiate radio frequency energy and if not installed in accordance with the Installation Manual and not used in accordance with the operations manuals included with this unit and any extensions of it, may cause interference to radio communications. It has been tested and found to comply with the limits for a Class A computing device pursuant to Subpart J of Part 15 of FCC Rules, which are designed to provide reasonable protection against such interference when operated in a commercial environment. Operation of this equipment in a residential area is likely to cause interference in which case the user at his own expense will be required to take whatever measures may be required to correct the interference.

---

# TABLE OF CONTENTS

## GENERAL DESCRIPTION

### SECTION 1

INTRODUCTION	1
A V A I L A B L E C O M P O N E N T S	2
CONFIGURATION	3
PICTORIAL PROFESSIONAL KEYSSET	4
PICTORIAL ASSOCIATE KEYSSET	5
PICTORIAL ASSOCIATE PLUS KEYSSET	6

## FEATURES

### SECTION 2

INTRODUCTION TO FEATURES	1
GENERAL RULES OF OPERATION	2
LIST OF FEATURES	4
FEATURES	5

## SYSTEM PROGRAMMING

### SECTION 3

TABLE OF CONTENTS	1
INTRODUCTION	4
GENERAL PROGRAMMING PROCEDURES	4
SOFT KEY FUNCTIONS	6
DATABASE PROGRAMMING TREE	7
DATABASE PROGRAMMING	16
S E T C A T E G O R Y	17
LINE CATEGORY	27
CALL HANDLING CATEGORY	34
RESOURCE CATEGORY	47
RESTRICTION CATEGORY	69
PERIPHERAL CATEGORY	86

## REMOTE SYSTEM PROGRAMMING

### SECTION 4

TABLE OF CONTENTS	1
INTRODUCTION	3
GENERAL INFORMATION	4
DATABASE PROGRAMMING	13
DATABASE COMMUNICATION TO KSU	51

## TROUBLESHOOTING

### SECTION 5

GENERAL	1
LANDMARK HELPLINE	4
HARDWARE FAULT LOCATION	2
FAULT ELIMINATION PROCEDURES	3

---

# TABLE OF CONTENTS

---

## APPENDIX A

SECTION

### SYSTEM PARAMETER REFERENCE

A.1 CADENCES	
A.2 SYSTEM RESOURCE CAPACITY	.....
A.3 TIME AND COUNT PARAMETER VALUES (Fixed or Programmable)	.....
A.4 COUNT PARAMETER VALUES (Fixed or Maximum)	.....
A.5 FACILITY INTERFACE AND SERVICE ORDER CODES	.....

---

## APPENDIX B

SECTION

### FEATURE OPERATION SUMMARY

B.1 SUMMARY OF PROFESSIONAL KEYSET FEATURE OPERATION AND PROGRAMMING	
B.2 SUMMARY OF ASSOCIATE KEYSET FEATURE OPERATION AND PROGRAMMING	..
B.3 SUMMARY OF SINGLE LINE TELEPHONE FEATURE OPERATION AND PROGRAMMING	
B.4 SYSTEM PROGRAMMING CATEGORIES	.....
B.5 SYSTEM PROGRAMMING SUB-CATEGORIES	.....

---

## PROGRAMMING RECORDS

SECTION

# *GENERAL DESCRIPTION*



A to Z KELLATRONICS, Inc.

████████████████████ Tel: 800.766.3425  
email: [info@kellatronics.com](mailto:info@kellatronics.com) Fax: 818.773.8899

---

# GENERAL DESCRIPTION .

## INTRODUCTION

The DKS 308XL is an advanced Digital Key System (DKS)/PBX for up to 16 *extensions* and 6 Central Office (C.O.) lines. The system can be used as a key system, an operator controlled system (attendant), a subsystem of another PBX or a combination of all three,

The Professional keysets have a two-line, dot matrix LCD display that shows the user a wealth of information during use. A system administrator with the proper password can also use the LCD display for system programming instructions.

This system can provide Music on Hold, Background Music, External Paging, an External (loud) Bell, Station Message Detail Recording (SMDR) and Remote Programming Capability by coordinating your system with other appropriate equipment.

---

## GENERAL DESCRIPTION

---

### AVAILABLE COMPONENTS

- DKS 308XL** - KEY SYSTEM UNIT FOR 3 C.O. LINES AND 8 STATIONS. CAN BE EXPANDED BY USING THE DKS 616 EXPANSION BOARD.
- DKS 616** - KSU EXPANSION BOARD FOR ADDING 3 C.O. LINES AND 8 STATIONS.
- DKS 825** - ASSOCIATE KEYSSET (STATION)
- DKS 830** - ASSOCIATE PLUS KEYSSET (STATION)
- DKS 925** - PROFESSIONAL KEYSSET (STATION) WITH DISPLAY
- DKS 930** - PROFESSIONAL KEYSSET (STATION) WITH DISPLAY
- DKS 935** - PROFESSIONAL PLUS KEYSSET (STATION) WITH DATA PORT AND DISPLAY
- DKS 940** - DSS/BLF CONSOLE (ATTENDANT CONSOLE)
- DKS 40** - SMALL POWER SUPPLY FOR 3 LINES AND 8 STATIONS (DKS 308XL)
- DKS 45** - LARGE POWER SUPPLY FOR 6 LINES AND 16 STATIONS (DKS 308XL PLUS DKS 616)
- DKS 50** - ANALOG ADAPTER FOR, CONNECTING 2 ANALOG TELEPHONES/TELFAX/MODEM
- DKS 55** - OPTION BOARD FOR BACKGROUND MUSIC, MUSIC ON HOLD, EXTERNAL PAGING, EXTERNAL BELL, CALL INFORMATION LOGGING, AND REMOTE PROGRAMMING

### OPTIONAL EQUIPMENT FOR THIS SYSTEM:

- DKS 50 Analog Adapter** allows the connection of two tone dialing analog telephones in place of a digit station. A telfax machine and/or a modem can be connected instead of one or both analog telephones.
- DKS 55 Option Board**, with appropriate customer supplied equipment, adds Music On Hold, Background Music, External Paging, and external Loud Bell, Call Information Logging? and Remote Programming capability.
- DKS 940 DSS/BLF (Direct Station Select/Busy Lamp Field) Console** provides LED indicators for the status of all lines and stations.

---

### CONFIGURATION

#### **DKS 308XL** **3 C.O. Lines, 8 Stations**

consisting of:

- one motherboard
- one DKS 616 board
- small power supply (DKS 40)
- up to eight (8) stations  
DKS 825, 830, 925, 930, or 935

#### **DKS 308XL with DKS 616 Expansion Board** **6 C.O. Lines, 16 Stations**

consisting of:

- one complete DKS 308XL KSU
- one additional DKS 616 Board
- large power supply (DKS 45)
- up to sixteen (16) stations  
DKS 835, 835, 925, 930, or 935

# GENERAL DESCRIPTION

## CONFIGURATION, cont'd

### DKS 308XL KSU CONNECTIONS

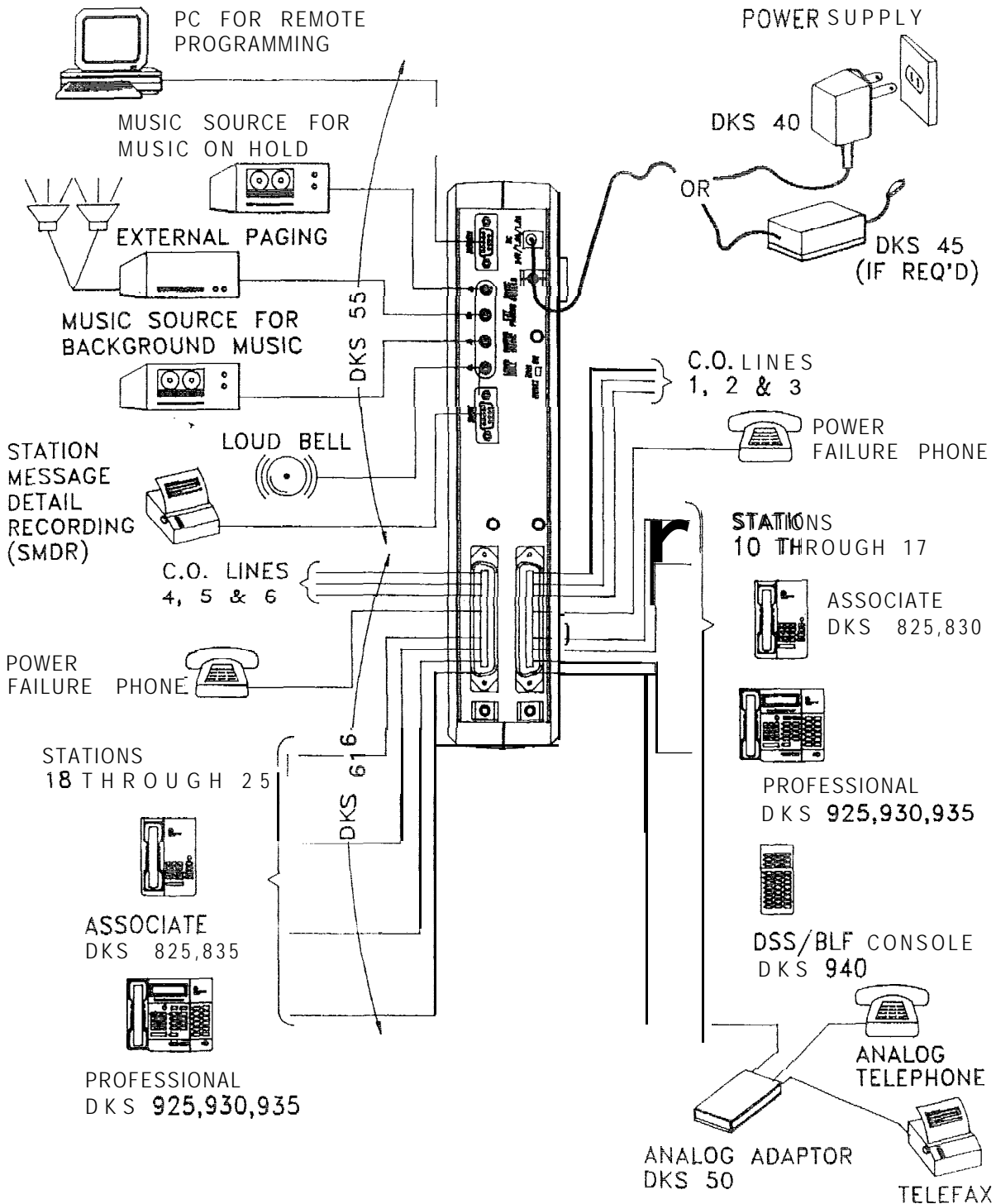

# GENERAL DESCRIPTION

## PICTORIAL OF PROFESSIONAL KEYSET (DKS 925, 930, 935)

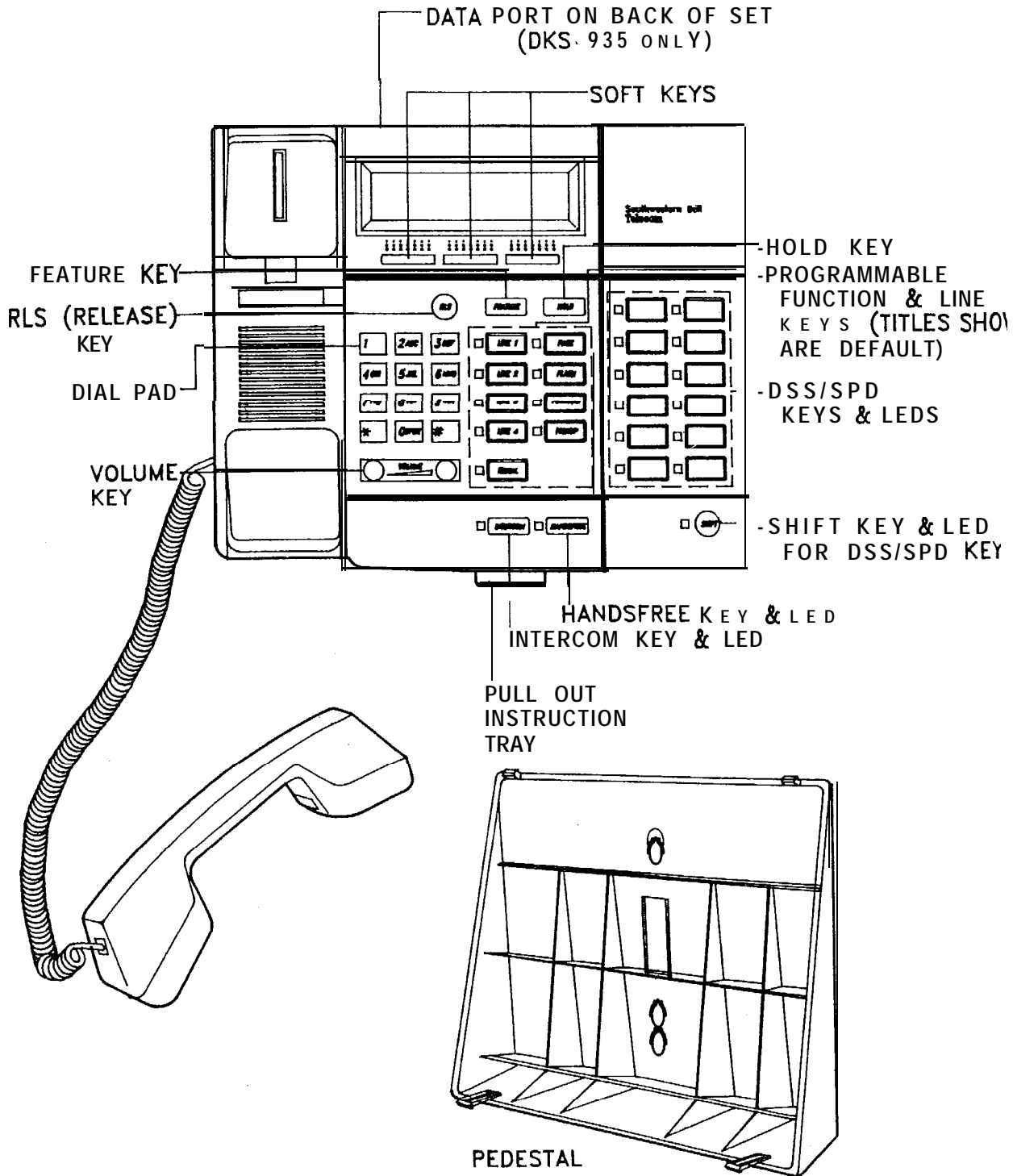

# GENERAL DESCRIPTION

## PICTORIAL OF ASSOCIATE KEYSET (DKS 825)

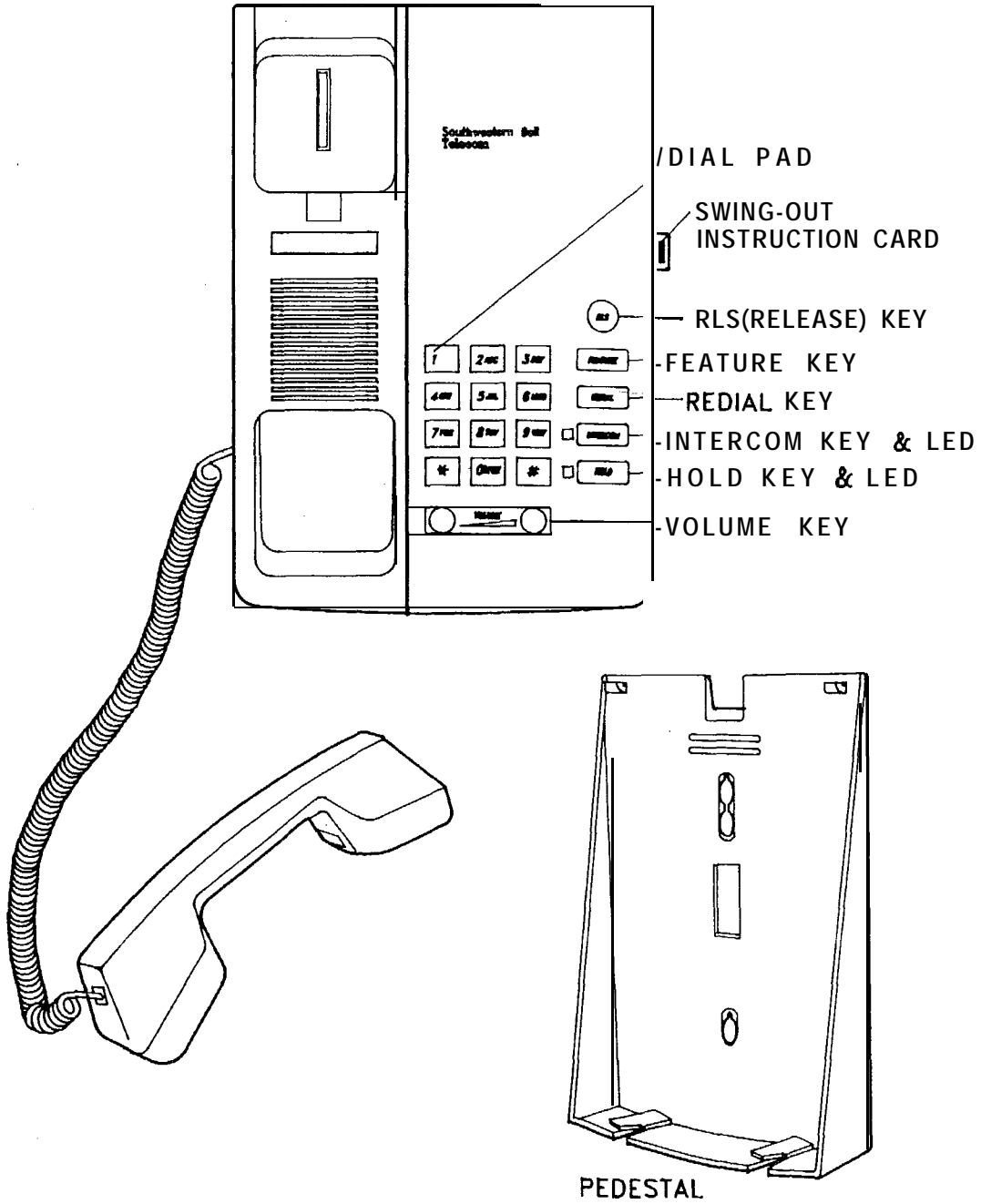

# GENERAL DESCRIPTION

## PICTORIAL OF ASSOCIATE PLUS KEYSET (DKS 830)

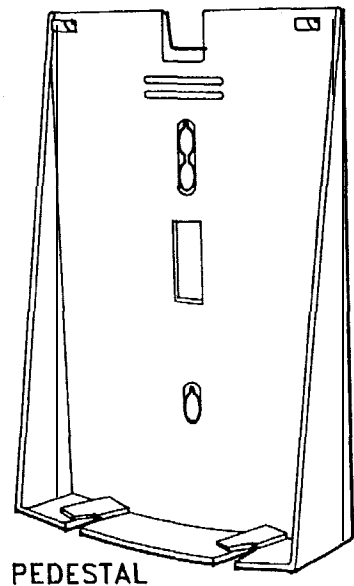
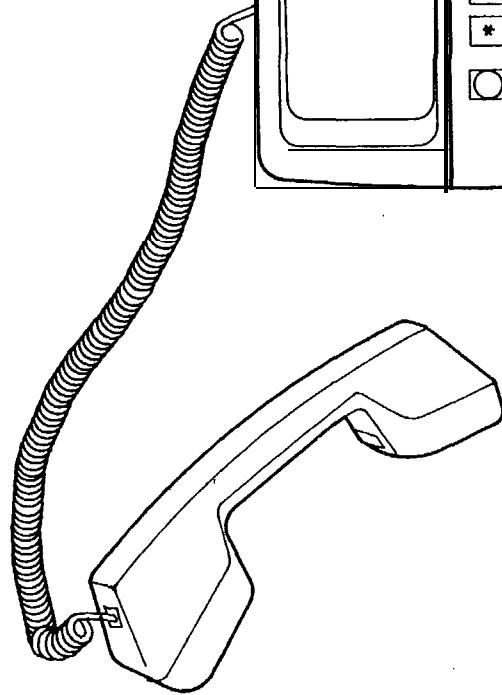
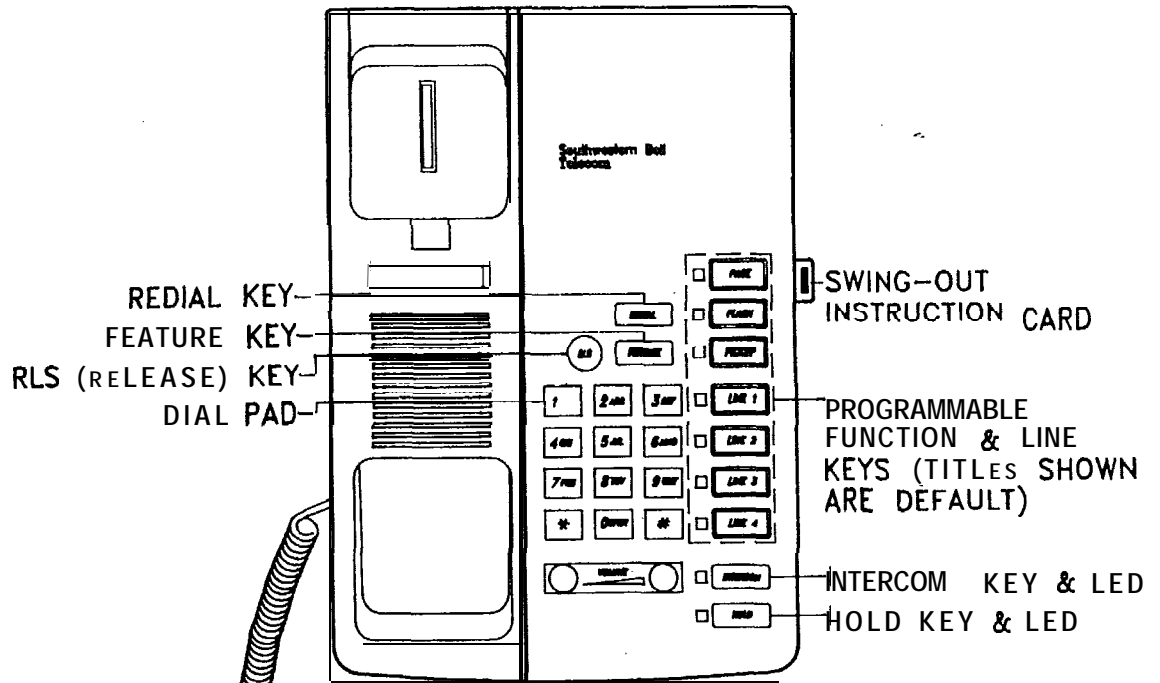

# *FEATURES*



A to Z KELLATRONICS, Inc.

██████████ Tel: 800.766.3425  
email: [info@kellatronics.com](mailto:info@kellatronics.com) Fax: 818.773.8899

# FEATURES

## DATA CALL (DKS 935 ONLY)

The DKS 935 Serial data port is a basic tool for establishing two way data communication over the Landmark system wiring, without the need for separate, dedicated network wires. This link operates via the RS232 port on the DKS 935.

The serial port configuration can be useful primarily for custom applications (such as a customer-designed e-mail network), or as a simple method for sharing a serial printer, or other applications where the flow control between the DTE and the DCE devices is not important.

## OPERATION

Professional Pius **keyset** with Data Port (DKS 935) only:

Press: DATA key.

Enter: the STATION NUMBER of the destination keyset.

To answer the Data Call (called party),

Press: DATA key.

To reject a Data Call (called party),

Press: REJECT soft key.

Either party may end the call:

Press: DATA key.

## PROGRAMMING

You may choose to program Auto Answer for Data Calls. When a Data Call request comes to your station, you will not have to press any key to answer. The connection will be made automatically.

To Auto Answer Data Calls:

Press: F ■ 9 ■ 9

To cancel Auto Answer:

Press: F ■ \* ■ 9 ■ 9

To program a feature key as a DATA key, see *FEATURE KEY PROGRAMMING*.

## SAMPLE SET-UP

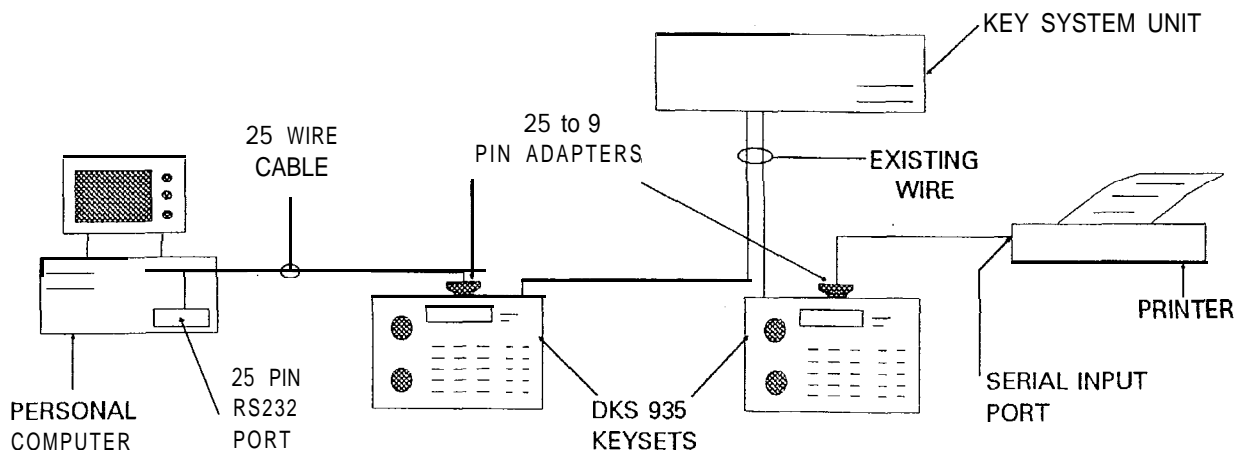

---

# FEATURES

---

## GENERAL RULES OF OPERATION

1. **SOFT** keys perform the function shown above them on the second line of the LCD display. If no function is shown at a particular time, the key will not operate.
2. Most set features can be accessed by pressing the **FEATURE** key, then a one- or two-digit access code. For example, Feature 1 accesses the Speed Dial feature. Station settings (such as whether or not background music plays from the station's speaker) may also be accessed with the Feature key. For a list of set features and codes, see Feature Access Codes, p. 28.
3. The system settings (for example, line configurations, toll restrictions, etc.) are changed through system programming. System programming may be done from a Professional station, with the correct password (see System Programming, Section 3), or through a personal computer connected to the modem port.
4. A description of some common soft and hard key functions relating to station and system programming follows. There are other soft key functions that will appear when using features that are not in the following list. Their operation will be described in the appropriate chapter of the FEATURES section.

**BKSP** (backspace) soft key • when entering digits or letters, pressing the BKSP soft key erases the last character entered, moving the cursor back one spot so the user may re-enter the character.

**SAVE** soft key • after new information is entered, the user presses the SAVE soft key to confirm and store it.

**CHG** (change) soft key •

1. Clears the contents of the current programming item to allow a new entry.
2. Replaces a programming option with the next one. For example, it toggles between 'YES' and 'NO' or cycles through several displayed messages to allow the user to select one.

**NEXT** soft key - displays the next programming item in a category, or the next category if the current item is the last one in such a category.

**BACK** soft key • displays the previous programming item in a category, or the previous category if the current item is the first one in such a category.

**SHOW** soft key • displays the attributes of the feature item shown.

**SHIFT** hard key (EXIT) • pressing SHIFT during programming will abandon the current feature programming item and category, and go back to the next highest category.

**RLS** (release) hard key • abandons station programming. Also abandons call-making and conversations.

---

# FEATURES

---

## GENERAL *RULES OF OPERATION*, cont'd

### 5. Description of other key functions:

**HOLD** key ▪ places an Intercom, Line, or Conference call on hold. Also used when transferring a call.

**FEATURE** key ▪ using this key and an access code activates certain features.

**VOLUME** key ▪ used to independently set listening levels for ringing, handset, speakerphone, and background music. Also adjusts the display contrast.

**PROGRAMMABLE FEATURE** keys ▪ can be programmed to perform a certain function that the user requires.

**HANDSFREE** key ▪ allows you to talk without using the handset during Intercom and Line calls.

**INTERCOM** key ▪ access an intercom link making an internal call or answering an incoming/l-hold intercom call.

**LINE** key ▪ pressing will access an outside line to make a call or answer a held external call.

**SOFT** key ▪ enables feature operation without using an access code, allowing for easy system programming.

**SHIFT** key ▪ is also used to switch from one level of speed dial numbers to the next level and from one level of DSS numbers to the next.

**DSS/SPD** (Direct Station Select/Speed Dial) key ▪ press one of the keys to make an intercom call or to make a speed dialing line call. See **DSS/SPD Key Priority**, page 24.

---

# FEATURES

## DELAYED RING

Delayed Ring is a method of making unanswered incoming C.O. line calls ring, after a programmed delay, at different stations or hunt groups. This allows unanswered line calls to ring at a Voice Mail or Automated Attendant port, at another station, or at a different hunt group.

Two Delayed Ring destinations may be programmed for each line. When the delay time passes without the call being answered by any of the stations with ring assignment for that line, the call will begin to ring at Destination One (station or hunt group). If there is no answer at the first destination after another delay period, the call will ring at Destination Two.

If the destination is a Voice Mail port or a Hunt Group, the system will send a "Reason" and "Originator" DTMF header to the port when the call is answered, if so programmed. The Reason is the "Initial Call" header and the Originator is the line identifier (mailbox number) programmed for the line. For each line, the Reason and Originator headers may be individually programmed to be sent or not.

### PROGRAMMING

To program Destination One and Destination Two for a C.O. line, set the delay time for a line, assign a mailbox number (Originator header) to the line, or select whether "Reason" and "Originator" headers should be sent to voice mail ports for an initial line call,

see System Programming - Line/ Delayed Ring (5.2.8)

To assign a DTMF code to the "Initial Call" Voice Mail header,

see System Programming - Peripheral/ Voice Mail (56.5)

- NOTES:
1. Stations with 'Ring Assignment' set to 'Y' will ring on an incoming call until the delay time has expired. They will then stop ringing and 'Destination One' will start to ring. After a second delay (equal in time to the first), 'Destination Two' will start to ring and 'Destination One' will stop.
  2. If there is no answer, the final destination will continue to ring until the incoming ring signal ceases.
  3. The DTMF headers for 'Reason' and 'Originator' initial calls are programmed in different sections in System Programming (see PROGRAMMING, above). The Initial Call 'Reason' header is the same for all lines, but the 'Originator' header is programmed separately for each line.
  4. The selection of whether or not to send 'Reason' and 'Originator' headers for Delayed Ring calls is made separately for each line (see PROGRAMMING, above).
  5. Delayed Ring is disabled if any of the following are true:
    - a. Delayed Ring is set to 'NONE'.
    - b. First and Second destinations are set to 'NONE'.
    - c. A Hunt Group is a destination, but there are no member stations assigned to the Hunt Group.

- DEFAULT:
1. Delayed Ring time is 'None' for all lines (no Delayed Ring).
  2. Destinations One and Two are 'None' for all lines.
  3. 'Reason' and 'Originator' headers are not sent for any lines.
  4. Mailbox number is 'Empty' for each line.
  5. Initial Call header is 'Empty'.

---

# FEATURES

## DIALING TYPE SELECTION

Dialing on outside lines may be either in Pulse mode or DTMF (Dual Tone Multi-Frequency).

### PROGRAMMING

See System Programming - Line/ Dialing Type Selection (5.22).

**DEFAULT:** DTMF

## DIALING INTERCOM

All stations may call each other by dialing 2-digit codes.

### OPERATION

#### **Professional keyset:**

Handset Call:

Lift handset.

If your auto-line selection is NOT set to Intercom, then

Press **INTERCOM** key.

Enter Z-digit station number you are calling, or press the DSS key for that station.

Handsfree Call:

Press: **INTERCOM** key.

Or,

If your auto-line select is set to Intercom,

Press: **HANDSFREE** key.

Enter: 2-digit station number you are calling, or press the DSS key for that station.

The called party may answer by lifting the handset or pressing the **HANDSFREE** key,

#### **Associate keyset:**

Lift handset.

If your auto-line select is NOT set to Intercom,

Press: **INTERCOM** key.

Enter: 2-digit station number you are calling.

The called party may answer by lifting the handset.

- NOTES:**
1. To make a Voice Call to any station, press '\*' after dialing. Your voice will immediately be heard through the called set's speaker. If the called set is a Professional, the party may reply by speaking, as in a speakerphone call. If the called set is an Associate, the party may lift the handset to reply.
  2. A station may be programmed to treat all received Intercom calls as Voice Calls. See *VOICE CALL*.

---

# FEATURES

---

## ALARM CLOCK, cont'd

To cancel,  
Press: F • \* • 9 • 2

### Associate keyset:

To set up the alarm  
Press: F • 9 • 2 • HH • MM

To cancel the alarm,  
Press: F • \* • 9 • 2

- NOTES:**
1. The station alarm clock will beep even if the user is on a call.
  2. The ringer will alert once every 5 seconds for one minute. It will then shut off.
  3. The alarm will not ring again the next day unless reprogrammed.
  4. On the professional set, if the **OFF** soft key is not pressed to turn off the alarm when it activates, the words 'ALARM ON' will remain on the display until the **keyset** is used again.

**DEFAULT:** The alarm clock setting is empty for all stations.

---

## ATTENDANT

Two sets may be designated as attendants. Each attendant will serve one zone. Calls from stations in each zone will be routed to the corresponding attendant if:

A user dials 0 in Intercom.

An incoming line call is transferred, and no party answers.

A user invokes the Do Not Disturb (DND) feature after an incoming intercom call starts to ring.

A caller is using Direct Inward System Access (DISA) and dials '0' or dials incorrectly (the **caller** is routed to the attendant for Zone One).

Either attendant may change the System Service Mode (Day, Night, or Time) from their respective station. See **SYSTEM SERVICE MODE** for programming details.

The optional **DSS/BLF** DKS 940 console provides the attendant with indicators and keys for all lines and stations.

## PROGRAMMING

To assign attendants for either Zone:

See System Programming • Resource/ Attendant (5.4.2)

To assign stations to a particular Zone:

See System Programming • Set/ Zone Number (5.1.6)

To install **DSS/BLF** consoles:

See System Programming • Set/ **DSS/BLF** (5.1.10)

---

# FEATURES

## ATTENDANT, cont'd

**NOTE:** To designate a station as the attendant for a zone, the station must first be assigned to the zone.

**DEFAULT:** 1. All stations are assigned to Zone 1. The attendant station for Zone 1 is station 10.  
2. There is no attendant for Zone 2.

## AUTOMATIC BUSY REDIAL (ABR)

The KSU can automatically redial busy numbers at specified intervals until the line becomes free or a predetermined number of attempts is reached.

### OPERATION

Press: **F - 7 - 5**

The KSU will redial the **last** number. If the line rings or if the called party answers, lift the handset or, on a Professional **keyset**, start conversing in handsfree mode.

If the line you are trying to reach is busy, ABR will hang up and repeat **dialing** the number automatically at specified time **intervals**. This will continue until a ring back is detected or until the **predetermined** maximum number of attempts allowed is reached.

### PROGRAMMING

See System Programming - Call Handling/ Automatic Busy Redial (5.3.12)

**NOTES:** 1. This feature requires the installation of a DKS 55 option board to operate.

2. If the line used for the Last Number Redial is busy, the system will select another available line.

3. **Pressing** any of the following keys will stop the ABR process, even in between attempts:

**F - \* - 7 - 5** (or the feature key programmed for ABR)

**RLS** key

**Handsfree** key

**Intercom** key

**Line** key

**Pool** key

**Redial** key

4. **Other** feature programming and operations will not stop the ABR process.

5. The **HOLD** key is inoperable when ABR is activated

**DEFAULT:** 1. The time interval between the attempts is 60 seconds.

2. The number of attempts made is 5.

---

# FEATURES

## **DIRECT STATION SELECT (DSS), cont'd**

Or, if DSS has priority (see *DSS/SPD KEY PRIORITY*),

Press: **DSS** key for the station you wish to call (there is no need to press the **Intercom** key first).

**NOTES:** 1. This feature is available on the Professional keyset only.

2. The **SHIFT** key provides for a second page of DSS numbers. For example, pressing the first DSS key will dial station 10. Pressing the **SHIFT** key, then the DSS key will dial station 22.
3. The **SHIFT** key is a toggle key. **When** SHIFT is active, the LED will be lit.
4. If station number 10 (for example) changes its station number by reprogramming, the position of its DSS key on all sets will still remain the same (in this example, the first key).

**DEFAULT:** 1. SPD has priority.

2. Each **DSS** key is associated with the **default** station numbers as shown below:

Station 10/ Station 22	Station 16/ Station 28
Station 11/ Station 23	Station 17/ Station 29
Station 12/ Station 24	Station 18/ Station 30
Station 13/ Station 25	Station 19/ Station 31
Station 14/ Station 26	Station 20/ Station 32
Station 15/ Station 27	Station 21/ Station 33

## **DSS/SPD KEY PRIORITY**

The Professional keyset has 12 keys that may function as Direct Station Select or Speed Dial keys.

The system administrator may select whether the DSS function or the SPD function occurs if the key is pressed while the phone is idle.

If **DSS** has priority, then pressing a **DSS/SPD** key will initiate an Intercom call.

If **SPD** has priority, then pressing a **DSS/SPD** key will initiate a Speed Dial call.

---

# FEATURES

---

## ***DSS/SPD KEY PRIORITY, cont'd***

**OPERATION** (Professional keyset only)

If **DSS** has priority:

To make an Intercom call,

Press: **DSS/SPD** key (or **SHIFT + DSWSPD** key) for the station you want to call.

To make a Speed Dial call,

Press: a **Line** key.

Press: **DSS/SPD** key (or **SHIFT + DSWSPD** key) of the Speed Dial number you wish to call.

If **SPD** has priority:

To make an Intercom call,

Press: **INTERCOM** key.

Press: **DSWSPD** key (or **SHIFT + DSWSPD** key) for the station you want to call.

To make a Speed Dial Call,

Press: **DSWSPD** key (or **SHIFT + DSS/SPD** key) of the Speed Dial number you wish to call.

The system will automatically access a line and dial the number programmed for that key.

## **PROGRAMMING**

To select DSS or SPD priority,

see System Programming • Call Handling/ DSWSPD Function Key Priority (53.13)

**NOTE:** If the DSWSPD key(s) on a DKS 930 are programmed as Feature or Line keys, they will lose their DSWSPD capabilities. Refer to **FEATURE KEY PROGRAMMING** for details on how to reprogram the keys to have DSS/SPD capability.

**DEFAULT:** SPD has priority.

---

## ***DISCRIMINATING RING***

Intercom calls and line calls have a different ring cadence so the user can easily distinguish the two.

Intercom Ringing: 1 second on, 2 seconds off

Line Ringing: 2 seconds on, 4 seconds off

---

## ***DISTINCTIVE STATION RING***

Stations may be programmed to have one of four different ring types, Each type is a different frequency.

## **PROGRAMMING**

**Professional keyset:**

Press: **F - # - 7**. Present ring will sound.

Press: **CHG** key repeatedly until the desired ring type appears on the display. Each ring type will sound.

Press: **RLS** (Release) key.

---

# FEATURES

---

## **CALL AGAIN, cont'd**

### **OPERATION**

#### **Professional keyset:**

After no answer or a busy signal on an intercom call,

Press: the **RECALL soft** key.

When the called party hangs up, your set will ring.

You may lift your handset. Your station will call the other station back automatically,

To initiate a handsfree call from your station to the other station,

Press: the **REPLY soft** key.

To cancel the feature with no call made,

Press: **F - \* - 9 - 1**, OR, when your set rings,

Press: the **DEL (DELETE)** soft key.

#### **Associate keyset:**

After no answer or a busy signal on an intercom call,

Press: **F - 9 - 1**

When the called party hangs up, your set will ring.

You may lift your handset. Your station will call the other station back automatically.

To cancel the feature with no call made,

Press: **F - \* - 9 - 1**

- NOTES:**
1. Any station may have *only* one Call Again request towards it.
  2. A station may make only one Call Again request at a time.
  3. If there is no answer at the called party, the Call Again feature will be invoked when the called party returns, makes a call, then hangs up.

---

## **CALL ATTENDANT**

Any user may call the attendant for his zone by getting an intercom dial tone, then dialing **"0"**.

### **PROGRAMMING**

A set must be designated as the attendant for that zone in system programming. See System Programming-Resource/ Attendant (5.4.2).

- DEFAULT:**
1. Station **10** is the attendant for Zone 1.
  2. All stations are assigned to Zone 1.

---

# FEATURES

## **CALL FORWARD**

Some types of **calls** may be directed to another station by using Call Forwarding. \*The following types of calls may be forwarded:

1. Intercom calls
2. External (C.O. Line) incoming calls that have been answered once, then transferred to the forwarding station ("answered" calls).

Unanswered, or "initial", **calls** may be directed to other stations by using the Delayed Ring feature. An "initial" call is an incoming call that has not been answered yet and is ringing at the station or Hunt Group with ring assignment for that line. To redirect initial calls, see **DELAYED RING**.

There are three types of Call Forwarding:

1. Busy Call Forward - Forwards calls only if the station is in use.
2. No Answer Call Forward - Forwards calls only if there is no answer.
3. Direct Call Forward - Forwards all calls.

Busy Call Forward and **No** Answer Call Forward are programmed and enabled by the system programmer. The user may program Direct Call Forward at his or her station.

## **OPERATION**

### **Professional keyset:**

If Station 11 is forwarding calls to station 15, and the user at station 12 dials station 11, the display at station 12 will show one of the following (station 15 will ring in all cases):

1. 11 BUSY CFW > 15 (for Busy Call Forward)
2. 11 NO ANS CFW > 15 (for No, Answer Call Forward)
3. 11 DIR CFW > 15 (for Direct Call Forward)

## **STATION PROGRAMMING** (Direct Call Forward)

### **Professional keyset only:**

Press: **F - 2**.

Enter: the station number to which you want to forward calls.

Press: the **SAVE soft** key

To cancel Call Forward,

Press: the **CANCEL soft** key.

### **Associate keyset:**

The Associate **keyset** can not use Direct Call Forward.

## **SYSTEM PROGRAMMING** (Busy and No Answer Call Forward)

See System Programming - Set/ Call Forward (5.1.9)

# FEATURES.

## EXTERNAL CALL FORWARD (ECF), cont'd

### PROGRAMMING

1. The incoming and outgoing ECF lines must be selected in System Programming - Call Handling/ External Call Forward (53.11).
2. The number to be dialed must be programmed in Speed Dial location 99.
3. The activation time for ECF may be programmed as DAY, NIGHT or ALWAYS.
4. To program Loop Break Detection, see System Programming - Peripheral/ Loop Break Detection (5.6)

**NOTES:** 1. This feature requires the installation of a DKS 55 option board to operate.

2. The allowed line-to-line conversation time is 7 minutes.

3. If the outgoing ECF line is busy, a ringing incoming ECF line will not be answered.

4. If no number is programmed into Speed Dial location 99, the incoming ECF line will not be answered.

5. A line may be programmed as a DISA Line or an ECF Line, but should not be programmed as both at once.

**DEFAULT:** 1. ECF is disabled.

2. No lines are specified as incoming or outgoing ECF lines.

3. Loop Break Detection is enabled.

4. Activation time: DAY

## FEATURE ACCESS CODES

The codes listed below are used to program feature keys (see page 29) and to access features during use. Codes will be visible on the Professional keyset display.

F1	SPEED DIALING
F2	CALL FORWARD (P)
F3	FLASH
F4	DO NOT DISTURB (P)
<b>F50</b>	PAGING
F51	SAVED NUMBER REDIAL
F52	BACKGROUND MUSIC
F53	CALL PARK
F54	GROUP PICKUP
<b>F55</b>	LCD CONTRAST (P)
F56	OHVA (OFF HOOK VOICE ANNOUNCE) (A)
<b>F57</b>	PRIVATE TALK (A)
F58	CALL PARK ANSWER
F59	PAGING ANSWER
F6	CONFERENCE
<b>F70</b>	PAUSE
<b>F71</b>	ACCOUNT CODE
F72	LONG DTMF TONES
F73	CALL MONITORING
F74	FORCED RELEASE (A)
F75	AUTOMATIC BUSY REDIAL (ABR)
F76	DEFAULT SETTING

F77	MUTE (P)
F78	MODEM SETUP
F79	DATA RATE SELECT (P+)
F8	LAST NUMBER REDIAL (P)
<b>F90</b>	ADVISORY MESSAGE (P)
<b>F91</b>	CALL AGAIN
F92	ALARM
F93	CAMP ON BUSY LINE
F94	AUTOMATIC HOLD
F95	AUTO LINE SELECT
F96	MESSAGE WAITING
F97	SET LOCK/UNLOCK
F98	VOICE CALL ALLOW
<b>F99</b>	AUTO DATA ON (P+)
<b>F9*</b>	VOICE MAIL (VM)
<b>F9#</b>	LEAST COST ROUTING (LCR)
F0	FEATURE ACCESS CODE (P)
<b>F#3</b>	FEATURE KEY PROGRAMMING (P)
<b>F#7</b>	DISTINCTIVE RING
<b>F#8</b>	STATION FEATURE STATUS CHECK (P)
F#0	SYSTEM SERVICE MODE
<b>F##</b>	SYSTEM PROGRAM (P)

<b>P :</b> PROFESSIONAL KEYSSET ONLY
<b>P+ :</b> PROFESSIONAL PLUS KEYSSET ONLY
<b>A :</b> ASSOCIATE AND ASSOCIATE PLUS KEYSSETS ONLY

To Cancel a Programmed Feature:  
Press: F . \* . Access Code

---

# FEATURES

2

## FEATURE KEY PROGRAMMING

The nine Feature keys of all the Professional keysets (DKS 925, 930, 935) may be programmed as Line keys, Feature keys, or a Data key (DKS 935 Only). In addition, on the DKS 930, the twelve DSS/SPD keys may also be programmed as Line keys or Feature keys. On the Associate Plus (DKS 830), the seven Feature keys may be programmed as Line keys or Feature keys. Any feature available via a feature access code may be programmed onto a key. Pressing the key will have the same effect as entering the code.

For example, the fourth key is programmed as Line 4 at the factory. If your system or station does not use Line 4, you may wish to change the function of that key to a different function from the list of available functions.

## OPERATION

Press the programmed feature key.

## PROGRAMMING

**Professional keyset only:**

Press: **F # 3**

Press: **FEATURE** key you want to reprogram. The display will show the present feature of the key.

To change it,

Press: **CHG** (change) soft key.

Select: **LINE**, **DATA**, or **FTR** (feature) soft key type.

The display will show you the various options for the type of key you selected.

If **DATA** soft key is selected,

A beep will be heard indicating completion of programming.

If **LINE** soft key is selected,

Press: Line Number (1-6)

Press: **SAVE** soft key,

Or,

To make the key a Line Pool key,

Press: 00 for general pool (Pools 1-8)

Press: **01** for Pool 1

Press: 02 for Pool 2 and up to 08 for Pool 8

Press: **SAVE** soft key.

If **FTR** (Feature) soft key is selected,

**Press: FEATURE CODE** of the desired feature (e.g., **F-4** for **Do Not Disturb**).

Press: **SAVE** soft key. A beep tone will be heard to confirm completion.

**Associate Plus keyset only:**

Replace the Associate Plus keyset with any Professional keyset and follow the same steps as noted for the Professional keyset.

See DKS 830 User Instruction Guide • Programming Features onto Programmable Keys for more detail.

---

# FEATURES

---

## CALL PICKUP (GROUP), cont'd

**NOTES:** 1. There are 8 Groups available.

2. The priority for Call Pickup is:
  1. incoming Line Call
  2. Recalled Line Call
  3. Transferred Line Call
  4. Camped Line Call
  5. Call Again ICM Call
  6. Incoming ICM Call
  7. Intercom Voice Call

If two calls are ringing at once, the call whose type is nearer the top of the list will be picked up.

3. The user must press **F - 5 - 4** before lifting the handset or pressing the **HANDSFREE** key to activate the Call Pickup feature.

**DEFAULT:** All stations are in Group 1.

---

## CAMP ON BUSY LINE

If a user wants to make a call on a particular line and the line is busy, the user can camp on the line. When the line becomes free, the user's phone will ring.

### OPERATION

**Professional keyset:**

Press: a **LINE** key (of a busy line).

Press: the **CAMP soft** key.

When the line becomes free, and your phone rings:

Press: the **LINE** key or lift the handset to access the line.

To cancel,

Press: **F - \* - 9 - 3**

**Associate keyset:**

When a busy signal is heard,

Press: **F - 9 - 3**

When the line becomes free and the phone rings,

Lift the handset.

Press: **F - \* - 9 - 3**

**NOTES:** 1. Only one station may camp on a busy line at one time.

2. If a user tries to camp on a line that someone else is already camped on, the user's phone will give a double beep.

---

# FEATURES

## **CLASS OF SERVICE**

Each station may be assigned a **Class Of Service (COS)** from 0 (highest) to 7 (**lowest**). These COS are defined by System Programming, and refer to Toll Restrictions.

Each Line may also be assigned a COS. The System Programmer will decide what Toll Restrictions apply to each COS, for both DAY and NIGHT service, then assign a COS to each Line and Station.

## **OPERATION**

When the user tries to dial a call that is restricted, the station will return to idle condition, and an error beep will be heard. The beep will stop when the user performs another action, such as pressing a **Line** key or the **RLS** key.

## **PROGRAMMING**

See System Programming - Restriction/ Toll Restriction (5.51).

**DEFAULT:** Each station's and line's Day COS and Night COS is 0.

---

## **CONFERENCE**

A conference call may be made with up to four participants, two of which may be on outside lines.

## **OPERATION**

### **Professional keyset:**

Make a call.

Press: **HOLD**

Make a second call.

Press: the **CONF** (conference) soft key. The two parties and yourself will now be in conference.

To add a fourth party:

Press: **HOLD**.

Make another call.

Press: the **CONF** soft key. All four parties are now in conference.

To drop a party from the conference (forced release):

Press: the **DROP** soft key.

Enter the station number you wish to drop, or press the Line key of the call you would like to drop.

If you decide not to drop a call,

Press: the **EXIT** soft key.

To have a private call with one of the parties in the conference:

Press: the **PRIV** (private) soft key.

Enter the station number of the party you wish to speak with, or press the Line key of the party, You will be connected with that party only.

To return to the conference:

Press: the **CONF** soft key.

---

# FEATURES

---

## HANDSFREE

A Professional **keyset** may be used in Speakerphone mode by pressing the **HANDSFREE** key.

### OPERATION

**Professional keyset** only:

Press: **HANDSFREE** key.

- NOTES:**
1. Handsfree may be used for Intercom or Line calls.
  2. The feature is available **only** on the Professional (DKS 925, DKS 930 and DKS 935) **keysets**.

---

## HEADSET COMPATIBILITY

To replace the handset of a digital **keyset** with a headset, use the Automatic Line Selection feature (F95) to select 'NONE'. In this case, if the hook switch is not depressed, the set will remain in the idle state. A line or Intercom dial tone may be obtained by pressing the appropriate line or the **INTERCOM** key.

### OPERATION

If Automatic Line Selection is set to 'NONE',

Press: a Line or Pool key to answer or make a line call.

Or,

Press: the **INTERCOM** key to answer or make an Intercom call.

To transfer or perform other functions, follow the normal procedures for those functions, with the following exception: Any time a procedure requires that the handset be hung up, press and release the hook switch instead. Do not press the **RLS** key unless you wish to terminate the call.

To terminate the call:

Press: the RLS key.

---

## HEARING AID COMPATIBILITY

All handsets are compatible with properly equipped hearing aids as defined by the FCC Part 68 rules.

---

## HOLD

A user may put any line call or Intercom call on hold. Background music may be played to the held party if the system is equipped to do so.

### OPERATION

**Professional keyset:**

Press: **HOLD** key.

To retrieve a line call that is on hold,

Press: **LINE** key of the held call.

Or,

Press: **HOLD** key to retrieve the call if you do not have a programmed Line key for that particular line.

# FEATURES

## **DATA CALL (DKS 935 ONLY)**

The DKS 935 serial data port is a basic tool for establishing two way data communication over the Landmark system wiring, without the need for separate, dedicated network wires. This link operates via the RS232 port on the DKS 935.

The Serial port configuration can be useful primarily for custom applications (such as a customer-designed e-mail network), or as a Simple method for sharing a serial printer, or other applications where the flow control between the DTE and the DCE devices is not important.

## OPERATION

**Professional Plus keyset with Data Port (DKS 935) only:**

Press: **DATA** key.

Enter: the **STATION NUMBER** of the destination keyset.

To answer the Data Call (called party),

Press: **DATA** key.

To reject a Data Call (called party),

Press: **REJECT** soft key.

Either party may end the call:

Press: **DATA** key.

## PROGRAMMING

You may choose to program Auto Answer for Data Calls. When a Data Call request comes to your station, you will not have to press any key to answer. The connection will be made automatically.

To Auto Answer Data Calls:

Press: **F - 9 - 9**

To cancel Auto Answer:

Press: **F - \* - 9 - 9**

To program a feature key as a DATA key, see **FEATURE KEY PROGRAMMING**.

## SAMPLE SET-UP

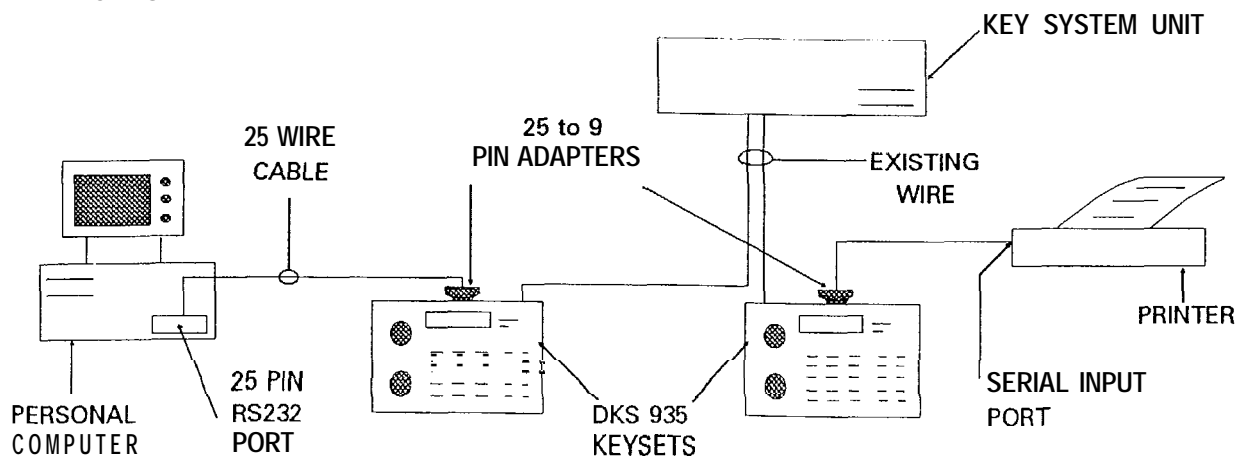

---

# FEATURES

## **DATA CALL (DKS 935 ONLY), cont'd**

A data link may be established between two DKS 935 keysets. This link operates via the RS232 port on the DKS 935, and will accommodate whatever protocol is established by the users communication devices.

### **PIN CONFIGURATION**

The pinout of the serial connector follows:

PIN	DESIGNATION.
1	No Connection
2	Receive Data
3	Transmit Data
4	DTE Ready
5	Ground
6	DCE Ready
7	Request to Send (Pins 7 & 8 shorted)
8	
9	No Connection

When a data call is made, there is a reversal of data pairs between phones similar to a null modem. Pins 2 and 3 are reversed, and 4 and 6 are reversed.

### **PC SETTINGS**

Under "Printer Setup", select "Connect...". In the "CONNECT" window, select an available serial port (COM 1, COM 2, etc.).

Then, select "SETTINGS". In the "FLOW CONTROL" window, select "NONE".

- NOTES:
1. The only way to abandon a Data Call is by pressing the DATA key.
  2. The system provides only a connection. No transmission protocol is provided. A customer-supplied software package at the PC must provide protocol handling, error processing, re-transmission, etc.
  3. The data rate must be selected to match the customer's protocol. See *DATA RATE SELECTIO*

### **LIMITATIONS**

If your software or hardware applications require control circuits that are included in the EIA RS232 standard, but that do not appear on the DKS 935 serial data port (for example, "RCF Line Signal Detector" or "Ring Indicator"), your application will not be compatible through the DKS 935 data port.

Since pins 7 and 8 are shorted together (this is a common "work around" to provide some of the functionality of extra control circuits without the actual connections), some applications requiring those signals may not work.

---

# FEATURES

---

## DATA RATE SELECTION

The data rate for Data Calls may be selected.

### OPERATION

**Professional Plus keyset** with Data Port (DKS 935) only:

Press: **F - 7 - 9**

Press: the **CHG soft** key until the desired data rate appears on the display.

Press: **RLS** (release) key.

**NOTE:** The baud rate is selectable from 2400, 4800, 9600 and 19200 bps.

**DEFAULT:** 9600 bps.

---

## DEFAULT STATION SETTINGS

This feature resets all programmable station settings to their default values.

### OPERATION

**Professional keyset:**

Press: **F - 7 - 6**

Enter: 4-digit password

Press: **SHOW soft** key.

To return to default settings,

Press: **YES soft** key.

To **exit** without changing settings,

Press: **NO soft** key.

**Associate keyset:**

Press: **F - 7 - 6**

Enter: 4-digit password.

Station will return to default settings.

**NOTE:** The entire System (including the stations) may be returned to default, See System Programming - Resource/ Default Setting (54.16).

**DEFAULT:** Individual Stations: Feature keys (Professional keyset only):

Do Not Disturb:	Disabled	Line 1	Page
Automatic Hold:	Enabled	Line 2	Flash
User Password:	0000	Line 3	Forward
Station Lock/Unlock:	Unlocked	Line 4	Pickup
Distinctive Ring Type:	<b>Type 1</b>	Redial	
Data Rate:	9600 bps		
Auto Line Selection:	Intercom		
Voice Call Allow:	On		
Direct Call Forward:	Disabled		
Last Number Redial (LNR):	Empty		
Saved Number Redial (SNR):	Empty		

---

# FEATURES

## **DELAYED RING**

Delayed Ring is a method of making unanswered incoming C.O. line calls ring, after a programmed delay, at different stations or hunt groups. This allows unanswered line calls to ring at a Voice Mail or Automated Attendant port, at another station, or at a different hunt group.

Two Delayed Ring destinations, may be programmed for each line. When the delay time passes without the call being answered by any of the stations with ring assignment for that line, the call will begin to ring at Destination One (station or hunt group). If there is no answer at the first destination after another delay period, the call will ring at Destination **Two**.

If the destination is a Voice Mail port or a Hunt Group, the system will send a "Reason" and "Originator" DTMF header to the port when the call is answered, if so programmed. The Reason is the "Initial Call" header and the Originator is the line identifier (mailbox number) programmed for the line. For each line, the Reason and Originator headers may be individually programmed to be sent or not.

## **PROGRAMMING**

To program Destination One and Destination Two for a C.O. line, set the delay time for a line, assign a mailbox number (Originator header) to the line, or select whether "Reason" and "Originator" headers should be sent to voice mail ports for an initial line call,

see System Programming • Line/ Delayed Ring (5.2.8)

To assign a DTMF code to the "Initial Call" Voice Mail header,

see System Programming • Peripheral/ Voice Mail (5.6.5)

- NOTES:**
1. Stations with 'Ring Assignment' set to 'Y' will ring on an incoming call until the delay time has expired. They will then stop ringing and 'Destination One' will start to ring. After a second delay (equal in time to the first), 'Destination Two' will start to ring and 'Destination One' will stop.
  2. If there is no answer, the final destination will continue to ring until the incoming ring signal ceases.
  3. The DTMF headers for 'Reason' and 'Originator' initial calls are programmed in different section in System Programming (see PROGRAMMING, above). The Initial Call 'Reason' header is the same for all lines, but the 'Originator' header is programmed separately for each line.
  4. The selection of whether or not to send 'Reason' and 'Originator' headers for Delayed Ring call is made separately for each line (see PROGRAMMING, above).
  5. Delayed Ring is disabled if any of the following are true:
    - a. Delayed Ring is set to 'NONE'.
    - b. First and Second destinations are set to 'NONE'.
    - c. A Hunt Group is a destination, but there are no member stations assigned to the Hunt Group.

- DEFAULT:**
1. Delayed Ring time is 'None' for all lines (no Delayed Ring).
  2. Destinations One and Two are 'None' for all lines.
  3. 'Reason' and 'Originator' headers are not sent for any lines.
  4. Mailbox number is 'Empty' for each line.
  5. Initial Call header is 'Empty'.

---

# FEATURES

## ***DIALING TYPE SELECTION***

Dialing on outside lines may be either in Pulse mode or DTMF (Dual Tone Multi-Frequency).

### **PROGRAMMING**

See System Programming ■ Line/ Dialing Type Selection (52.2).

**DEFAULT:** DTMF

## ***DIALING INTERCOM***

All stations may call each other by dialing 2-digit codes.

### **OPERATION**

#### **Professional keyset:**

Handset Call:

Lift handset.

If your auto-line selection is NOT set to Intercom, then

Press **INTERCOM** key.

Enter 2-digit station number you are calling, or press the DSS key for that station.

Handsfree Call:

Press: **INTERCOM** key.

Or,

If your auto-line select is set to Intercom,

Press: **HANDSFREE** key.

Enter: 2-digit station number you are calling, or press the DSS key for that station.

The called party may answer by lifting the handset or pressing the **HANDSFREE** key.

#### **Associate keyset:**

Lift handset.

If your auto-line select is NOT set to Intercom,

Press: **INTERCOM** key.

Enter: **2-digit** station number you are calling.

The called party may answer by lifting the handset.

- NOTES:**
1. To make a Voice Call to any station, press **'\*'** after dialing. Your voice will immediately be heard through the called set's speaker. If the called set is a Professional, the party may reply by speaking, as in a speakerphone call. If the called set is an Associate, the party may lift the handset to reply.
  2. A station may be programmed to treat all received Intercom calls as Voice Calls. See **VOICE CALL**.

---

# FEATURES

## ***DIRECT DIALING IN (DDI)***

One external line may be set up so that a remote caller can dial into any station just by entering the station number, without any password or attendant. This is called Direct Dialing In (DDI).

### OPERATION

When a remote user makes an incoming call on the DISA line, after a programmed number of rings he will hear a special dial tone. The user may then dial any valid station number, and that station will ring.

**NOTES:**1. This feature requires the installation of a DKS 55 option board to operate.

2. The Line must be programmed as a DISA Line (see Direct Inward System Access).

3. If the caller dials an incorrect station number, the call will be directed to the attendant.

4. If the caller pauses more than 10 seconds between digits, the call will be directed to the attendant.

5. If the caller dials the digit "0", the call will be directed to the attendant,

DEFAULT: No lines are selected as active DISA lines.

## ***DIRECT INWARD SYSTEM ACCESS (DISA)***

This system allows a remote user with the correct password to dial into the system through a pre-programmed line and to have access to all the system resources for making intercom or outgoing calls.

In addition, the line may be set up so that a remote caller can dial into any station just by entering the station number, without any password or attendant (see Direct Dialing In).

### OPERATION

Caller dials into system on a Line programmed as a DISA line. After the programmed number of rings, the caller will hear a special dial tone.

The caller should:

Press: \*

Enter: 8-digit password

Press: \*

The system will provide an intercom dial tone.

To make an intercom call, the caller should:

Press: \*

Enter: 2-digit station number.

To make an outside line call, the caller should-

Press: 3

Enter: Line number (1-6). A dial tone will be heard.

To make an outside line call using Least Cost Routing,

Press: 9

Enter: telephone number

---

## FEATURES

### ***DIRECT INWARD SYSTEM ACCESS (DISA), cont'd***

To end the outside line call and get another intercom dial tone,  
Press: \* - \*

To end the call completely,  
Press: \* • 9

Or,  
Only if Loop Break Detection is enabled, hang up.

When the allowed time is about up, you will hear a short busy tone.

To extend the allowed time on the outside line,

Press: \*

### **PROGRAMMING**

To program the DISA Access Code,  
see System Programming - Call Handling/ DISA Access Code (5.3.10)

To program a DISA line as active in DAY, NIGHT, or ALWAYS,  
see System Programming - Call Handling/ DISA (5.3.9)

To enable Loop Break Detection,  
see System Programming - Peripheral/ Loop Break Detection (5.6.7)

**NOTES:** 1. This feature requires the installation of a DKS 55 option board to operate.

2. If Loop Break Detection is NOT enabled, the user must press \* - 9 to end the call. Otherwise, the line may remain active for up to 15 minutes.

3. The allowed line-to-line conversation time is 15 minutes

4. There are up to 24 DISA passwords allowed. Each is 8 digits in length, followed by a COS (one digit).

5. A COS must be programmed for DISA calls. It is entered **after** the eighth digit of the DISA Access Code. For example, if the code is 12345678, and a COS of 1 is desired, the digits 123456781 are entered in system programming when prompted for the DISA Access Code.

**DEFAULT:**

1. No Lines are selected as active DISA lines.
2. The DISA passwords are empty.
3. The default number of rings before answering is one.
4. Loop Break Detection is enabled.

---

### ***DIRECT STATION SELECT/ON (DSS)***

The Professional **keyset** is equipped with 12 Direct Station Selection keys. The user may press any of these keys to dial an intercom extension, instead of dialing the **2-digit** number.

### **OPERATION**

**Professional keyset** only

Press: **INTERCOM** key

Press: **DSS** key for the station you want to call

---

# FEATURES

## ***DIRECT STATION SELECT (DSS), cont'd***

Or, if DSS has priority (see *DSS/SPD KEY PRIORITY*),

Press: DSS key for the station you wish to call (there is no need to press the Intercom key first).

NOTES: 1. This feature is available on the Professional keyset only.

2. The SHIFT key provides for a second page of DSS numbers. For example, pressing the first DSS key will dial station 10. Pressing the SHIFT key, then the DSS key will dial station 22.
3. The SHIFT key is a toggle key. When SHIFT is active, the LED will be lit.
4. If station number 10 (for example) changes its station number by reprogramming, the position of its DSS key on all sets will still remain the same (in this example, the first key).

DEFAULT: 1. SPD has priority.

2. Each DSS key is associated with the default station numbers as shown below:

Station 10/ Station 22	Station 16/ Station 28
Station 11/ Station 23	Station 17/ Station 29
Station 12/ Station 24	Station 18/ Station 30
Station 13/ Station 25	Station 19/ Station 31
Station 14/ Station 26	Station 20/ Station 32
Station 15/ Station 27	Station 21/ Station 33

---

## ***DSS/SPD KEY PRIORITY***

The Professional keyset has 12 keys that may function as Direct Station Select or Speed Dial keys.

The system administrator may select whether the DSS function or the SPD function occurs if the key is pressed while the phone is idle.

If DSS has priority, then pressing a DSS/SPD key will initiate an Intercom call.

If SPD has priority, then pressing a DSS/SPD key will initiate a Speed Dial call.

---

# FEATURES

---

## ***DSS/SPD KEY PRIORITY, cont'd***

### **OPERATION** (Professional keyset only)

If **DSS** has priority:

To make an Intercom call,

Press: **DSS/SPD** key (or **SHIFT + DSWSPD** key) for the station you want to call.

To make a Speed Dial call,

Press: a **Line** key.

Press: **DSWSPD** key (or **SHIFT + DSWSPD** key) of the Speed Dial number you wish to call.

If **SPD** has priority:

To make an Intercom call,

Press: **INTERCOM** key.

Press: **DSS/SPD** key (or **SHIFT + DSWSPD** key) for the station you want to call.

To make a Speed Dial Call,

Press: **DSS/SPD** key (or **SHIFT + DSWSPD** key) of the Speed Dial number you wish to call.

The system will automatically access a line and dial the number programmed for that key.

### **PROGRAMMING**

To select **DSS** or **SPD** priority,

see System Programming - Call Handling/ **DSS/SPD** Function Key Priority (5.3.13)

**NOTE:** If the **DSS/SPD** key(s) on a DKS 930 are programmed as Feature or Line keys, they will lose their **DSS/SPD** capabilities. Refer to *FEATURE KEY PROGRAMMING* for details on how to reprogram the keys to have **DSWSPD** capability.

**DEFAULT:** **SPD** has priority.

---

## ***DISCRIMINATING RING***

Intercom calls and line calls have a different ring cadence so the user can easily distinguish the two,

intercom Ringing: 1 second on, 2 seconds off

Line Ringing: 2 seconds on, 4 seconds off

---

## ***DISTINCTIVE STATION RING***

Stations may be programmed **to** have one of four different ring types. Each type is a different frequency.

### **PROGRAMMING**

**Professional keyset:**

Press: **F - # - 7**. Present ring will sound.

Press: **CHG** key repeatedly until the desired ring type appears on the display. Each ring type will sound.

Press: **RLS** (Release) key.

---

# FEATURES

---

## ***DISTINCTIVE STATION RING, conf'd***

### **Associate keyset:**

Press: **F** \* # \* 7. Present ring will sound.

Enter: 1, 2, 3 or 4. Selected ring will sound.

**DEFAULT:** Each station will ring with Type 1 frequency.

---

## ***DO NOT DISTURB***

A user may prevent any incoming Calls from ringing by enabling Do Not Disturb (DND).

### **OPERATION (Professional keyset Only)**

**Press: F - 4**

To cancel,

Press: **F \* \* - 4**

- NOTES:**
1. DND will not be allowed if Call Forward is enabled.
  2. If DND is enabled, the user will hear a special dial tone when trying to make an intercom call, to remind him that DND is enabled.
  3. A secretary station may override a Boss's DND. See ***DO NOT DISTURB OVERRIDE***.
  4. The DND function may be enabled after an incoming intercom call starts ringing. The caller will be forwarded to the Attendant. If the Attendant is busy, the caller will see the display "SET 10 IS BUSY" (if 10 is the Attendant).

**DEFAULT:** DND is disabled.

---

## ***DO NOT DISTURB OVERRIDE***

If the Boss/Secretary relationship is programmed, a secretary may override the Boss's DND.

### **OPERATION**

**Professional keyset** only (Secretary):

Press: **INTERCOM** key

Enter: Boss' station number.

If "**DND**" appears on the display,

Press: **OVERRIDE soft** key.

The call will appear as an intercom call to the called party,

### **PROGRAMMING**

See System Programming \* Call Handling/ Boss/Secretary Programming (5.3.8)

---

# FEATURES

---

## EXCLUSIVE HOLD

4 call put on Exclusive Hold can only be retrieved by the party that placed it on hold.

### OPERATION

#### Professional keyset:

Press: **FEATURE** key

Press: **HOLD** key

To retrieve a line call that is on Exclusive Hold,

Press: **Line** key of the held call.

Or, if you do not have a line key programmed,

Press: **HOLD** key

#### Associate keyset:

Press: **FEATURE** key

Press: **HOLD** key

To retrieve a line call that is on Exclusive Hold,

Press **HOLD** key

- NOTES:**
1. Only line calls may be placed on Exclusive Hold by pressing **F • HOLD** key. When an intercom call is placed on hold, it works similar to Exclusive Hold, but pressing **F • HOLD works** only on line calls.
  2. When a line call is on Exclusive Hold, it may only be retrieved by the station that placed it on hold.
  3. **When** a line call is on Exclusive Hold, its red LED will be lit steadily at the other stations.
  4. A call may be left on Exclusive Hold as long as desired. However, if the system service mode changes from DAY to NIGHT according to the preprogrammed service time, then all calls on Exclusive Hold will change to common hold.
  5. **When** Exclusive Hold is enabled, the user will hear a special dial tone when trying to use Intercom, to remind him that Exclusive Hold is enabled.

---

## EXTERNAL CALL FORWARD (ECF)

incoming line calls may be forwarded to a preprogrammed external phone number.

### OPERATION

**When** a call is received on the line preprogrammed as the incoming ECF line, the system will dial out on the outgoing ECF line. It will dial the number stored in Speed Dial location 99. It will establish a **line-to-line** conversation for the two lines.

To end the conversation and insure that both lines are released, the called party must

Press: **\* - 9**

Or,

Only if Loop Break Detection is enabled, hang up.

---

# FEATURES

---

## EXTERNAL CALL FORWARD (ECF), cont'd

### PROGRAMMING

1. The incoming and outgoing ECF lines must be selected in System Programming • Call Handling/ External Call Forward (5.3.11).
2. The number to be dialed must be programmed in Speed Dial location 99.
3. The activation time for ECF may be programmed as DAY, NIGHT or ALWAYS.
4. To program Loop Break Detection, see System Programming • Peripheral/ Loop Break Detection (5.6)

**NOTES:** 1. This feature requires the installation of a DKS 55 option board to operate.

2. The allowed line-to-line conversation time is 7 minutes.

3. If the outgoing ECF line is busy, a ringing incoming ECF line will not be answered.

4. If no number is programmed into Speed Dial location 99, the incoming ECF line will not be answered.

5. A line may be programmed as a DISA Line or an ECF Line, but should not be programmed as both at once.

DEFAULT: 1. ECF is disabled.

2. No lines are specified as incoming or outgoing ECF lines.

3. Loop Break Detection is enabled.

4. Activation time: DAY

---

## FEATURE ACCESS CODES

The codes listed below are used to program feature keys (see page 29) and to access features during use. Codes will be visible on the Professional keyset display.

F1	SPEED DIALING
F2	CALL FORWARD (P)
F3	FLASH
F4	DO NOT DISTURB (P)
F50	PAGING
F51	SAVED NUMBER REDIAL
F52	BACKGROUND MUSIC
F53	CALL PARK
F54	GROUP PICKUP
F55	LCD CONTRAST (P)
F56	OHVA (OFF HOOK VOICE ANNOUNCE) (A)
F57	PRIVATE TALK (A)
F58	CALL PARK ANSWER
F59	PAGING ANSWER
F6	CONFERENCE
F70	PAUSE
F71	ACCOUNT CODE
F72	LONG DTMF TONES
F73	CALL MONITORING
F74	FORCED RELEASE (A)
F75	AUTOMATIC BUSY REDIAL (ABR)
F76	DEFAULT SETTING

F77	MUTE (P)
F78	MODEM SETUP
F79	DATA RATE SELECT (P+)
F8	LAST NUMBER REDIAL (P)
F90	ADVISORY MESSAGE (P)
F91	CALL AGAIN
F92	ALARM
F93	CAMP ON BUSY LINE
F94	AUTOMATIC HOLD
F95	AUTO LINE SELECT
F96	MESSAGE WAITING
F97	SET LOCK/UNLOCK
F98	VOICE CALL ALLOW
F99	AUTO DATA ON (P+)
F9*	VOICE MAIL (VM)
F9#	LEAST COST ROUTING (LCR)
F0	FEATURE ACCESS CODE (P)
F#3	FEATURE KEY PROGRAMMING (P)
F#7	DISTINCTIVE RING
F#8	STATION FEATURE STATUS CHECK (P)
F#0	SYSTEM SERVICE MODE
F##	SYSTEM PROGRAM (P)

To Cancel a Programmed Feature:  
Press: F - \* - Access Code

<b>P</b> : PROFESSIONAL KEYSSET ONLY
<b>P+</b> : PROFESSIONAL PLUS KEYSSET ONLY
<b>A</b> : ASSOCIATE AND ASSOCIATE PLUS KEYSSETS ONLY

---

# FEATURES

## FEATURE KEY PROGRAMMING

The nine Feature keys of all the Professional keysets (DKS 925, 930, 935) may be programmed as Line keys, Feature keys, or a Data key (DKS 935 only). In addition, on the DKS 930, the twelve DSS/SPD keys may also be programmed as Line keys or Feature keys. On the Associate Plus (DKS 830), the seven Feature keys may be programmed as Line keys or Feature keys. Any feature available via a feature access code may be programmed onto a key. Pressing the key will have the same effect as entering the code,

For example, the fourth key is programmed as Line 4 at the factory. If your system or station does not use line 4, you may wish to change the function of that key to a different function from the list of available functions.

### OPERATION

Press the programmed feature key.

### PROGRAMMING

#### Professional keyset only:

Press: **F # 3**

Press: **FEATURE** key you want to reprogram. The display will show the present feature of the key.

To change it,

Press: **CHG** (change) soft key.

Select: **LINE**, **DATA**, or **FTR** (feature) soft key type.

The display will show you the various options for the type of key you selected.

If **DATA** soft key is selected,

A beep will be heard indicating completion of programming,

If **LINE** soft key is selected,

Press: **Line Number (1-6)**

Press: **SAVE** soft key,

Or,

To make the key a Line Pool key,

Press: **00** for general pool (Pools 1-8)

Press: **01** for Pool 1

Press: **02** for Pool 2 and up to **08** for Pool 8

Press: **SAVE** soft key.

If **FTR** (Feature) soft key is selected,

Press: **FEATURE CODE** of the desired feature (e.g., **F-4** for Do Not Disturb).

Press: **SAVE** soft key. A beep tone will be heard to confirm completion.

#### Associate Plus keyset only:

Replace the Associate Plus keyset with any Professional keyset and follow the same steps as noted for the Professional keyset.

See DKS 830 User Instruction Guide • Programming Features onto Programmable Keys for more detail.

---

# FEATURES

## FEATURE KEY PROGRAMMING, cont'd

- NOTES:
1. The Professional keyset (DKS 925, 935) has nine programmable feature keys.
  2. The DKS 930 has twelve programmable DSWSPD keys as well as nine programmable feature keys.
  3. (DKS 930 only) To change a **DSS/SPD** key that was programmed as a Feature key back to a **DSS/SPD** key, follow the procedure for programming as outlined above. Select 'FTR' as the type of function. When the system prompts for a Feature Code, make sure the field is blank, then press the SAVE soft key. The DSWSPD key will revert to its default function.
  4. On the DKS 925 and 935, the lower left feature key (default **"Redial"**) may be programmed as a Feature key, but not as a Line key. All other keys may be programmed as Feature, Data (DKS 935 only) or Line keys.
  5. A DATA key may be programmed on the DKS 935 only (Professional Plus keyset with Data Port).
  6. If a valid feature code entry is followed by an invalid digit then the invalid digits will be ignored, For example, the user enters **"F49"**. F4 is Do Not Disturb, the "9" is invalid. The key will be programmed for Do Not Disturb.
  7. All feature access codes are in the form of Fn or Fnn, where **"F"** is the feature key and n is a digit from 0 to 9, \*, or #.
  8. A list of Feature Access Codes is on page 28.

DEFAULT: 1. Default key assignments are as follows:

Associate Plus:

PAGE
FLASH
PICKUP
LINE 1
LINE 2
LINE 3
LINE 4

Professional:

LINE 1	PAGE
LINE 2	FLASH
LINE 3	FORWARD
LINE 4	PICKUP
REDIAL	

2. On the DKS 930 Professional keyset **DSS/SPD** keys, SPD has priority.

---

## FEATURES AND CODES MENU

This provides the user of the Professional keyset with a menu of features and codes, eliminating the need for memorization of codes. When accessing the menu, the user may press the GO soft key at any time to activate a displayed feature.

---

# FEATURES

## FEATURES AND CODES MENU, *cont'd*

### OPERATION

#### Professional keyset Only:

Press: F

Enter: 0

The display will show a feature name, followed by the code number used to access that feature.

To see the next or the previous feature code,  
Press **NEXT** or **BACK soft key**.

To activate the feature,  
Press GO soft key.

To exit without activating any features,  
Press **RLS key** (release).

- NOTES:**
1. The feature **may** be accessed by pressing the GO soft key only if the feature is appropriate at the time.
  2. The code F - 0 may be used during a call or when the station is idle.

### FLASH

A Flash of preprogrammed length may be entered when on a line call.

### OPERATION

Press: F - 3

### PROGRAMMING

See System Programming - Call Handling/ Flash (5.3.1).

- NOTES:**
1. A Flash may be stored in speed dial. It will appear as the letter "F" on the Professional keyset LCD.
  2. The Flash time is programmable from 0.1 seconds to 1.5 seconds, in 0.1 second increments.
  3. When a Flash (F3) is entered, the display will return to normal and the call duration timer will start after a ten second delay.

**DEFAULT:** Flash time is 600 ms.

---

# FEATURES

## **HANDSFREE**

A Professional **keyset** may be used in Speakerphone mode by pressing the HANDSFREE key.

### **OPERATION**

**Professional keyset** only:  
Press: **HANDSFREE** key.

- NOTES:**
1. Handsfree may be used for Intercom or Line calls.
  2. The feature is available only on the Professional (DKS 925, DKS 930 and DKS 935) keysets.

## **HEADSET COMPATIBILITY**

To replace the handset of a digital **keyset** with a headset, use the Automatic Line Selection feature (F95) to select 'NONE'. In this case, if the hook switch is not depressed, the set will remain in the idle state. A line or Intercom dial tone may be obtained by pressing the appropriate line or the **INTERCOM** key.

### **OPERATION**

If Automatic Line Selection is set to 'NONE',  
Press: a Line or Pool key to answer or make a line call.  
Or,  
Press: the **INTERCOM** key to answer or make an Intercom call.

To transfer or perform other functions, follow the normal procedures for those functions, with the following exception: Any time a procedure requires that the handset be hung up, press and release the hook switch instead. Do not press the **RLS** key unless you wish to terminate the call.

To terminate the call:  
Press: the **RLS** key.

## **HEARING AID COMPATIBILITY**

All handsets are compatible with properly equipped hearing aids as defined by the FCC Part 68 rules.

## **HOLD**

A user may put any line call or Intercom Call on hold. Background music may be played to the held party if the system is equipped to do so.

### **OPERATION**

**Professional keyset:**  
Press: **HOLD** key.

To retrieve a line call that is on hold,  
Press: **LINE** key of the held call.

Or,  
Press: **HOLD key** to retrieve the call if you do not have a programmed Line key for that particular line.

---

# FEATURES

---

## **OLD, cont'd**

To retrieve an Intercom call that is on hold,

Press: **INTERCOM key**.

### **Associate keyset:**

Press: **HOLD key**.

To retrieve a held line or intercom call,

**press: HOLD key**, or depress and release the hook switch.

- NOTES:**
1. A line call may be placed on common hold (anyone may pick up) or Exclusive Hold (only the party placing the call on hold may pick up - see *EXCLUSIVE HOLD*).
  2. When an intercom Call is placed on hold, only the party that placed it on hold may retrieve it.
  3. If a music source is connected, Music on Hold will be provided.
  4. When a call is placed on hold, the user will hear a special dial tone when trying to make an Intercom call, to remind him that a call is on hold.

---

## **OLD ABANDON**

The system may be programmed to release a line and terminate the connection if a line call is placed on hold and the caller hangs up.

In order for the system to recognize that the caller has hung up, the Central Office must supply a loop break, or disconnect, signal. Therefore, the Loop Break Detection feature must be enabled in order to use the Hold Abandon feature. This signal is sometimes provided a few seconds (normally one to fifteen) after the caller hangs up.

## **PROGRAMMING**

To enable Loop Break Detection and program the minimum time duration in which the system will detect the disconnect signal,

see System Programming - Peripheral/ Loop Break Detection (5.6.7).

- NOTES:**
1. When Loop Break Detection is enabled, Hold Abandon is also automatically enabled.
  2. Direct Inward Station Access (DISA) and External Call Forward (ECF) will operate differently when Loop Break Detection is enabled. Please refer to their respective descriptions for more details.
  3. Hold Abandon will operate on all lines when enabled.

---

## **OLD INDICATION**

Professional keyset:

The green line LED will flash quickly to indicate that a call was put on hold by the user at that station. At other professional stations, the red line LED will light steadily or flash slowly, depending on whether the call is in Exclusive Hold or common hold.

---

# FEATURES

---

## **HOLD INDICATION, con t'd**

### **Associate keyset:**

The Hold LED will flash quickly to indicate that a call was put on hold.

---

## **HOLD REMINDER**

If the user places an outside line on hold, a soft beep will be heard once every 60 seconds until the call is retrieved.

---

## **HOUR MODE SELECTION**

The display on the Professional keysets may be set to either standard 12 hour time with AM and PM indications, or 24 hour (military) time.

### **PROGRAMMING**

See System Programming - Resource/ Hour Mode Selection (54.14).

- NOTES:**
1. Only one mode is selectable for the entire system. All sets will display time in the same mode.
  2. When a user programs features that require time settings, he must always enter times in a 24 hour mode, even though the system may be displaying 12 hour mode. Such features include Alarm Clock setting, System Service Mode setting, etc.

**DEFAULT:** System is in 12-hour mode.

---

## **HUNT GROUPS**

The Landmark system provides eight Hunt Groups, any one of which may be designated as a Voice Mail Hunt Group (see Voice Mail).

The Hunt Groups are numbered from 82 through 89 (Group 1 is 82, etc.). Each Hunt Group can have up to 24 members (stations) assigned to it. The members are each assigned a number from 1 to 24.

When a C.O. Line that is programmed to be answered by the Hunt Group rings or if the station makes a call to the Hunt Group number, the system will select one of the idle member stations of the Hunt Group to ring.

The system may be programmed to use either one of two methods to select which member will ring:

### **1. Hunt from FIRST**

On each call, the system will select the member with the lowest number that is idle and ring that number.

### **2. Hunt from NEXT**

The system will remember which member was rung on the last call and will ring the next available member in the sequence. This distributes calls more evenly among members.

---

# FEATURES

---

## HUNT GROUPS, cont'd

### OPERATION

To make an Intercom call to a Hunt Group,

Obtain an Intercom dial tone,

Dial: the **2-digit Hunt Group** number (82-89).

### PROGRAMMING

To assign members to Hunt Groups,

see System Programming ▪ Resource/ Hunt Group Programming (5.4.18)

To designate a Hunt Group as Voice Mail,

see System Programming ▪ Resource/ VM Hunt Group Assignment (5.4.17)

To make a Hunt Group ring on specific lines,

see System Programming ▪ Line/ Hunt Group Answer (5.2.7)

To make a Hunt Group ring on specific lines after a delay,

see System Programming ▪ Line/ Delayed Ring (5.2.8)

- NOTES:**
1. A station can be assigned to more than one Hunt Group.
  2. Hunt Groups are programmed separately to **ring** on lines during the DAY and NIGHT periods.

- DEFAULT:**
1. All Hunt Group members are set to 'NONE'. Voice Mail Hunt Group **is** set to 'N' (NONE).
  2. 'HUNT FROM' is set to 'FIRST'.

---

## IN USE INDICATION

**When** the green Line LED is on at a station, that indicates the line is in use at that station. At other stations, the red Line LED is steadily lit.

---

## LAST NUMBER RED/AL

Pressing the **REDIAL** key, or the code F8, will cause the last number dialed to be redialed.

### OPERATION

**Professional keyset:**

Press: **REDIAL**. The last number dialed will be redialed on the same line it was originally dialed on.

If that line is busy,

Press: **AUTO LN** (Automatic Line) soft key. The set will select the next available line for your call.

Or

Press: **CAMP** soft key. The set will camp on the busy line (see **CAMP ON BUSY LINE**).

If you wish to preselect the line for redialing,

Press: **LINE** key

Press: **REDIAL** key. The call will be redialed on the line selected.

---

# FEATURES

---

## LAST NUMBER REDIAL, cont'd

### Associate keyset:

**Press: Redial** key. The call will dial on the previously used line. If that line is busy, a busy signal will be heard. In that case,

Press: **\***. The set will automatically select another idle line.

Or,

Press: **#**. The set will camp on the busy line.

- NOTES:**
1. If the system automatically selects a line on which to redial, a pause will be inserted before dialing, to insure access to a dial tone.
  2. Up to 31 digits may be stored in Last Number Redial.

**DEFAULT:** Last Number Redial has no number stored.

---

## LCD CONTRAST ADJUSTMENT

The user may adjust the contrast of the display on the Professional set.

### OPERATION

Press: **F - 5 - 5**

Press: **Volume Up** (right side of volume key) repeatedly to increase contrast.

Press: **Volume Down** (left side of volume key) repeatedly to decrease contrast.

Press: **RLS** (RELEASE) key.

- NOTES:**
1. There are eight levels of LCD contrast allowed, from 0 to 7.
  2. When **F55** is pressed, the display will show "=====" to indicate the present contrast level. Each "=" indicates one level.

**DEFAULT:** Contrast is set to level 5.

---

## LEAST COST ROUTING (LCR)

The system may be set up to automatically select lines for outgoing calls in order to achieve the most cost effective routing. The system can use the time of day and the number dialed to determine which line to use. It can also modify the dialed number in case digits need to be added or deleted. All these decisions are programmed by the system administrator.

### OPERATION

Press: **F - 9 - #**. When you hear the special dial tone, dial the desired number. The system will select the best line to use.

Or,

Press: **INTERCOM - 9**. When you hear the special dial tone, dial the desired number.

---

# FEATURES

## **LEAST COST ROUTING, cont'd**

### **DESCRIPTION**

LCR works by comparing the number dialed and other information to a series of tables. Based on these tables, an appropriate line pool is selected for the call and appropriate changes are made to the phone number, such as adding or deleting digits, before the system dials the call on the line selected.

The tables that are used are the following:

#### **1. Toll Restriction Table**

Checks to see if the number dialed is restricted - see TOLL **RESTRICTION**.

#### **2. Digit Comparison Table**

According to the number dialed and the day of the week, this table will assign one of the ten Time of Day Tables for further evaluation.

#### **3. Time of Day Tables**

According to the time of day, the table selected will assign an appropriate entry in the Line Pools Table.

#### **4. Line Pools Table**

This table lists the first, second, third, and fourth choice Line Pools for the outgoing call. It also assigns an entry in the Digit Modification Table (DMT).

#### **5. Digit Modification Table**

According to the entry specified, this table adds and/or subtracts digits from the dialed number,

### **PROGRAMMING**

The first step in programming the LCR tables is to make a complete list of calls that need special routing. For each group of numbers, write down which lines are the most economical for each day of the week and at different times during the day. List what digit modifications, if any, need to be made in each case. This information can be recorded in the tables provided (see **PROGRAMMING RECORDS**) and then used to program the LCR conditions as outlined in System Programming - Restriction/ Least Cost Routing (5.5.2).

To enable LCR for a particular station,  
see System Programming - Set/ LCR Enable (51.11)

To program toll restrictions,  
see System Programming - Restriction/ Toll Restriction (5.5.1)

There are four types of table which are used to accept LCR information; they include a Digit Comparison Table, Time of Day Tables, a Line Pools Table, and a Digit Modification Table. Their layout and a description of how they operate are as follows (see **PROGRAMMING RECORDS** for complete tables):

# FEATURES

## LEAST COST ROUTING (LCR), con t'd

### 1. Digit Comparison Table

Entry No.	Interval Allowed (max. 14 digits)		Time of Day Table Number (01-10)						
	From	To	Mon.	Tue.	Wed.	Thu.	Fri.	Sat.	Sun.
001	7232000	7233999	01	01	01	01	01	04	04
002	0	1	05	05	05	05	05	10	10
.									
100	<b>EMPTY</b>	<b>EMPTY</b>	-	-	-	-	-	-	-

Up to 100 interval entries may be made in the Digit Comparison Table (DCT). The dialed number is then compared to these interval(s) in sequential order, one digit at a time. There are three possibilities when the dialed digit is compared to the programmed interval:

1. A match is made • the DCT transfers to the programmed Time of Day List Table to compare the time of day the call is made to several programmed intervals.
2. No match is made • the dialed digits are compared to the next programmed interval.
3. The end of the DCT is reached (no more programmed intervals) • the system will select any available line and make the call, but will display 'LCR Unavailable' at the **keyset**.

For example, if you dial 723-3222 on the weekend, the interval for Entry no. 001 is satisfied and the DCT transfers the comparison to the Time of Day Table **#04**.

If the user begins a dialed number with a 0 or 1, for a long distance call, during the week, the interval for Entry no. 002 is satisfied and the DCT transfers the comparison to the Time of Day List Table **#05**.

- NOTES:**
1. A maximum of fourteen digits may be entered as the 'Interval Allowed'. This includes the digit 0-9 and a wild card digit ('X'), which matches all digits.
  2. The wild card digit ('X') is available if programming is done through Remote System Programming via a PC. If programming is done at a station, the wild card digit can be entered by pressing F-7-K
  3. Each 'from' interval digit must be less than or equal to its corresponding 'to' digit.

### 2. Time of Day Tables

Table 01

Entry	Time	Period	Line Pools Table
Entry Number (1-8)		Minute (00-59)	
1		00	
2		00	
3		00	
4			
5			
6			

# FEATURES

## FAST COST ROUTING, cont'd

e 02

Hour	Time Period (00-23)	Minute (00-59)	Line Pools Table Entry Number (1-8)
08		15	6
15		25	3
17		30	4

le 03

ble 10

e Time of Day Tables numbered 03 • 10 are identical to the first two tables shown above.

r example, in Time of Day Table #01, if a call occurs between 08:00 (a.m.) and 17:00 (5:00 p.m.), the  
 ye Pool will be selected from Line Pools Table Entry #1. If it occurs between 2300 (11:00 p.m., entry #3)  
 id 08:00 (a.m., entry #1), the Line Pool will be selected from Line Pools Table Entry #3.

**DTE:** There are ten Time of Day Tables, each with six entries. Each entry shows the start time of a differ-  
 ent time period. The time period ends at the next entry time.

### Line Pools Table

Entry No.	Pool Selection							
	Choice 1		Choice 2		Choice 3		Choice 4	
	Pool (N/1-8)	DMT No. (N/1-8)	Pool (N/1-8)	DMT No. (N/1-8)	Pool (N/1-8)	DMT No. (N/1-8)	Pool (N/1-8)	DMT No. (N/1-8)
1	1	6	2	7	3	8	4	1
2	5	2	6	3	7	4	8	5
8								

For example, if Line Pools Table Entry #1 is chosen by the Time of Day Table, then Pool 1 will be the first  
 choice to make the call from and the dialed number will be modified by the Digit Modification Table (DMT)  
 Entry #6. Pool 2 would be the second choice (in case all Pool 1 lines are in use) and the dialed number  
 would be modified by DMT Entry #7. The third and fourth pool choice act in a similar fashion.

---

# FEATURES

## LEAST COST ROUTING, cont'd

**NOTES:** 1. There are 8 entries in the Line Pools table.

2. DMT No. stands for Digit Modification Table Entry Number and refers to entries made in the next table.

### 4. Digit Modification Table

Entry No.	Number of Digits To Delete (0 - 12)	Digits To Insert 16 Digits Maximum (0 -9, Pause)
1	1	10288
2		
8		

For example, if the Line Pools Table selects DMT Entry #1, the first digit of the number will be deleted and replaced with the number 10288. This is useful in cases such as this one, where it is desirable to replace the first digit of a phone number, such as a 0 or 1 for long distance calls, by a long distance carrier's number.

**NOTES:** 1. There are 8 entries for the Digit Modification Table.

2. Digits are deleted from, and added to, the beginning of the telephone number dialed.

**DEFAULT:** 1. All LCR tables are empty.

2. LCR is disabled for all stations.

## LCR PROGRAMMING EXAMPLE

The following is a programming example for a hypothetical company.

The company has two types of lines: Public C.O. lines and WATS lines.

- Line 1 and Line 2 are Public C.O. Lines
- Line 3 and Line 4 are WATS Lines, with cheaper rates during business hours than regular long distance

The system administrator programmed Pool 1 to include Line 1 and Line 2 (C.O. lines) and Pool 2 to include Line 3 and Line 4 (WATS lines)

Next, the system administrator created a chart in order to show the pool preferences according to the week, time of day, and type of call.

# FEATURES

## LCR PROGRAMMING EXAMPLE, cont'd

Type of Number Dialed	Day(s) of the Week	Time of Day (24-Hour Mode)	Pool Preference Order
Long Distance	Monday - Friday	08:00 to 18:00	Pool 2, then Pool 1
Long Distance	Monday - Friday	18:00 to 08:00	Pool 1, then Pool 2
Long Distance	Saturday, Sunday	All Day	Pool 1, then Pool 2

In addition to the information recorded in the chart above, the following information was also recorded.

- There is no long distance access or carrier code for WATS lines, therefore no change needs to be made to the original dialed number when accessing those lines.
- For Public C.O. lines, an access code is used to access the long distance carrier desired. It is necessary to delete the first digit of the dialed number ('1') and add the access code to the beginning of the original dialed number.

	No. of Deleted Digits	Digits to Insert
For Pool 2	0	NONE
For Pool 1	1	10288

Finally, the system administrator outlined the present telephone system and calling needs, and this information was put into the LCR tables. Please see PROGRAMMING RECORDS, SECTION 8 for empty LCR tables which may be used to store your programming information.

### 1. Digit Comparison Table

Entry No.	Interval Allowed (max. 14 digits)		Time of Day Table Number (01-10)						
	From	To	Mon.	Tue.	Wed.	Thu.	Fri.	Sat.	Sun.
001	1X0X	1X1X	01	01	01	01	01	04	04
002	EMPTY	EMPTY	-	-	-	-	-	-	-
100	EMPTY	EMPTY	-	-	-	-	-	-	-

# FEATURES

## LCR PROGRAMMING EXAMPLE, cont'd

### 2. Time of Day Tables

Table 01

Entry No.	Time Period		Is T a b l e
	Hour (00-23)	Minute (00-59)	
1	08	00	
2	18	00	
3			
4			
5			
6			

Table 04

Entry No.	Time Period		Line PoolsTable
	Hour (00-23)	Minute (00-59)	
1	00	00	2
2	23	59	N
3			
4			
5			
6			

### 3. Line Pools Table

Entry No.	Pool Selection							
	Choice 1		Choice 2		Choice 3		Choice 4	
	Pool (N/1-8)	DMT No. (N/1-8)	Pool (N/1-8)	DMT No. (N/1-8)	Pool (N/1-8)	DMT No. (N/1-8)	Pool (N/1-8)	DMT No. (N/1-8)
1								
2	1	1	2	2				
3	2	2	1	1				
4								
5								
6								
7								
8								

# FEATURES

## LCR PROGRAMMING EXAMPLE, cont'd

### 4. Digit Modification Table

Entry No.	Number of Digits To Delete (0 - 12)	Digits To Insert 16 Digits Maximum (0 -9, Pause)
1	0	EMPTY
2	1	10288
8		

## LINE ASSIGNMENT

Each line may be selectively made available for specific stations to make outgoing calls.

### PROGRAMMING

See System Programming - Set/ Line Assignment (51.3).

- NOTES:**
1. A line that is available for outgoing calls at a station does not necessarily ring at the station on incoming calls. It only rings at a station if it is programmed to do so. See Ring Assignment.
  2. If a line is available to a station, the user may wish to program the line to be automatically selected when he lifts the handset or presses the **HANDSFREE** key. See Automatic Line Selection.
  3. At each Professional **keyset** to which lines are assigned, be sure to program corresponding Feature keys as Line keys or Pool keys. See Feature Key Programming.

**DEFAULT:** All lines are available to all stations.

## LINE POOL

The user may program one of his Feature keys to be a Line Pool key (see Feature Key Programming). There are eight Line Pools available to the user. When the key is pressed, the first available line from the line pool will be accessed.

If one of the lines in the pool is ringing, the green LED will flash quickly. Pressing the Line Pool key will answer the call.

### PROGRAMMING

To assign lines to line pools,  
see System Programming - Line/ Line Pool (5.2.4)

For lines in the line pool which must be made available to (assigned to) the station,  
see System Programming - Set/ Line Assignment (51.3)

---

# FEATURES

## LINE POOL, cont'd

In order to program a line to ring at a particular station,  
see System Programming ▪ Set/ Ring Assignment (51.4)

- NOTES:**
1. It is not allowed to set more than one key with the same line or pool number.
  2. If a station has a Line Pool key, and an individual Line key (when the Individual line is part of the pool):
    - a. Any incoming call will signal only the individual Line key.
    - b. Pressing the individual Line key will not affect the lamp indication of the Pool key.,

- DEFAULT:**
1. No Line Pool key is programmed.
  2. All lines belong to Pool One.

## LINE SIGNALING

The display of the Professional keyset will show which incoming lines are ringing.

### **PROGRAMMING**

To assign a line to ring at a particular station,  
see System Programming ▪ Set/ Ring Assignment (5.1.4)

## LONG DTMF TONES

Some carriers may provide certain services that require long duration DTMF tones to access the service. The LONG DTMF TONES feature allows the user to activate longer duration dialing. The duration of the tones returns to normal at the end of the call.

### **OPERATION**

Make a call. When you reach the point where long DTMF tones are required,  
Press: **F • 7 • 2**  
Any subsequent digits dialed will be sent out at the programmed long tone length.

### **PROGRAMMING**

See System Programming ▪ Call Handling/ Long Tones (5.3.6).

- NOTES:**
1. The DTMF duration for regular dialing is referred to as the "Tone Time". It is also programmat and is not to be confused with "Long DTMF Tones". See System Programming ▪ Call Handling/ Tone Duration (5.3.5).
  2. The Long DTMF Tone duration is programmable from 200 to 1500 milliseconds (ms), in 100 millisecond (ms) increments.
  3. The minimum interval between two long DTMF tones will be the same as the programmed ton duration (70 ms, 120 ms or 150 ms).

**DEFAULT:** Long Tone Duration time is 1400 ms.

---

# FEATURES

## LOOP BREAK DETECTION

Some central offices provide a loop break (absence or reversal of DC **voltage**) as a disconnect pulse after a party hangs up. If the system detects the loop break, it can take one of the following **actions**:

1. If the C.O. line call is connected to a Voice Mail port, the system will send a **disconnect** header to the voice mail port.
2. If the C.O. line call is on a **DISA** or External Call Forward line, the system will release both incoming and outgoing lines.
3. If Loop Break Detection is programmed, the system will drop held calls when a **C.O.** loop break signal is detected. See **HOLD ABANDON** for more details.

## **PROGRAMMING**

To enable Loop Break Detection and set the minimum pulse length the **system** will detect, see System Programming - Peripheral/ Loop Break Detection (5.6.7)

To program a Disconnect Header for Voice Mail, see System Programming - Peripheral/ Voice Mail (5.6.5)

- DEFAULT:**
1. Loop Break is enabled.
  2. Minimum pulse length is 350 milliseconds.

## LOUD BELL INTERFACE

A connection is supplied (on the DKS 55 option board) that can drive an external bell. It can be programmed to ring when any line, line pool, or station rings. It can be active during Day service, Night service, or **both**.

## **PROGRAMMING**

See System Programming - Peripheral/ Loud Bell Interface (5.6.3).

- DEFAULT:**
1. Service is disabled.
  2. Ringing is not selected for any line, line pool, or station.

## MANUAL LINE ACCESS

Eight of the feature keys on the Professional **keyset** (DKS 925, **935**), the nine feature keys and twelve DSS/SPD keys on the Professional **keyset** (DKS **930**), and the seven feature keys on the Associate Plus **keyset** (DKS 830) may be programmed as Line keys. The user may press any of those keys to access a line for an outgoing call, to answer an incoming call, or to retrieve a **held** call.

Additionally, any time the user Of an Associate or Professional **keyset** hears the intercom dial tone, he may press the digit 9 to access an available line.

---

# FEATURES

---

## MANUAL LINE ACCESS, *conf'd*

### PROGRAMMING

See *FEATURE KEY PROGRAMMING*.

### OPERATION

**Professional keyset:**

Press: a **Line** key to gain access to the line.

**Associate keyset:**

If no Line key is present or if a Line key is not programmed,

Press: **F - 0 - n** (where n is 1-6 - representing Lines 1-6).

---

## MESSAGEWAITING (*sending*)

A caller may leave a message at a Station at any time. The message may be a regular message from the system, a special message that is preprogrammed, or a message that the user writes (up to 16 characters). If the phone receiving the message is an Associate **keyset**, a "message waiting" indication (a slowly flashing Intercom LED) may be left on the set.

### OPERATION

**Professional keyset** only:

Press: **F - 9 - 6 - SN** (2-digit station number or DSS key)

Press: **SAVE** soft key

Or, if there is no answer during a call,

Press: **MSG** (message) soft key

Press: **REGULAR** soft key

The words 'Msg from set XX' will appear at the called station.

Or,

The calling party may select a special system message (common to all stations), or a private special message (available from that party's station only):

Press: **SPECIAL** soft key

Press: **NEXT** soft key repeatedly until the desired message appears.

Press: **SEND** soft key. The selected message will be sent.

When no answer is received on an intercom call to an Associate set,

Press: **MSG** soft key. The Associate set's Intercom LED will flash slowly to indicate a message waiting.

To cancel a message left at one station,

Press: **F - \* - 9 - 6 - SN** (2-digit station number),

Or,

Press: **F - \* - 9 - 6 - \*** to cancel all messages.

**Associate keyset:**

1. Setup: **F - 9 - 6 - SN**.

Or, during a call if there is no answer, press F96.

2. Cancel: **F - \* - 9 - 6 - SN** to cancel a message left at one station,

Or,

2. **F - \* - 9 - 6 - \*** to cancel all messages left at other stations.

---

# FEATURES

---

## MESSAGE WAITING (sending), cont'd

### PROGRAMMING: Private Messages

**Professional keyset** only:

Press: F ■ 9 ■ 6 ■ SN (station number of Professional keyset)

Press: **SAVE soft** key

Or, during a call, if there is no answer,

Press: MSG (message) soft key.

Press: **SPECIAL soft** key

Press: **NEXT** soft key repeatedly until the display shows "EMPTY", or until a previously programmed private message that you wish to change is displayed.

Press: **CHG** (change) soft key.

Enter a message using the same method as for programming user names. See System Programming Resource/ User Names (5.45).

- NOTES:
1. The system may have up to 24 messages waiting at one time.
  2. If the message waiting queue is full, the sending set will receive the message: "MW OVERFLOW (Professional keyset only) and hear a double beep (Professional and Associate keysets).
  3. The system provides five default programmed special messages that may be used by any station. Three of these messages may be changed by the system attendant. See System Programming Resource/ Messages (5.4.13).
  4. There are also two private messages for each station. The private messages are programmed by each station user.
  5. Each station may leave messages to more than one station.
  6. Each station may receive messages from more than one station, but will only store the last message from each station.
  7. Messages may not be left to Single Line Telephones or other equipment behind a DKS 50 Analog Adapter.

DEFAULT: The default messages are:

CALL BACK XX (XX is the calling station number)

URGENT XX

CALL OPERATOR

CALL HOME

VISITOR WAITING

EMPTY (Private message)

EMPTY (Private message)

---

## MESSAGE WAITING (answering)

When a regular message is left at your station by another party, you may have the system dial the party back for you, or delete the message.

When a special message is left (at a Professional keyset), you may read it or delete it.

# FEATURES

## MESSAGE WAITING (answering), cont'd

### OPERATION

#### Professional keyset:

To read a special message:  
When a message is present,  
Press: **SHOW** soft key

To see additional messages,  
Press: **MORE** soft key

To delete messages,  
Press: **DEL** soft key

To reply to a regular message,  
**Press: REPLY.** The station will call back the party that left the message.

#### Associate keyset:

To answer a message:  
Press: **ICM** key ▪ #. The system will call back the station that left the message.

If there is more than one message waiting, repeat the steps above, or press # if the first station does not answer.

To delete all messages received from other keysets,  
Press: **ICM** key ▪ \*

**NOTES:** 1. Messages may be left by other stations, or by a voice mail system. A user may choose to reply to specific messages, or all messages, with the choices listed:

To reply to messages left by:	Press:
a. Other stations only	F - 9 - 6
b. Voice Mail only	F - 9 - *
c. All messages	ICM key ▪ # (Associate keyset only)

- Messages from other keysets are removed when they are replied to or deleted, regardless of whether the original party is reached.
- Messages from Voice Mail are removed only when the Voice Mail unit sends a cancel code (F ▪ \* ▪ 9 ▪ 6 ▪ SN).
- The following indicators show that a message has been received:
  - Intercom LED is flickering ▪ message waiting and Voice Mail messages.
  - If a Message Waiting feature key is programmed (F ▪ 9 ▪ 6), the LED of the key will flash when a message from a station is waiting.
  - If a Voice Mail feature key is programmed (F - 9 - \*), the LED of the key will flash slowly only when a message is received from Voice Mail.

---

## FEATURES

### **MESSAGE WAITING (advisory message)**

The Professional keyset user may leave a message on the LCD of his phone when he is away from the office. Any Professional keyset that calls him will receive this advisory message. The message may be selected from five system messages (available to all Professional keysets), or from two private messages that the user may program himself.

### **PROGRAMMING (Professional keyset only)**

Press: F ■ 9 ■ 0

Press: **NEXT soft** key until the desired advisory message appears.

Press: **SAVE** soft key. The message will appear on the LCD.

To Cancel:

Press: **OFF soft** key

To write a private message,

Press: F ■ 9 ■ 0

Press: **NEXT soft** key until the word "EMPTY" or a private message that you wish to change appears.

Enter a message using the same method as for programming user names. See System Programming - Resource/ User Names (5.4.5).

- NOTES:**
1. The system provides five default programmed messages that may be used by any station. These messages may be changed by the system attendant. See System Programming - Resource/ Messages (5.4.13).
  2. There are also two private messages for each station. The private messages are programmed by each station user.

DEFAULT: The default advisory messages are:

AT LUNCH

BE BACK SOON

IN A MEETING

OUT OF OFFICE

ON VACATION

EMPTY (Private message)

EMPTY (Private message).

---

### **MIXED DIALING (Pulse to Tone conversion)**

This feature allows the user to change from Pulse mode dialing to Tone mode.

#### OPERATION

When the line you are dialing on is set to Pulse mode,

Press: **\***. Subsequent dialed digits will be in Tone mode.

If the user is on a Professional keyset, the **\*** will show as the letter "T" (Tone) in the display.

---

## FEATURES

### **MIXED DIALING (Pulse to Tone conversion), cont'd**

**NOTES:**1 .Conversion from Pulse to Tone is allowed, but not from Tone to Pulse.

2. If a mixed number is stored in memory, or redialed, the stored number will **switch** from Pulse to Tone the same way, as long as it is dialed on a Pulse line.

### **MODEM SETUP STRING**

As part of the set up of Remote Programming through a modem, a user may send a setup string out of the serial port labeled 'MODEM'. This is used to set up a modem attached to the port to enable it to receive calls. See the REMOTE PROGRAMMING section of this manual.

#### OPERATION

Press: F 7 8. The command string will show on the display.  
Press: SEND soft key to send the command string to the modem.

#### PROGRAMMING

To change the modem setup string,  
see System Programming - Peripheral/ Modem Setup (5.6.6).

**NOTE:** The command header 'AT' is automatically appended to the beginning of the string. It does not show on the display, but is sent automatically.

**DEFAULT:** The default command string is: **AT&FE0&Q0S0=3.**

### **MUSIC ON HOLD**

Music may be played to any party on hold, if an external music source is connected via the optional DKS board.

#### OPERATION

When a call is placed on hold, the music will play to the held party.

**NOTE:** The volume of the music is adjustable. See the DKS 308XL installation instructions.

### **MUTE**

The Mute feature allows a user to disable transmission of his voice, while still being able to listen to the other party.

#### OPERATION

Professional **keyset** only:  
When on a call,  
Press: MUTE soft key

To cancel Mute,  
Press: MUTE soft key

---

# FEATURES

## **MUTE, cont'd**

- NOTES:** 1. Only the transmission path from the originating station is blocked when Mute is enabled.
2. The Mute function is disabled if a call is terminated.

**DEFAULT:** Mute is disabled.

---

## **OFF HOOK VOICE ANNOUNCE**

Any station may talk to a **Professional keyset** that is busy, but not in handsfree mode. The voice will come out the called party's speaker.

### **OPERATION**

#### **Professional keyset:**

When hearing a busy signal:

**Press: OHVA** (Off Hook Voice Announce) soft key. After you hear a beep, speak.

If the called party rejects the OHVA, the caller's display will say "OHVA REJECTED" and a double beep will be heard.

#### **Associate keyset:**

When hearing a busy signal,

Press: **F • 5 • 6**

If rejected, a double beep will be heard

To reject an OHVA from a **Professional keyset**,

Press: **REJECT** soft key

- NOTES:** 1. The called party may speak to the new calling party via speakerphone while the original call is in progress through the handset.
2. The OHVA may be released by pressing any key at the called party.

---

## **ON HOOK DIALING**

Without lifting the handset, the user can press an Intercom or a Line key to make an outgoing call directly. The dialing and called party may be heard through the speaker.

### **OPERATION**

#### **Professional keyset:**

Press: **Line** key

Or,

Press: **INTERCOM** key

Dial the number.

To end call,

Press: **RLS** (Release) key

---

# FEATURES

---

## **ON HOOK DIALING, *conf'd***

### **Associate keyset:**

The Associate may use On hook dialing for Last Number Redial, Saved Number Redial, and Intercom or Line Calls.

Press: **REDIAL** key

Or,

Press: **F - 5 - 1** (for Saved Number Redial)

Or,

Press: **INTERCOM** key - SN (station number)

Or,

Press: **INTERCOM - 9 -** outside phone number.

Or,

Press: **F - 0 - n** (where n is 1-6)

When the party answers, lift handset.

---

## **PAGING**

Any set may initiate a page. It will be heard through other station's speakers, or through the external speaker if the system is so equipped. There are five types of pages:

1. Voice Page (makes a voice call to one station)
2. Page All (page is heard through external speaker and at all stations)
3. Page Internal (page is heard at all stations)
4. Page External (page is heard through external speaker)
5. Page Group (page is heard at stations that belong to a particular group).

In addition, any station may answer the paging party automatically, without knowing the number of the paging party. See *PAGING ANSWER*.

## **OPERATION**

For each of the following options, the user may speak after he hears the beep.

### **Professional keyset:**

Press: **F - 5 - 0**

Select: **VOICE**, **ALL**, or **NEXT Soft** key

If **VOICE** is selected, enter a station number.

If **VOICE** or **ALL** is selected, a beep will be heard, and the user may speak.

If **NEXT** is selected, then three options appear.

Select: **INT** (internal), **EXT** (external), or **GROUP soft** key.

If **GROUP** is selected, then

Press: a digit from 1 to 8 (group number you wish to page).

---

# FEATURES

---

## PAGING, con t'd

### Associate keyset:

Press: **F - 5 - 0 - 0 - SN** (station number) for VOICE PAGE

Press: **F - 5 - 0 - 1** to PAGE ALL

Press: **F - 5 - 0 - 2** to PAGE INTERNAL

Press: **F - 5 - 0 - 3** to PAGE EXTERNAL

Press: **F - 5 - 0 - 4 - GN** (group number) to PAGE GROUP

**NOTES:**1 .External paging requires a DKS 55 option board, and a customer-supplied paging amplifier and speakers.

2. If paging fails due to no idle sets, or because the external amplifier is already busy, the display will show "PAGE DENIED" (Professional keyset) and a double **beep will be heard**.

3.If the paging party wishes to be called back, he should remain off hook to wait for a page answer.  
See *Paging Answer*,

4. When a Voice Call is made to a Professional keyset, the called party's voice can automatically be heard by the caller, unless the called party has programmed Voice Call off. See **VOICE CALL ENABLE**.

5. Another method of making a Voice Page is to dial a station number, then press **\***.

---

## PAGING ANSWER

While the paging party is still off hook, any station may answer the page. It is not necessary to know the station number.

### OPERATION

To answer a page (from any station):

Press: **F - 5 - 9**

Connection to the paging party will be made.

**NOTE:** If PAGE GROUP is selected, only the stations in that group may answer the page.

---

## PAUSE

A pause of programmable length may be entered when dialing.

### OPERATION

Press: **F - 7 - 0**

### PROGRAMMING

See System Programming - Call Handling/ Pause Time (5.3.3).

---

# FEATURES

## **PAUSE, cont'd**

- NOTES: 1. The pause may be stored in Last Number Redial, Speed Dial, or Saved Number Redial. If it will appear as the letter "P" on the Professional set's display.
2. The Pause Time is selectable from 1.5, 2.0, 3.5 or 5 seconds.

DEFAULT: Pause time is 2 seconds.

## **PBX COMPATIBILITY**

If a system (or line) is behind a PBX or **Centrex**, line access codes may be programmed into the system for automatic dialing. If the user manually dials the access code, the system will automatically put a one-second pause after the access code.

### OPERATION

Dial the access code (one or two digits).

Dial the number desired. The system will automatically put a fixed length pause after the access code (to wait for a dial tone).

### PROGRAMMING

To program the access code,  
see System Programming ▀ Call Handling/ PBX Code (5.3.4)

To select whether a line is behind a PBX or a C.O.,  
see System Programming ▀ Line/ Line Type (5.2.3)

- NOTES: 1. PBX access codes may be one or two digits.
2. An automatic **pause** after an access code will be added to each individual line that is programmed to work behind a PBX, and there will be no automatic pause on lines that are **individually** programmed behind a C.O. line.

- DEFAULT: 1. All lines are connected behind a Central Office.
2. The PBX access code is the single digit "9".

## **POWER FAILURE TRANSFER**

In the event of a power failure, Lines 1 and 4 will be switched to a special port on the KSU connector. A line-powered analog phone connected to those ports will be able to work during the power failure.

## **PRIVACY**

All calls normally have privacy and may not be intruded upon. However, paging or Off Hook Voice Announcements (OHVA) may be made to a set while its handset is in use. The page or **OHVA** will come through the speaker of the set.

---

# FEATURES

## **PRIVACY, cont'd**

Normally, if a user is on a C.O. line, it is regarded as 'busy' and other stations may not access the same line. The user of the line may initiate a conference call to allow other stations to join the line.

If Privacy is released, a second or third user may join a call simply by accessing the same line. This is similar to picking up an extension on your home phone to join a conversation.

## **OPERATION**

To join a call in progress on a CO. line:

### **Professional keyset:**

Press: a **LINE** key

### **Associate keyset:**

Press: F - 0 - **LN**, (where LN is the single digit line number 1-6).

## **PROGRAMMING**

See System Programming - Line/ Privacy (52.6).

NOTES: 1. To release Privacy on a line, 'PRIVACY' must be set to 'N' in system programming. In addition, the line must not be assigned as 'PRIVATE TO' any station. See **PRIVATE LINE**.

2. Up to three stations may participate on a line call.

DEFAULT: PRIVACY is set to 'YES'.

## **PRIVATE LINE**

Any line may be programmed as private for one station. Only that station can make outgoing calls on the line, and incoming calls on the line will only ring at that station.

## **PROGRAMMING**

See System Programming - Line/ Private Line (5.2.5).

NOTES: 1. An incoming call on a private line will only ring the private station, regardless of other ring assignments. In other words, private line programming overrides the ring assignment.

2. Private line assignment automatically changes the programming of ring and line assignment for all stations. The line will become unavailable for all the other stations.

3. When private line assignment is canceled, the line will become available to all stations. The ring will only be assigned to the attendant.

4. If the line assignment of the private line is changed to 'N' (No) for the private station, the private line assignment will be canceled. In this case the line assignment remains 'N' at other stations.

5. An incoming call on a private line may not be picked up by any other station.

DEFAULT: No private lines are assigned.

---

# FEATURES

## **RECALL**

If a transferred line call is not answered within a programmable number of rings, it will ring again (recall) at the original station.

### **OPERATION**

See *TRANSFER*.

### **PROGRAMMING**

See System Programming • Call Handling/ Recall Rings (5.3.2).

NOTES: 1. Transferred intercom calls will not recall to the originator.

2. The number of rings before transfer recall is programmable from 1 to 8

3. If a transferred line call is not answered when it recalls to the original station, it will then ring at the attendant. If it is not answered by the attendant after the programmed number of rings, it will remain on hold at the original station.

DEFAULT: 3 Rings before recall.

## **RELEASE**

Pressing the RLS (Release) key will drop the call you are on.

Pressing the RLS (Release) key will end or abandon any feature programming.

## **REMOTE PROGRAMMING**

A personal computer may be connected to the system through an RS 232 port. The port is part of a DKS 5 option board. The PC provides a simplified method of making extensive changes to the system programming. Access may also be made remotely, through the public telephone network, if a standard modem is connected to the RS 232 port, and to a PC in a remote location.

A station user may change the system programming on the PC, then download the new data base into the system. The present system may also be uploaded to the PC and saved for backup.

### **OPERATION**

See REMOTE SYSTEM PROGRAMMING section.

## **RING ASSIGNMENT**

Each station may ring on incoming calls for selected lines. The lines which ring at a station during the 'Day' or 'Night' service modes can be chosen separately.

### **PROGRAMMING**

See System Programming • Set/ Ring Assignment (5.1.4).

---

# FEATURES

---

## ***RING ASSIGNMENT, cont'd***

NOTE: If a line rings at a station, that station may answer the call on that line. It does not mean the station can make an outgoing call on the line. A station may do that only if the line is assigned to that station (see L/NE ASSIGNMENT).

DEFAULT: All lines ring at station 10 Only (attendant for Zone 1) during the 'Day' and 'Night' service modes.

---

## ***RINGING (in use)***

When a user is on a call, other incoming calls may still ring at that station. The system may be programmed to provide either a beep in the user's audio path to signal a ring or it may also be programmed so a regular ring is heard through the keyset speaker.

## **PROGRAMMING**

See System Programming • Call Handling/ Ring on Talk (5.3.16).

DEFAULT: Ring on Talk is 'NO' (a beep in the audio path will be heard instead).

---

## ***RINGING LINE PREFERENCE***

If a station is ringing with more than one call at once, calls will be answered according to the following priority. The handset may be lifted or the HANDSFREE key pressed:

1. Incoming Line Call
2. Recalled Line Call
3. Transferred Line Call
4. Camped Line Call
5. Call Again Intercom Call
6. Incoming Intercom Call

---

## ***SAVED NUMBER REDIAL***

A user may temporarily store a dialed number into a specified memory location. Later, after making other calls, the user may access the previously stored number. It will automatically be dialed on the same line it was originally dialed on.

## **OPERATION**

### **Professional keyset:**

Access an outside line and dial a number. To store the number dialed,

Press: **F - 5 - 1**

The number is now stored.

---

## FEATURES

### ***SAVED NUMBER REDIAL, cont'd***

To call the saved number,

Press: **F - 5 - 1**

The same line will be selected, and the number dialed.

If the line is not available, the display will inform you the line is busy. To dial on another line,  
Press: **AUTO LN** (Automatic Line Select) soft key

Or,

Press: **CAMP** soft key to camp on the busy line.

#### **Associate keyset:**

Access an outside line and dial a number. To store the number dialed,

Press: **F - 5 - 1**

The number is now stored.

To call the saved number,

Press: **F - 5 - 1**

The same line will be selected and the number dialed.

If the line is not available, you will hear a busy tone.

To automatically select another idle line,

Press: **\***

To camp on the busy line,

Press: **#**

- NOTES:**
1. A pause is automatically inserted before dialing the Saved Number Redial (SNR), allowing to obtain a dial tone.
  2. If the SNR is not stored and **F51** is pressed, the system will display "**SNR EMPTY**" on the Professional **keyset** and will give a double beep on both Professional and Associate keyset
  3. Another way to use SNR is to access a specific line first, by pressing a Line key, lifting the handset or pressing the **HANDSFREE** key. Then press **F51**, and the saved number will be dialed on the line selected, instead of the line it was originally dialed on.
  4. Up to 31 digits may be saved.

**DEFAULT:** The SNR buffer of each station is empty.

---

### **SHIFT**

The special **SHIFT** key on the Professional **keyset** has two uses:

1. Pressing **SHIFT**, so that the SHIFT LED lights, allows access to the second page for dual function keys. If the LED is dark, access is to the first page. The dual function keys include the Direct Station Select/System Speed Dial keys.
2. When programming the system, the SHIFT key acts as an 'Exit' function. The current programming step is abandoned, and the programming moves back to the next higher step or category.

---

# FEATURES

## ***SHIFT, cont'd***

### **OPERATION**

For example, to call station 10,  
Press: INTERCOM key + DSS key **1**

But to call station 22,  
Press: SHIFT + INTERCOM + DSS key **1**

NOTE: When used with the **DSS/SPD** keys, the SHIFT key is a toggle function. **It** remains on or off until the key is pressed again.

---

## ***SIMULTANEOUS VOICE/DATA CAPABILITY***

The DKS 935 Professional **keyset** is equipped with a data module to allow it to interface with any data de- &e, such as a personal computer. If such a device is Connected, the user may activate data communication **with** a remote terminal at another station while a voice call between them is in progress.

### **OPERATION** (Professional Plus **keyset** only)

When on a call, you may  
Press: DATA key  
Press: SN (**2-digit** station number) that you wish to connect your data port to.

### PROGRAMMING

To program a key as the DATA key, see *Feature Key Programming*.

To set the data rate for communication,  
Press: F - 7 - 9  
Press: CHG soft key until desired rate is displayed  
Press: RLS key

NOTE: The data call will not affect any voice calls, since they are on different channels in the system.

---

## ***SOFT KEYS***

Each Professional **keyset** has three soft keys located under the LCD display. When pressed, each key performs the function shown on the display above it.

---

## ***SPEED DIALING (STATION)***

Each station may store up to 24 speed dial numbers. On the Professional **keyset**, these numbers are accessible through the **DSS/SPD** keys. On the Associate **keyset** the access codes can be dialed.

---

# FEATURES

## ***SPEED DIALING (STATION), cont'd***

### OPERATION

#### **Professional keyset:**

Press: SPD key (or **SHIFT + SPD** key). The station will access a line and dial the number programmed to that key.

Or,

If DSS has priority (see **DSS/SPD Priority**),

Access a line by pressing a Line key and lifting the handset, or press the **HANDSFREE** key.

Press: **SPD** key (or **SHIFT + SPD key**)

To make a call using the SPD access codes:

#### **Professional keyset:**

Press: **LINE** key

Press: **F - 1 - SPD Code (01-24)**

#### **Associate keyset:**

Access a line, then

Press: **F - 1 - SPD Code (01-24)**

### PROGRAMMING

#### **Professional keyset:**

Press: **F - 1**

Press: SPD Code (**01-24**) or **SPD** key that you wish to review or change,

Press: **SHOW soft** key

The number stored will be displayed.

Press: **CHG (Change)** soft key

Enter: new number (use **BKSP** soft key to backspace if necessary).

Press: **SAVE soft** key

To cancel, after pressing the **CHG** soft key,

Press: **SAVE** (without entering a new number)

#### **Associate keyset:**

Press: **F - 1 - SPD Code (01-24) - telephone number - HOLD** key

To cancel,

Press: **F - 1 - SPD Code (01-24) - HOLD** key

NOTES: 1. Each station has 24 private speed dial locations available. They are numbered 01 to 24.

2. Three special codes may also be programmed, in addition to regular digits. These are 'Pause' (P), 'Flash' (F), and 'SPD Chain' (@). Their access codes are:

Pause - **F70**

Flash - **F3**

SPD Chain - **F1**

---

## FEATURES

---

### SPEED DIALING (STATION), cont 'd

#### NOTES, cont'd

3. For chain dialing, enter SPD Code after **F1**. For example, if you wish to store a number that is larger than the 16 digits allowed by one SPD location, it is **possible to chain memory locations** together, such as locations 21 and 22:

In location 21,  
Press: **F - 1 - 2 - 1**  
Press: **SHOW soft key**  
**Press: CHG soft key**  
Press: XXXXXXXXX (a phone number of up to 13 digits)  
Press: **F - 1 - 2 - 2**  
**Press: SAVE soft key**

**When** location 21 is accessed, its contents will be dialed, followed by the contents of location 22.

4. If in Tone mode, **'\*'** and **'#'** may be stored, and will be dialed as entered. In Pulse mode, **'\*'** will switch to Tone mode, and **'#'** will be ignored.

**DEFAULT:**

1. All speed dial locations are empty.
2. SPD has priority.

---

### SPEED DIALING (SYSTEM)

The system may have up to 74 numbers stored for use by all stations. These numbers may be recalled the same way as recalling station speed dial numbers (see **SPEED DIALING [STATION]**). They are stored in locations 25-98.

#### OPERATION

##### Professional keyset:

Access a line by **pressing** a Line key and lifting the handset, or press the **HANDSFREE** key.

Press: **F - 1**

Press: **2-digit SPD Code (25-98)**

##### Associate keyset:

Access a line, then

Press: **F - 1 - SPD Code (25-98)**

#### PROGRAMMING

See System Programming - Resource/ System Speed Dialing (54.6).

**NOTE:** Station speed dial numbers are stored in locations 01-24. System speed dial locations are 25-98.

**DEFAULT:** All Speed Dial locations are empty.

---

# FEATURES

## **STATION FEATURE STATUS CHECK**

The Professional **keyset** can use this function to check how the station is programmed for certain features, and to see what is in the Last Number Redial and Saved Number Redial buffers.

### **OPERATION**

Press: **F - # - 8**. The display will show the contents of the Last Number Redial (LNR) buffer.

Press: **NEXT** soft key repeatedly.

The display will show the following items in order:

LAST NUMBER REDIAL (LNR) BUFFER CONTENTS  
STORED NUMBER **REDIAL** (SNR) BUFFER CONTENTS  
DAY CLASS OF SERVICE (COS) (0-7)  
NIGHT COS (0-7)  
AUTO HOLD (ON/OFF)  
SET UNLOCKED/LOCKED  
VOICE CALL (ON/OFF)  
DATA RATE (**2400/4800/9600/19200**)  
LCR (DISABLE/ENABLE)

**NOTE:** To exit the feature at any time, press **RLS** (release) key.

**DEFAULT:** The default status of the features checked by this function are:

LNR	Empty
SNR	Empty
DAY COS	0
NIGHT COS	0
AUTO HOLD	On
SET	Unlocked
VOICE CALL	On
DATA RATE	9600
LCR	Disabled

---

## **STATION LOCK (and PASSWORD CHANGE)**

When a station user is away from his office, he can lock his phone so that no outgoing or incoming line c are allowed, An exception is-that an emergency call (911) may still be made on Professional **keysets** by pressing any Line key, **then** a soft key.

The set must be unlocked with a password. The password may be changed by the station user.

### **OPERATION**

**Professional keyset:**

Press: **F - 9 - 7**

Enter: **4digit station password** (use BKSP [backspace] soft key if necessary)

Press: SHOW soft key

Select: **YES** soft key to lock keyset,

Or,

Select: NO soft key to leave **keyset** unlocked.

---

# FEATURES

---

## STATION LOCK (and PASSWORD CHANGE)

To reach Emergency 911 from a locked Professional set:  
Press: **LINE** key, the words "EMERGENCY 911" will be displayed.  
Press: Any soft key. After a pause, the digits 911 will dial out.

### Associate keyset:

To lock keyset,

Press: **F - 9 • 7 • PSWD (4 digits) - #**

To unlock keyset,

Press: **F - 9 • 7 • PSWD (4 digits) • \***

## PROGRAMMING

### Professional keyset:

To change password,

Press: **F - 9 - 7**

Enter: **4digit station password**

Press: **SHOW** soft key

Press: **PSWD** soft key

Enter: **New Password (4 digits)**

Press: **SAVE** soft key

### Associate keyset:

To change the password,

Press: **F - 9 - 7 • OLD PSWD • NEW PSWD (4 digits)**

**NOTES:** 1. No **outgoing** line calls may be made and no incoming line calls answered from a locked set. Calls may not be transferred to a locked set.

2. **Intercom** calls may still be made from and to the locked set,

3. If a user forgets his password, it may be checked in the system database. See System Programming • Resource/ User Password (5.4.12).

**DEFAULT:** All stations are unlocked.

---

## STATION MESSAGE DETAIL RECORDING (SMDR)

A serial printer or personal computer may be connected to the KSU via the DKS 55 option board. A record of all outside calls will be printed. The record shows the length of the calls, the number dialed, an account number if assigned, and other details.

## OPERATION

When an outside call is terminated, a record will be stored in the KSU. As soon as a printer is ready on the port, the record will be printed.

---

# FEATURES

---

## STATION MESSAGE DETAIL RECORDING (SMDR), *cont'd*

### PROGRAMMING

To select whether the Account Code is recorded, and whether incoming calls (in addition to outgoing calls) are recorded,

see System Programming • Peripheral/ SMDR Output (56.1)

To select the SMDR data rate,

see System Programming • Peripheral/ RS232C Data Rate (56.2).

**NOTES:** 1. Up to 200 calls may be stored in the KSU before printing.

2. An example of the output format is:

SET	LN	DGT DIALED	DATE	TIME	DURATION	ACCOUNT
10	3	7185551212	06/06	13:30:10	00:01:06	721470

The column numbers of the first digit of each field are:

SET = 1	DATE = 35	ACCOUNT = 60
LN = 11	TIME = 41	
DGT DIALED = 16	DURATION = 50	

3. The Time and Duration format is HH:MM:SS, where

HH = Hours  
MM = Minutes  
SS = Seconds,

4. Data field description:

**SET:** Station number (2 digits) or name if programmed (up to 7 characters)

**LN:** Line number, 2 digits from 1 to 6

**DGT DIALED:** Phone number for outgoing calls, up to 16 digits. The field is blank for incoming calls.

**DATE:** Date the call is initiated

**TIME:** Time the call is initiated

**DURATION:** Length of conversation

**ACCOUNT:** Account code for billing purposes, 8 digits maximum

5. The call duration begins 10 seconds after the station is taken off hook.

**DEFAULT:** 1. The transmission rate of the SMDR RS 232 port is 9600 bps.

2. Account codes (if entered) will be printed.

3. Incoming calls (in addition to outgoing calls) will be recorded.

---

# FEATURES

## STATION NUMBERING PLAN

The stations are numbered from 10 to 33 for a 12 X 24 system. If analog adapters are used so that two analog phones are connected to one port, the second analog phone will have a number from 58 to 81. Stations 10 and 58 would be connected to port 10, stations 11 and 59 to port 11, etc..

## PROGRAMMING

Stations may be renumbered to any unoccupied number from 10 to 81.

See System Programming - Set/ Set Position (51.7)

**NOTES:** 1. Station numbers 10 to 33 and 58 to 81 are Considered 'occupied' in default mode, even if there are no stations in the system with those numbers.

For example, if the system actually has 8 stations installed, numbered 10 to 17, then numbers 18 to 33 and 58 to 81 are still considered 'occupied' by the system.

To change station number 10 to number 30 would therefore require the following steps:

a. In System Programming - Set/ Set Position (5.1.7), change set number 30 to an unoccupied number (34 to 57).

For example, change set 30 to 34. This makes position 30 available.

b. Change set number 10 to 30.

Now station 10 will be unoccupied, station 30 will be occupied, and station 34 will be occupied.

2. Station numbers 82 to 89 are reserved for Hunt Groups.

**DEFAULT:** 1. 10 to 33 (B1 channel) are occupied.  
2. 58 to 81 (B2 channel) are occupied.  
3. B1 and B2 refer to the two communication paths available between each port and the KSU.

## SYSTEM ALARM

Up to eight system alarm times may be programmed in the KSU. When a system alarm time is reached, the system will play background music to all idle sets for one minute. This requires a music source.

## PROGRAMMING:

See System Programming - Resource/ System Alarm (54.1).

**DEFAULT:** No system alarms are programmed.

---

# FEATURES

---

## SYSTEM SERVICE MODE

The system may be set up to operate differently at night than during the day. The following System programmed functions may be programmed to work differently at night:

<b>DISA</b>	Loud Bell
External Call Forward	Ring Assignment
Hunt Group Answer	Set Class of Service
Least Cost Routing	Toll Restriction
Line Class of Service	

In System Programming, a selection may be made to put the system in Day mode, Night mode, or Time mode. In Time mode, the system switches automatically to Night mode at the Night Start time, and back to Day mode at the Night End time.

### PROGRAMMING

The time periods defined as night and day may be programmed.  
See System Programming ▪ Resource/ Night Service (5.4.4)

To assign attendants for either zone,  
see System Programming ▪ Resource/ Attendant (5.4.2)

To select the System Service Mode (Day, Night, or Time),  
see System Programming ▪ Resource/ System Service Mode (5.4.3)

### OPERATION

An attendant may change the System Service Mode:

Press: F ▪ # ▪ 0 (at the attendant station only)

Press: the CHG soft key until the desired service mode appears (Day, Night, or Time)

Press: the RLS key

NOTE: To create a 'Night Service Station', change Night Ring to 'Yes' for each desired C.O. line(s). See System Programming ▪ Set/ Ring Assignment (5.1.4).

DEFAULT: 1. System is in the Time mode.

2. No Night Start or Night End times are programmed.

---

## SYSTEM TIME

The KSU has a clock to provide the time of day for display on the keysets, and tracking of system service mode and alarm clock settings.

The clock may be displayed in 12-hour mode, with AM and PM indications, or in 24-hour mode, See *HOLD MODE SELECTION*.

# FEATURES

## SYSTEM TIME, cont'd

### PROGRAMMING

To set the time,  
see System Programming - Resource/ System Time (5.4.9)

To select 12- or 24-hour mode,  
see System Programming - Resource/ Hour Mode Selection (5.4.14)

DEFAULT: System time is displayed in **12-hour** mode.

## TOLL RESTRICTION

Toll restriction is used **to** prevent stations **from** dialing certain telephone numbers or **types of calls to save** unnecessary expense. A **station** may be assigned a Class of Service (COS) from **0** to **7**.

Each COS may have up to 50 restrictions associated.

Each COS may also have up to 20 exceptions to the restrictions.

For example, station 10 may be assigned to COS 2. COS 2 may be restricted for (not allowed to dial) any **long distance calls** that begin with the digit "1" followed by any other **digits** (since "1" is the **digit** for **long distance dialing**). However, an exception may be made to allow calls **beginning** with 1-800, since **800** calls do not cost any money.

So if the station's COS is 2, then the restriction "1" would be assigned to COS 2, and the **exception "1-800"** would also be assigned to COS 2.

Each station has a DAY COS and a NIGHT COS, so different restrictions **may be applied during day or** night service modes.

Also, each line has a day and night COS, so that all calls on a particular line **may be subject to certain restrictions**.

The structure of the restriction table:

ENTRY	RESTRICT NUMBER (8 DIGITS)	STATION COS		LINE COS	
		DAY	NIGHT	DAY	NIGHT
		0 ----- 7	0 ----- 7	0 ----- 7	0 ----- 7
01	XXXXXXXX	N ---- N	N ----- N	N ----- N	N ----- N
02					
50		N mm--- N	N ----- N	N ---- N	N ----- N

# FEATURES

## **TOLL RESTRICTION, con t'd**

The structure of the exception table:

ENTRY	EXCEPTION NUMBER (14 DIGITS)	STATION COS		LINE COS	
		DAY	NIGHT	DAY	NIGHT
		0 ----- 7 - - - - 7		0 ----- 7	0 ----- 7
01	XXX...XXXX	<b>N ----- N</b>	<b>N ----- N</b>	<b>N ----- N</b>	<b>N ----- N</b>
02					
20	XXX...XXXX	<b>N ----- N</b>	<b>N ----- N</b>	<b>N ----- N</b>	<b>N ----- N</b>

NOTES: 1. There may be up to **50** restrictions.

2. There may be up to **20** exceptions.
3. Restrictions may be up to **8** digits in length, and may include the digits 0-9, and \* ( \* is a "wild card" digit which stands for any digit).
4. Exceptions may be up to **14** digits in length, and may include the digits 0-9, and \* ( \* is a "wild card" digit which stands for any digit).
5. Each call will be checked against all the restrictions and exceptions that are programmed for applicable COS.
6. The system will **first** check if a dialed call matches any entries in the restriction table. If no matches are found, the call is not restricted. If any matches are found, the system will check to see if the **restrictions** are Set to "YES" for the applicable set and line COS. If so, the system will check the exception table.

When checking the exception table, if the dialed number can be matched with an entry, and the COS programming for that entry is set to "YES" for the applicable set or line COS, then the call will be allowed. Otherwise, the call will be restricted.

## OPERATION

When the user tries to dial a call that is restricted, the station will return to idle condition and an error beep will be heard. The beep will stop when the user performs another action, such as pressing a Line key or hanging up.

---

# FEATURES

## TOLL RESTRICTIONS, cont'd

### PROGRAMMING

To program the restriction and exception tables,  
see System Programming • Restriction/ Toll Restriction (5.51)

To assign a Class of Service (COS) to a station,  
see System Programming • **Set/** Day Class (COS) (5.1 .1) or Night Class (COS) (5.1.2)

To assign a Class of **Service** (COS) to a line,  
see System Programming • Line/ Day Class, Night Class (COS)(5.2.1)

DEFAULT: All stations and lines may dial **any** outgoing number, since they are assigned to COS 0. The following restrictions are programmed into COS 1, 2, and 3.

### TOLL RESTRICTION DEFAULTS

ENTRY	RESTRICTION	STATION		LINE	
		DAY COS	NIGHT COS	DAY COS	NIGHT COS
01	1 900	1	1	1	1
02	1	2, 3	2, 3	2, 3	2, 3
03	0	2, 3	2, 3	2, 3	2, 3
04	411	3	3	3	3
05	976	3	3	3	3
06	540	3	3	3	3

## TONE DURATION

The DTMF tone duration may be selected from 70, 120, or 150 ms.

### Programming

See System Programming • Call Handling/ Tone Time (5.35).

- NOTES: 1. The inter-digit interval of numbers dialed from memory will be the same as the tone time selected.
2. The tone duration for end to end signaling, for voice mail applications, is programmable. See *VOICE MAIL*.

DEFAULT: 120 ms

---

# FEATURES

## TRANSFER

A station may transfer a call to another station. The basic procedure is to put the first call on hold, call another station, then hang up.

### OPERATION

#### **Professional keyset:**

**When** on a *line* or intercom call,

Press: XFR (transfer) soft button

Press: **STATION NUMBER** (2 digits) you want to transfer the **call** to

Hang up, or wait for the new **station** to answer, announce the transfer, then hang up.

#### **Associate keyset:**

**When** on a line call,

Press: **INTERCOM key**

**Press: STATION NUMBER** (2 digits) **you** want to transfer the call to

Hang up or wait for the new station to answer, announce the transfer, then hang up.

### PROGRAMMING

The number of unanswered rings before a transferred call will recall the originating set or the attendant is programmable from 1 to 8 rings (where each ring is approximately 6 seconds). See System Programming ■ Call Handling/ Recall Rings (5.3.2).

**NOTES:** 1. If Automatic Hold is disabled on an Associate **keyset**, the user must first,

Press: **HOLD** key, then

Press: **INTERCOM** key

to access an Intercom dial tone and make the second call.

2. **The DSS keys** may be used to enter a station number instead of entering the 2 digits when the Intercom dial tone is heard.
3. **Professional keyset users** may manually transfer calls (without using the XFR soft key) by placing the call on hold and dialing another station.
4. **If a line call is being transferred, and the station it is being transferred to does not answer within the programmed recall rings, the held call will recall (ring at) the original station. If the original station does not answer within the programmed recall rings, the held call will recall the attendant. If the attendant does not answer, the call will remain on hold at the original station.**
5. **Transferred** Intercom calls will not recall the originating station or attendant.
6. **Calls** may not be transferred to a station that has Do Not Disturb enabled.

**DEFAULT:** 1. Three rings before Transfer Recall.  
2. Automatic Hold is enabled.

---

# FEATURES

## TRANSFER (ONE TOUCH)

The system may be programmed to allow one touch transfer of calls,

### OPERATION

#### **Professional keyset:**

To transfer a call if One Touch Transfer is enabled,

Press: **DSS** key (or SHIFT + DSS key)

### PROGRAMMING

To enable One Touch Transfer,

see System Programming ▸ Call Handling/ One Touch Transfer (5.3.14)

## TRANSFER (SUPERVISED)

The system may be programmed to provide ringing upon transfer when a supervised transfer is made or it may be programmed to allow a direct transfer without ringing.

### OPERATION

When on a call, initiate a Transfer (see *TRANSFER*). Wait for the new station to answer and announce the transfer (Supervised Transfer). When you hang up, the **held call** is automatically connected to the new station without ringing (if RING ON XFR is set to No).

Or, if RING ON XFR is set to YES,

the new station will ring. The user may pick up to access the transferred call.

### PROGRAMMING

See System Programming ▸ Call Handling/ Supervised Transfer Type (5.3.15).

**NOTE:** RING ON XFR will not work with single line telephones (analog keysets).

**FAULT:** RING ON XFR is set to NO.

## TRANSFER ON PAGE

The user may transfer a line call to anyone who answers a page. This allows for the transfer of calls to people who may be away from their **keysets**.

### OPERATION

Place the line call on hold.

Page the party to whom you wish to transfer the call. Remain off-hook until the party answers.

The party you want must answer the page using PAGING ANSWER (F59). Announce the transfer.

Hang up or press the HANDSFREE key.

The **call** will be transferred to the station that responded to the page.

---

## FEATURES

---

### **TRANSFER ON PAGE, cont'd**

- NOTES: 1. The user must place the call on hold, page the party, and hang up without making any other keystrokes in between.
2. See **PAGING** and **PAGING ANSWER** for more detailed instructions.

---

### **USER NAMES PROGRAMMING**

Each station may be assigned a name for easy identification. In most operations, such as making an intercom call to a Professional keyset, the user name will show in the display instead of the station number. For example, instead of 'SET 16 CALLING' the display would say 'TOM CALLING'.

#### PROGRAMMING

See System Programming • Resource/ User Names (5.4.5).

NOTE: The maximum name length is seven characters.

DEFAULT: The user name is **empty** for all stations.

---

### **VOICE CALL**

Each set may be programmed to ring on all Intercom calls or to receive Intercom calls as Voice Calls. If a call is a Voice Call, the receiving station will hear one short ring and the caller may be heard over the speaker.

#### PROGRAMMING

To select whether Intercom **calls** to a set will ring or be Voice Calls, see System Programming • Set/ Intercom (ICM) Type (5.1.12)

- NOTES: 1. Voice Calls may be disabled at a station. See the next feature, **VOICE CALL ENABLE**.
2. Even if ICM Type is set to RING for a particular station, another user may elect to make a V Page to that station. See **PAGING**.

DEFAULT: ICM Type: RING.

---

### **VOICE CALL ENABLE**

A station may enable or disable voice calls and voice paging receipt by turning Voice Call on or off.

#### PROGRAMMING

Press: F • 9 • 8 for Voice Call ON  
Or,  
Press: F • \* • 9 • 8 for Voice call OFF

---

# FEATURES

## VOICE CALL ENABLE, cont'd

NOTE: If Voice Call is Off, an incoming Voice Page Or Voice Call will ring at the called station instead of allowing a Voice Page.

- DEFAULT: 1. All stations will accept Voice paging.  
2. ICM Type: RING

## VOICE MAIL. (AUTOMATED ATTENDANT)

The KSU provides various features that allow complete integration of Voice Mail and automatic attendant servers. This document will use the term "Voice Mail" to describe both types of systems since they are often combined. A Voice Mail system may be connected to one or more station ports of the KSU through a DKS 50 Analog Adapter. The stations that are members of the Hunt Group designated as the 'Voice Mail Hunt Group' will act as Voice Mail ports.

When calls are made to a Voice Mail port, the system can be programmed to prefix the call with an appropriate DTMF header, showing the reason for the call and from which station the call is originating. This allows the voice mail system to respond appropriately with the correct menu or action. Different headers are sent for forwarded calls (six types), Intercom calls, transferred calls, and initial calls. If a system attendant transfers a call, the system will prompt the attendant for a station number so the calling party can access a specific mailbox or menu.

If the Voice Mail system is so equipped, it can perform any of the operations that a single line telephone can perform, such as message notification and call forwarding. See Appendix B.3 • Summary of Single Line Telephone Feature Operation and Programming for applicable feature codes.

In addition, when a station makes a call to a Voice Mail port, the user may press digits on the keypad to interact with the Voice Mail system.

The KSU can also send the Voice Mail DTMF digits when the calling party has hung up. This allows the Voice Mail unit to disconnect more quickly from the call without waiting for a silent period. For external (C.O. Line) calls, the KSU can detect the disconnect pulse that is present on most telephone lines.

## OPERATION

When transferring a call to Voice Mail:

After entering the Voice Mail station number or Hunt Group number, you must enter a two-digit station number. The system will send the mailbox of the entered station to the Voice Mail. The Professional set will prompt for this station on the LCD ("MAILBOX OF" \_\_\_\_).

On an Associate set, since there is no display, just enter the two-digit station number after dialing the transfer.

Example: Voice Mail Hunt Group is #82. An Associate set user wishes to transfer a call to Voice Mail, to Ms. Smith's voice mailbox. Ms. Smith's station number is 14.

Associate set:

Press: HOLD soft key (to put line on hold)

Dial: 82 (Voice Mail Hunt Group number)

Dial: 14 ("Mailbox of:")

Hang up. Call is transferred to Voice Mail. The mailbox number programmed for station 14 is sent as a DTMF signal to Voice Mail.

---

# FEATURES

## VOICE MAIL (AUTOMATED ATTENDANT), *cont'd*

### PROGRAMMING

- To assign ports to a Hunt **Group**,  
see System Programming - **Resource/** Hunt Group Programming (54.18)
- To designate the Hunt Group as a Voice Mail Hunt Group,  
see System Programming - **Resource/** VM Hunt Group Assignment (54.17)
- To program the duration and interdigit intervals of the DTMF headers sent to Voice Mail ports,  
see System Programming - **Call Handling/** VM Header Timing (5.3.7)
- To change the DTMF headers showing the reason for the call and the disconnected header,  
see System Programming - **Peripheral/** Voice Mail (5.6.5)
- To **select** whether the Reason and Originator headers for forwarded calls, transferred calls, Intercom calls, or disconnected calls are sent to Voice Mail,  
see System Programming - **Peripheral/** Voice Mail (5.6.5)
- To select whether the Reason and Originator headers for Initial calls are sent to Voice Mail for each **line**,  
see System Programming - **Line/** Delayed Ring (5.2.8)
- To change the DTMF header (mailbox number) for Initial call originator for each line,  
see System Programming - **Line/** Delayed Ring (5.2.8)
- To set the Voice Mail Hunt Group to answer incoming **calls** on specific C.O. Lines,  
see System Programming - **Line/** Hunt Group Answer (5.2.7)
- To set the minimum **length of** the disconnect pulse on the C.O. Line that the KSU will recognize and **to** enable Loop Break detection,  
see System Programming - **Peripheral/** Loop Break Detection (5.6.7)
- Each station has a private mail box number which can be recognized by the Voice Mail server. To change **this** number,  
see System Programming - **Set/** Mail Box (5.1.8)

- NOTES: 1. A Voice Mail (automated attendant) system may only be connected behind the analog **adapt**
2. If a call is transferred directly to Voice Mail (not forwarded to Voice Mail), the system will **pr** for a station number. The person transferring the call must then enter a station number (or press a DSS key). If 'Originator' is set to 'Y' in System Programming, the system will then **clude** the mailbox number of the station selected in the VM header. This **allows an attenda** transfer to a specific mailbox number.

- DEFAULT:
- 1. No Hunt Group is designated as a Voice Mail Hunt Group.
  - 2. The duration and interdigit interval for voice mail headers are set to 120 milliseconds.
  - 3. Reason (the call is forwarded) header is not sent to the Voice Mail port.
  - 4. Originator header (for forwarded calls) is not sent to the Voice Mail port.

---

# FEATURES

---

## VOICE MAIL (AUTOMATED ATTENDANT), continued

- The Reason and Originator headers for Delayed Ring on each line are not sent to a Voice Mail port.
- "Reason" headers contain the following digits:

Busy Ext.:	<b>9*1</b>
Direct Ext.:	9
No Ans Ext.:	<b>9*2</b>
Busy Int.:	<b>9*1</b>
Direct Int.:	9
No Ans Int.:	<b>9*2</b>
ICM (Intercom) Call:	<b>*</b>
XFR (transfer) call:	Empty
Disconnect:	D
Initial:	<b>Empty</b>

"Ext." stands for an external call (from a C.O. line), "Int." stands for an internal, or Intercom, call.

The first six Reason headers relate to calls forwarded to Voice Mail.

The ICM (Intercom) call header is sent if a station dials Voice Mail directly (rather than being forwarded or transferred).

The XFR header is sent if a call is transferred to Voice Mail.

The Disconnect header is sent when:

- An Intercom call to Voice Mail is ended by the calling party.
  - If Loop Break Detection is enabled and a line call to Voice Mail is terminated by the calling party, the C.O. sends a detectable loop break pulse.
- No Lines are programmed to be answered by a Hunt Group.
  - Loop Break Detection is enabled. The minimum length of the pulse it will detect is 350 milliseconds.
  - The mailbox number assigned to each station is 0 followed by the station number.
  - The Line Identifier (mailbox number) for Initial Calls is 'Empty'.

---

## VOICE MAIL ACCESS

Calls may be directed to the Voice Mail port by a variety of methods. The user may make an Intercom call to any station number that is a member of the Voice Mail Hunt Group, or dial the Voice Mail Hunt Group number (82-89).

Another method is to use the code F - 9 - \* (Voice Mail access). This code will automatically initiate a call to the Voice Mail Hunt Group.

---

# FEATURES

---

## VOICE MAIL ACCESS, cont'd

The code may be programmed **onto** a Programmable feature key. In that case, pressing the key will initiate a call to Voice Mail. If a Voice Mail **Unit leaves** a message at a station with a Voice Mail key, the **LED** next to the key will flash to alert the user that there is a Voice Mail message(s) waiting.

### OPERATION

To call Voice Mail, or reply to a Voice Mail message,

Press: F ■ 9 ■ \*

- NOTES:
1. The LED next to a Voice Mail Feature key will flash only if a message is sent from a Voice Mail unit. It will not light for messages from other stations.
  2. The LED next to a Voice Mail key can only be shut off when the Voice Mail unit sends a "Message Cancel" code (# ■ \* ■ 9 ■ 6 ■ SN). It is not automatically shut off when the station replies to the Voice Mail unit.

---

## VOLUME CONTROL

Each station can separately adjust the level of the following signals:

1. Speaker
2. Handset earpiece
3. Ringing
4. Background Music

### OPERATION

Press the right side of the control to raise the volume, and the left side to lower it. Each press raises or lowers it one step.

If the set is ringing, pressing the volume control will adjust the ring level without affecting the other levels. Similarly, if you are on the handset, speakerphone, or listening to background music, the setting for that function may be adjusted, and will be remembered.

- NOTES:
1. The volume control **also** adjusts LCD contrast • see LCD Contrast.
  2. There are 8 volume levels in adjusting the Handset, Speakerphone, background music, and contrast (0 to 7).
  3. There are 4 ringing volume levels (0 to 3).

DEFAULT:	Speaker	5
	Handset	5
	Ringing	2
	Background Music	5
	LCD contrast	5



---

# SYSTEM PROGRAMMING

## TABLE OF CONTENTS

<b>1. INTRODUCTION</b>	<b>4</b>
<b>2. GENERAL PROGRAMMING PROCEDURES</b>	<b>4</b>
2.1 SELECTING OPTIONS	4
2.2 PASSWORD	4
2.3 ACCESSING SYSTEM PROGRAMMING	4
2.4 PROGRAMMING PROCEDURES	4
2.5 SET COPY AND LINE COPY	5
<b>3. SOFT KEY FUNCTIONS</b>	<b>6</b>
<b>4. DATABASE PROGRAMMING TREE</b>	<b>7</b>
4.1 SET	7
4.2 LINE	8
4.3 CALL HANDLING	8
4.4 RESOURCE	9
4.5 RESTRICTION	12
4.6 PERIPHERAL	14
<b>5. DATABASE PROGRAMMING</b>	<b>16</b>
5.1 SET CATEGORY	17
5.1.1 DAY CLASS OF SERVICE (COS)	17
5.1.2 NIGHT CLASS OF SERVICE (COS)	17
5.1.3 LINE ASSIGNMENT	18
5.1.4 RING ASSIGNMENT	19
5.1.5 SET GROUP ASSIGNMENT	20
5.1.6 SET ZONE NUMBER	21
5.1.7 SET POSITION	21
5.1.8 MAILBOX	22
5.1.9 CALL FORWARD	23
5.1.10 DSS/BLF OWNER	25
5.1.11 LEAST COST ROUTING (LCR) ENABLE	25
5.1.12 INTERCOM (ICM) TYPE	26

---

# SYSTEM PROGRAMMING

---

## TABLE OF CONTENTS

5.2 LINE CATEGORY .....	27
52.1 DAY CLASS, NIGHT CLASS (COS) .....	27
5.22 DIALING TYPE SELECTION .....	28
<b>5.2.3 LINE TYPE</b> .....	28
5.2.4 <b>LINE POOL</b> .....	29
<b>5.2.5 PRIVATE LINE</b> .....	29
5.2.6 PRIVACY .....	30
5.2.7 HUNT GROUP ANSWER .....	31
5.2.8 DELAYED RING .....	31
5.3 CALL HANDLING CATEGORY .....	34
5.3.1 FLASH TIME .....	34
5.3.2 RECALL RINGS .....	34
5.3.3 PAUSE TIME .....	35
5.3.4 PBX CODE .....	35
<b>5.3.5 TONE DURATION</b> .....	36
5.3.6 LONG TONES .....	37
5.3.7 VOICE MAIL HEADER TIMING .....	38
5.3.8 BOSS/SECRETARY PROGRAMMING .....	38
5.3.9 DIRECT INWARD SYSTEM ACCESS (DISA) .....	40
5.3.10 DISA ACCESS CODE .....	41
5.3.11 EXTERNAL CALL FORWARD (ECF) .....	42
5.3.12 AUTOMATIC BUSY REDIAL (ABR) .....	44
5.3.13 DSS/SPD FUNCTION KEY PRIORITY .....	44
5.3.14 ONE TOUCH TRANSFER (XFR) .....	45
5.3.15 SUPERVISED TRANSFER TYPE .....	45
5.3.16 RING ON TALK .....	46
5.4 RESOURCE CATEGORY .....	45
5.4.1 SYSTEM ALARM .....	47
5.4.2 ATTENDANT .....	48

# SYSTEM PROGRAMMING

## TABLE OF CONTENTS

5.4.3 SYSTEM SERVICE MODE .....	50
5.4.4 NIGHT SERVICE (NIGHTSTART/NIGHT END) .....	50
5.4.5 USER NAMES .....	52
5.4.6 SYSTEM SPEED DIALING (SPD) .....	53
5.4.7 SYSTEM PASSWORD (DB PSWD) .....	55
5.4.8 CALL MONITOR PASSWORD .....	55
5.4.9 SYSTEM TIME .....	57
5.4.10 SET COPY .....	58
5.4.11 LINE COPY .....	60
5.4.12 USER PASSWORD .....	61
5.4.13 MESSAGES .....	62
5.4.14 HOUR MODE SELECTION .....	64
5.4.15 KSU REVISION .....	65
5.4.16 DEFAULT SETTING (SYSTEM) .....	66
5.4.17 VOICE MAIL (VM) HUNT GROUP ASSIGNMENT .....	67
5.4.18 HUNT GROUP PROGRAMMING .....	67
5.5 RESTRICTION CATEGORY .....	69
5.5.1 TOLL RESTRICTION .....	69
5.5.2 LEAST COST ROUTING (LCR) .....	77
5.6 PERIPHERAL CATEGORY .....	86
5.6.1 STATION MESSAGE DETAIL RECORDING (SMDR) OUTPUT .....	86
5.6.2 RS232C (RMT) DATA RATE (X-RATE) .....	87
5.6.3 LOUD BELL INTERFACE .....	87
5.6.4 SINGLE LINE TELEPHONE (SLT) HOOK FLASH TIME .....	90
5.6.5 VOICE MAIL .....	91
5.6.6 MODEM SETUP .....	94
5.6.7 LOOP BREAK DETECTION .....	95

---

# SYSTEM PROGRAMMING

## 1. INTRODUCTION

System Programming is used to choose from the many system options available for the Landmark Digital Key System. There are Options that may be programmed by the user at his or her own set, and there are system options that can only be changed by an attendant who knows the system password (See "Feature Access Codes" in the Features section of this manual for a list of options selectable by the users).

## 2. GENERAL PROGRAMMING PROCEDURES

### 2.1 SELECTING OPTIONS

Using the worksheet provided in the Programming Records section, write down all the system options chosen for this particular key system.

Then, access the system programming and make the necessary changes.

The worksheet notes the default options. These are the options present after a cold reset of the system. If you want to use those options, you do not need to program them. You only need to program the options you want to change.

### 2.2 PASSWORD

It is necessary to enter the system password to program the system. The system password is 6 digits long and defaults to "000000" on a cold reset of the system. It may be changed, as shown below.

### 2.3 ACCESSING SYSTEM PROGRAMMING

At a

Professional keyset:

Press: Feature - # - \* .

The display will prompt you for the password.

Enter: 000000 (or present password).

Press: SHOW soft key.

The display will now show the first item in the programming menu.

NOTE: If you wish to change the system password, please refer to section 5.4.7, System Password.

### 2.4 PROGRAMMING PROCEDURES

The soft keys on the display are used to move through the programming menu. For example, pressing the NEXT soft key shows the next item on the menu. It is easy to reprogram any item by following these steps

1. Move through the menu by pressing the NEXT soft key until the display shows the category you wish to reprogram. The categories are:

1. SET
2. LINE
3. CALL HANDLING
4. RESOURCE
5. RESTRICTION
6. PERIPHERAL

---

# SYSTEM PROGRAMMING

## 2. GENERAL PROGRAMMING PROCEDURES, cont'd

2. Press the SHOW soft key. Depending on which Category you selected, the display will prompt you for a set or line number, or show you the first option. If prompted, enter the set or line number, then the SHOW soft key.
3. Press the NEXT soft key to move the option in the category you wish to program.
4. Press the CHG (change soft key) to change the option. You will see that some options require you to enter a number, then press the SAVE soft key, and others will show you a different option each time you press the CHG soft key.
5. Press the NEXT or BACK soft key to move to a different programming option.
6. At any time you may move up one level in programming by pressing the SHIFT hard key. For example, in the RESOURCE category, the USER NAMES option is followed by the SYSTEM SPEED DIAL option. When you are finished programming User Names, you may press the NEXT soft key to move on to System Speed Dial, or you may press the SHIFT hard key to move the menu back up to the RESOURCE category title.
7. Press RLS (release) to exit system programming at any time, or use the SAVE soft key if available for that particular category. All your changes will be saved.

### 2.5 SET COPY AND LINE COPY

Two particularly useful programming options in the RESOURCE category are Set Copy and Line Copy. Using these tools allows you to program one set or line, then Copy its programming over to other sets or lines that you want to have the same (or similar) options. This avoids having to re-enter the settings for every set and line.

, summary of all the soft keys and their functions follows.

---

# SYSTEM PROGRAMMING

## 3. SOFT KEY FUNCTIONS

### 1. BKSP (Backspace)

When the new programming data entry is not desired, station user may press BKSP soft key to erase the last entered digit and be ready to enter new data again.

### 2. SAVE (Store)

When the new programming data is entered, the system will check the entered-data automatically.

If the data entry is invalid, the programming prompt will be refreshed.

If the data entry is valid, the station user must press the **SAVE** soft key to confirm the validity and then the programming will go to the next item or even the next category.

### 3. CHG (Change)

a. Press the **CHG** soft key to modify the content of the current programming item.

b. If the data/message to be changed is generated by the system itself, the content of the current programming item would be replaced by the new data (toggled between Yes and No, or cycled through several data/messages) when the station user presses the CHG soft key.

c. If the new programming data is not generated by the system, the station user may press the CHG soft key in order to refresh the programming prompt and enter new data.

### 4. NEXT

Press the **NEXT** soft key to proceed to the next programming item within the same category or to go to the next category if the current feature item is the last one in that particular category.

### 5. BACK

Press the **BACK** soft key to return to the previous programming item within the same category or to the previous category if the current feature item is the first one in that particular category.

### 6. SHOW (Display)

Press the **SHOW** soft key to enter detailed feature item programming into a specific category or to display the current programmed content of such a featured item.

### 7. EXIT

The **EXIT** function will be executed by pressing the **SHIFT** hard key. This will abandon not only the feature programming item, but also its feature category and return to the next highest category level.

---

# SYSTEM PROGRAMMING

---

## 4. DATABASE PROGRAMMING TREE

### 4.1 SET

SHOW SET:      (10 - 81, i.e., existing set number)

DAY CLASS: X (0 - 7)

NIGHT CLASS: X (0 - 7)

LINE ASSIGNMENT

LINE 1: X (Y/N)

LINE 2: X

LINE 6: x

RING ASSIGNMENT

DAY RING

LINE 1: X (Y/N)

LINE 2: X

LINE 6: x

NIGHT RING

LINE 1: X (Y/N)

LINE 2: X

LINE 6: x

SET GROUP: X (1 - 8)

ZONE NUMBER: X (1 - 2)

SET POSITION: XX (10 - 81, i.e., existing set number)

SET POSITION:     

MAIL BOX: XXX (001 - 999)

MAIL BOX:     

CALL FORWARD

BUSY TO: XX (10 - 81, i.e., existing set number/ 82-88, Hunt Groups 1-8/ NONE)

NO\_ANS TO: XX (10 - 81, i.e., existing set number/ 82-88, Hunt Groups 1-8/ NONE)

DELAY TIME: XX (1 0/20/26/32 seconds)

DSS/BLF FOR: XX (10 - 81, i.e., existing set number/NONE)

LCR ENABLE: X (Y/N)

ICM TYPE: XXXXX (RING/VOICE)

---

# SYSTEM PROGRAMMING

## 4. DATABASE PROGRAMMING TREE, cont'd

### 4.2 LINE

SHOW LINE: <input type="checkbox"/>	2 digits (01 - 06)
DAY CLASS: X	(0 - 7)
NIGHT CLASS: X	(0 - 7)
DIALING: XXXXX	(TONE/PULSE)
LINE TYPE: XXX	(CO/PBX)
LINE POOL: X	(1 - 8)
PRIVATE TO: XX	(10 - 81, i.e., existing set number/NONE)
PRIVATE TO: <input type="checkbox"/>	(10 - 81, i.e., <b>existing</b> set number/NONE)
PRIVACY: X	(Y/N)
HUNT GROUP ANS	
DAY MODE: X	(N, 1 - 8)
NIGHT MODE: X	(N, 1 - 8)
DELAYED RING	
DELAY TIME: XX	(N, 10, 20, 26, 32 sec)
MAILBOX: XXX	(000-999, except existing station's mailbox)
REASON: X	(Y/N)
ORIGINATOR: X	(Y/N)
DESTINATION	
FIRST: XX	(10-81, i.e., existing set number/ Hunt Group <b>82-88/ NO</b> )
SECOND: XX	(10-81, i.e., existing set number/ Hunt Group <b>82-88/ NO</b> )

### 4.3 CALL HANDLING

FLASH TIME: XXX	(0.1 - 1.5 seconds)
RECALL RINGS: X	(1 - 8 rings)
PAUSE TIME: XXX	(1.5/2/3.5/5 seconds)
PBX CODE: XX	(0 - 9 or 00 - 99, maximum 2 digits)
PBX CODE: <input type="checkbox"/>	
TONE TIME: XXX	(70/1 20/1 50 ms)
LONG TONES: XXXX	(200/300/.../1500 ms)
VM HEADER TIMING	
TONE ON: XXX	(90/1 20/1 50 ms)
TONE OFF: XXX	(90/1 20/1 50 ms)

---

# SYSTEM PROGRAMMING

---

## 4. DATABASE PROGRAMMING TREE, cont'd

### BOSS/SECRETARY

SECRETARY: \_ (IO - 81, i.e., existing set number)  
BOSS 1: XX (IO - 81, i.e., existing set number/NONE)  
BOSS 1: \_  
BOSS 2: XX (IO - 81, i.e., existing set number/NONE)  
BOSS 2: \_

### DISA

ACTIVE LINE: \_ (01 - 06)  
DISA LINE: X (Y/N)  
SERVICE: XXXXXX (DAY/NIGHT/ALWAYS)  
DISA RINGS: X (1 - 5)

### DISA

ACCESSCODE  
01. xxxxxxxxxx (9 Digits/EMPTY)  
01. \_  
  
02. xxxxxxxxxx  
  
24. XXXXXXXXXX

### EXTERNAL CFW

ACTIVE LINE: \_ (01 - 06)  
TYPE: XXXXXXXX (NONE/INCOMING/OUTGOING)  
SERVICE: XXXXXX (DAY/NIGHT/ALWAYS)

### AUTOMATIC BUSY REDIAL

ABR REPEAT: XX (0, 1 - 15 times)  
ABR INTERVAL: XXX (1 0/30/60/90/1 20 seconds)

KEY PRIORITY: XXX (SPD/DSS)

ONE TOUCH XFR: X (Y/N)

SUPERVISED TRANSFER:  
RING ON XFR: X (Y/N)

RING ON TALK: X (Y/N)

## 4 RESOURCE

### SYSTEM ALARM

ALARM 1: XX:XX 24 hour system  
ALARM 1: \_ (00:00 - 23:59/ NONE)  
ALARM 2: XX:XX

---

# SYSTEM PROGRAMMING

## 4. DATABASE PROGRAMMING TREE, cont'd

ALARM 8: XX:XX  
ALARM 8: \_

ATTENDANT  
ZONE 1: XX (10 • 81, i.e., existing set number/NONE)  
ZONE 1: \_  
ZONE 2: XX (10 • 81, i.e., existing set number/NONE)  
ZONE 2: \_

SERVICE: XXXXX (DAY/NIGHT/TIME)

NIGHT START: XX:XX 24 hour system  
NIGHT START: \_ (00:00 • 23:59/ NONE)

NIGHT END: XX:XX 24 hour system  
NIGHT END: \_ (00:00 • 23:59/ NONE)

USER NAMES  
SHOW SET: XX (10 • 81, i.e., existing set number)  
SET XX: XXXXXXXX (Maximum 7 characters/EMPTY)

SYSTEM SPD  
SHOW SPD: XX (25 • 99)  
XXXXXXXXXXXXXXXXXXXX (Maximum 16 digits/EMPTY)

PASSWORD: XXXXXX (6 digits)  
PASSWORD: \_

MONITOR PASSWORD  
GROUP 1: XXXX (4 digits)  
GROUP 1:  
  
GROUP 8: XXXX (4 digits)  
GROUP 8:

SYSTEM TIME  
YEAR: XXXX (0000 • 9999)  
YEAR: \_  
MONTH: XXX (JAN/FEB/.../NOV/DEC)  
DAY: XX (01 • 31)  
DAY: \_  
WEEKDAY: XXX (MON/.../SAT/SUN)  
HOUR: XX (00 • 23)  
HOUR: \_  
MINUTE: XX (00 • 59)  
MINUTE:

SET COPY  
COPY FROM: \_ (10 • 81, i.e., existing set number)  
COPY TO: \_ (10 • 81, i.e., existing set number)

---

# SYSTEM PROGRAMMING

## 4. DATABASE PROGRAMMING TREE, cont'd

LINE COPY  
COPY FROM: \_ (01 - 06)  
COPY TO: \_ (01 - 06)

USER PASSWORD  
SHOW SET: \_ (10 - 81, i.e., existing set number)  
SET PSWD: XXXX (4 digits), **PSWD** = PASSWORD

MESSAGES  
SPECIAL MESSAGE  
XXXXXXXXXXXXXXXXXX (Maximum 16 characters/EMPTY)  
XXXXXXXXXXXXXXXXXX  
XXXXXXXXXXXXXXXXXX

ADVISORY MESSAGE  
XXXXXXXXXXXXXXXXXX (Maximum 16 characters/EMPTY)  
XXXXXXXXXXXXXXXXXX  
XXXXXXXXXXXXXXXXXX

HR  
HOUR MODE: XX (12/24)

KSU REVISION  
KSU: XXXXXXXXXXX (Maximum 10 characters)

DEFAULT SETTING  
PASSWORD: XXXXXX (6 digits)  
ARE YOU SURE? (Y/N)

VM HUNT GROUP: X (N, 1 - 8)

HUNT GROUP  
HUNT GROUP: (N, 1 - 8)  
HUNT FROM: XXXXX (FIRST/NEXT)  
GROUP MEMBER  
MEMBER 01: XX (10 - 81, i.e., existing set number/NONE)  
MEMBER 01: \_  
  
MEMBER 24: XX (10 - 81, i.e., existing set number/NONE)  
MEMBER 24: \_

---

# SYSTEM PROGRAMMING

## 4. DATABASE PROGRAMMING TREE, cont'd

### 4.5 RESTRICTION

TOLL RESTRICTION

RESTRICT TABLE

TABLE ENTRY:          (01 - 50)

RESTRICT NUMBER  
XXXXXXX (8 digits)

STATION COS

DAY COS

cos 0: x (Y/N)

cos 7: x

NIGHT COS

cos 0: x (Y/N)

cos 7: x

LINE COS

DAY COS

cos 0: x (Y/N)

COS 7: x

NIGHT COS

cos 0: x (Y/N)

cos 7: x

EXCEPTION TABLE

TABLE ENTRY:          (01 - 20)

EXCEPTION NUMBER  
XXXXXXXXXXXXXXXXX (14 digits)

STATION COS

DAY COS

cos 0: x (Y/N)

COS 7: x

---

# SYSTEM PROGRAMMING

## 4. DATABASE PROGRAMMING TREE, cont'd

NIGHT COS  
cos 0: x (Y/N)

cos 7: x

LINE COS  
DAY COS  
cos 0: x (Y/N)

COS 7: x

NIGHT COS  
cos 0: x (Y/N)

cos 7: x

LCR

DIGIT COMPARISON  
TABLE ENTRY: \_ (001 - 100)  
FROM  
XXXXXXXXXXXXXXXX (14 digits, 0-9, \*/EMPTY)

TO  
XXXXXXXXXXXXXXXX (14 digits, 0-9, \*/EMPTY)

TIME OF DAY LIST  
MONDAY: XX (NONE/01-10)  
TUESDAY: XX (NONE/01-10)

SUNDAY: XX (NONE/01-10)

TIME OF DAY LIST  
TABLE NUMBER: \_ (01 - 10)  
TABLE ENTRY: \_ (1 - 6)  
TIME: XX:XX (NONE/00:00 - 2359)  
TIME: \_  
POOL LIST: X (NONE/I - 8)

---

# SYSTEM PROGRAMMING

## 4. DATABASE PROGRAMMING TREE, conf'd

POOL LIST  
TABLE ENTRY:    (1 - 8)  
CHOICE  
CHOICE 1: X (1 - 8/NONE)  
CHOICE 2: X (1 - 8/NONE)  
CHOICE 3: X (1 - 8/NONE)  
CHOICE 4: X (1 - 8/NONE)  
DMT NO. (DMT - DIGIT MODIFICATION TABLE)  
DMTNO. 1: X (1 - 8/NONE)  
DMT NO. 2: X (1 - 8/NONE)  
DMT NO. 3: X (1 - 8/NONE)  
DMT NO. 4: X (1 - 8/NONE)

DGT MODIFICATION  
TABLE ENTRY:    (1 - 8)  
DELETE DGT: XX (1 - 12/NONE)  
INSERT DIGIT  
XXXXXXXXXXXXXXXXXX (16 digits, O-S/Pause/EMPTY)

### 4.6 PERIPHERAL

SMDR OUTPUT  
INCOMING CALL: X (Y/N)  
ACCOUNT CODE: X (Y/N)

RMT X\_RATE:XXXXX (11 0/300/600/1 200/2400/4800/9600/19200 bps)

SMDR X\_RATE:XXXXX (11 0/300/600/1 200/2400/4800/9600/19200 bps)

LOUD BELL  
SERVICE: XXXXXXX (DISABLE/DAY/NIGHT/ALWAYS)

POOL  
POOL 1: X (Y/N)  
POOL 2: x (Y/N)

POOL 8: X (Y/N)

LINE  
LINE 01: X (Y/N)

LINE 06: X (Y/N)

STATION: XX (10 - 81, i.e., existing set number/NONE)

# SYSTEM PROGRAMMING

## 4. DATABASE PROGRAMMING TREE, cont'd

### SLT HOOK FLASH

MINIMUM TIME: XXXX (60/1 00/200/.../1300/1 400 msec)  
MAXIMUM TIME: XXXX (100/200/.../1400/1500 msec)

### VOICE MAIL

#### REASONS FOR CALL FORWARD

BUSY EXT: XXXXX (EMPTY/Maximum 5 digits), EXT = EXTERNAL  
BUSY EXT: \_  
DIRECT EXT: XXXXX (EMPTY/Maximum 5 digits)  
DIRECT EXT: \_  
O\_ANS EXT: XXXXX (EMPTY/Maximum 5 digits)  
NO-ANS EXT: \_  
BUSY INT: XXXXX (EMPTY/Maximum 5 digits), INT = INTERNAL  
BUSY INT: \_  
DIRECT INT: XXXXX (EMPTY/Maximum 5 digits)  
DIRECT INT: \_  
NO-ANS INT: XXXXX (EMPTY/Maximum 5 digits)  
NO-ANS INT: \_  
ICM CALL: XXXXX (EMPTY/Maximum 5 digits), ICM = INTERCOM  
ICM CALL: \_  
XFR CALL: XXXXX (EMPTY/Maximum 5 digits), XFR = TRANSFER  
XFR CALL: \_  
DISCONNECT: XXXXX (EMPTY/Maximum 5 digits)  
DISCONNECT: \_  
INITIAL: XXXXX (EMPTY/Maximum 5 digits)  
INITIAL: \_

#### VOICE MAIL (VM) ACCESS CONDITIONS

REASON: X (Y/N)  
ORIGINATOR: X (Y/N)

### MODEM SETUP

XXXXXXXXXXXXXXXXXXXX (DEFAULT: &FE0&Q0S0=3/Maximum 16 digits)

### LOOP BREAK

SERVICE: XXXXXXXX (DISABLE/ENABLE)  
BREAK TIME: XXX (300/350/400/.../900 msec)

# SYSTEM PROGRAMMING

## 5. DATABASE PROGRAMMING

### ACTION

### RESULT

Data Base Access Code Entry:  
Press: F # . . . 000000

PASSWORD	000000	
BKSP	SHOW	CHG
<input type="text"/>	<input type="text"/>	<input type="text"/>

Press: SHOW

1. SET		
SBACK	HNEXT	W
<input type="text"/>	<input type="text"/>	<input type="text"/>

Press: NEXT

2. LINE		
BACK	NEXT	SHOW
<input type="text"/>	<input type="text"/>	<input type="text"/>

Press: NEXT

3. CALL HANDLING		
BACK	NEXT	SHOW
<input type="text"/>	<input type="text"/>	<input type="text"/>

Press: NEXT

4. RESOURCE		
BACK	NEXT	SHOW
<input type="text"/>	<input type="text"/>	<input type="text"/>

Press: NEXT

5. RESTRICTION		
BACK	NEXT	SHOW
<input type="text"/>	<input type="text"/>	<input type="text"/>

Press: NEXT

6. PERIPHERAL		
BACK	NEXT	SHOW
<input type="text"/>	<input type="text"/>	<input type="text"/>

# SYSTEM PROGRAMMING

## 5.7 SET CATEGORY

### ACTION

### RESULT

Press: **NEXT**

1. SET		
BACK	NEXT	SHOW
<input type="text"/>	<input type="text"/>	<input type="text"/>

Press: **SHOW**

SHOW SET:		
BKSP	SHOW	CHG
<input type="text"/>	<input type="text"/>	<input type="text"/>

Press: 11

1 0 8 1	<input type="text"/>	existing set numbers
SHOW SET: 11		
BKSP	SHOW	CHG
<input type="text"/>	<input type="text"/>	<input type="text"/>

## 5.1.1 DAY CLASS OF SERVICE (COS)

### ACTION

### RESULT

Press: **SHOW**

DAY CLASS: 0		
BACK	NEXT	CHG
<input type="text"/>	<input type="text"/>	<input type="text"/>

0/1.../7

Press: **CHG**

DAY CLASS: 1		
BACK	NEXT	CHG
<input type="text"/>	<input type="text"/>	<input type="text"/>

## 5.1.2 NIGHT CLASS OF SERVICE (COS)

Press: **NEXT**

NIGHT CLASS: 0		
BACK	NEXT	CHG
<input type="text"/>	<input type="text"/>	<input type="text"/>

0/1.../7

Press: **CHG**

NIGHT CLASS: 1		
BACK	NEXT	CHG
<input type="text"/>	<input type="text"/>	<input type="text"/>

0/1.../7

- NOTES: 1. Either Day or Night COS of the station will be active according to the service mode of the system.  
2. Station's COS is associated with Toll Restriction.

**DEFAULT:** All stations are set for Day and Night COS '0'.

---

# SYSTEM PROGRAMMING --

## 5.1 SET CATEGORY, cont'd

### 5.1.3 LINE ASSIGNMENT

<u>ACTION</u>		<u>RESULT</u>	
Press: NEXT	<div style="border: 1px solid black; padding: 5px; display: inline-block;">LINE ASSIGNMENT BACK    NEXT    SHOW</div> <div style="display: flex; justify-content: space-around; width: 100%;"><div style="border: 1px solid black; width: 30%; height: 10px;"></div><div style="border: 1px solid black; width: 30%; height: 10px;"></div><div style="border: 1px solid black; width: 30%; height: 10px;"></div></div>		
Press: SHOW		<div style="border: 1px solid black; padding: 5px; display: inline-block;">LINE 1: Y BACK    NEXT    CHG</div> <div style="display: flex; justify-content: space-around; width: 100%;"><div style="border: 1px solid black; width: 30%; height: 10px;"></div><div style="border: 1px solid black; width: 30%; height: 10px;"></div><div style="border: 1px solid black; width: 30%; height: 10px;"></div></div>	Y/N
Press: NEXT		<div style="border: 1px solid black; padding: 5px; display: inline-block;">LINE 2: Y BACK    NEXT    CHG</div> <div style="display: flex; justify-content: space-around; width: 100%;"><div style="border: 1px solid black; width: 30%; height: 10px;"></div><div style="border: 1px solid black; width: 30%; height: 10px;"></div><div style="border: 1px solid black; width: 30%; height: 10px;"></div></div>	Y/N
Press: NEXT		<div style="border: 1px solid black; padding: 5px; display: inline-block;">LINE 6: Y BACK    NEXT    CHG</div> <div style="display: flex; justify-content: space-around; width: 100%;"><div style="border: 1px solid black; width: 30%; height: 10px;"></div><div style="border: 1px solid black; width: 30%; height: 10px;"></div><div style="border: 1px solid black; width: 30%; height: 10px;"></div></div>	YIN
Press: CHG		<div style="border: 1px solid black; padding: 5px; display: inline-block;">LINE 6: N <del>BACK</del>    NEXT</div> <div style="display: flex; justify-content: space-around; width: 100%;"><div style="border: 1px solid black; width: 30%; height: 10px;"></div><div style="border: 1px solid black; width: 30%; height: 10px;"></div><div style="border: 1px solid black; width: 30%; height: 10px;"></div></div>	YIN

- NOTES: 1. Any station may use a line key or line pool key in order to access an idle line or to answer an incoming or held line call.
2. The user may freely **assign** any feature key with a dual colored LED as an individual line key as a certain line pool key regardless of whether the line(s) corresponding to the programmed (pool) key is (are) accessible to the station. In addition, **DSS/SPD** keys on the DKS 930 may be programmed as line or pool keys.

DEFAULT: All lines are accessible to all stations.

# SYSTEM PROGRAMMING

## 5.1 SET CATEGORY, cont'd

### 5.1.4 RING ASSIGNMENT

ACTION

RESULT

Press: **NEXT**

RING ASSIGNMENT		
BACK	NEXT	SHOW
<input type="text"/>	<input type="text"/>	<input type="text"/>

Press: **SHOW**

DAY RING		
BACK	NEXT	SHOW
<input type="text"/>	<input type="text"/>	<input type="text"/>

Press: **SHOW**

LINE 01: N		
BACK	NEXT	CHG
<input type="text"/>	<input type="text"/>	<input type="text"/>

Y/N

Press: **NEXT**

LINE 02: N		
BACK	NEXT	CHG
<input type="text"/>	<input type="text"/>	<input type="text"/>

Y/N

Press: **NEXT**

LINE 06: N		
BACK	NEXT	CHG
<input type="text"/>	<input type="text"/>	<input type="text"/>

Y/N

Press: **CHG**

LINE 06: Y		
BACK	NEXT	CHG
<input type="text"/>	<input type="text"/>	<input type="text"/>

Press: **NEXT**

NIGHT RING		
BACK	NEXT	SHOW
<input type="text"/>	<input type="text"/>	<input type="text"/>

Press: **SHOW**

LINE 01: N		
BACK	NEXT	CHG
<input type="text"/>	<input type="text"/>	<input type="text"/>

Y/N

---

# SYSTEM PROGRAMMING --

## 5.1 SET CATEGORY, cont'd

<u>ACTION</u>	<u>RESULT</u>										
Press: <b>NEXT</b>	<table border="1"><tr><td>LINE 02: N</td><td></td><td></td></tr><tr><td>BACK</td><td>NEXT</td><td>CHG</td></tr><tr><td><input type="text"/></td><td><input type="text"/></td><td><input type="text"/></td></tr></table>	LINE 02: N			BACK	NEXT	CHG	<input type="text"/>	<input type="text"/>	<input type="text"/>	Y/N
LINE 02: N											
BACK	NEXT	CHG									
<input type="text"/>	<input type="text"/>	<input type="text"/>									
Press: <b>NEXT</b>	<table border="1"><tr><td>LINE 06: N</td><td></td><td></td></tr><tr><td>BACK</td><td>NEXT</td><td>CHG</td></tr><tr><td><input type="text"/></td><td><input type="text"/></td><td><input type="text"/></td></tr></table>	LINE 06: N			BACK	NEXT	CHG	<input type="text"/>	<input type="text"/>	<input type="text"/>	Y/N
LINE 06: N											
BACK	NEXT	CHG									
<input type="text"/>	<input type="text"/>	<input type="text"/>									
Press: <b>CHG</b>	<table border="1"><tr><td>LINE 06: Y</td><td></td><td></td></tr><tr><td>BACK</td><td>NEXT</td><td>CHG</td></tr><tr><td><input type="text"/></td><td><input type="text"/></td><td><input type="text"/></td></tr></table>	LINE 06: Y			BACK	NEXT	CHG	<input type="text"/>	<input type="text"/>	<input type="text"/>	
LINE 06: Y											
BACK	NEXT	CHG									
<input type="text"/>	<input type="text"/>	<input type="text"/>									

- NOTES:**
1. A station with ring assignment will hear an incoming line call ringing. A station without ring assignment will not ring, but the corresponding line (pool) LED will flash and this station may answer the call.
  2. The 'Ring Assignment' is associated with the system service mode.

**DEFAULT:** All stations except for the attendant of Zone 1 (station 10) do NOT ring when a call is coming on a line.

### 5.1.5 SET GROUP ASSIGNMENT

<u>ACTION</u>	<u>RESULT</u>										
Press: <b>NEXT</b>	<table border="1"><tr><td>SET GROUP: 1</td><td></td><td></td></tr><tr><td>BACK</td><td>NEXT</td><td>CHG</td></tr><tr><td><input type="text"/></td><td><input type="text"/></td><td><input type="text"/></td></tr></table>	SET GROUP: 1			BACK	NEXT	CHG	<input type="text"/>	<input type="text"/>	<input type="text"/>	1/2/.../8
SET GROUP: 1											
BACK	NEXT	CHG									
<input type="text"/>	<input type="text"/>	<input type="text"/>									
Press: <b>CHG</b>	<table border="1"><tr><td>SET GROUP: 2</td><td></td><td></td></tr><tr><td>BACK</td><td>NEXT</td><td>CHG</td></tr><tr><td><input type="text"/></td><td><input type="text"/></td><td><input type="text"/></td></tr></table>	SET GROUP: 2			BACK	NEXT	CHG	<input type="text"/>	<input type="text"/>	<input type="text"/>	1/2/.../8
SET GROUP: 2											
BACK	NEXT	CHG									
<input type="text"/>	<input type="text"/>	<input type="text"/>									

# SYSTEM PROGRAMMING

## 5.1 SET CATEGORY, cont'd

### ACTION

### RESULT

press: CHG

SET GROUP: 8		
BACK	NEXT	CHG
<input type="text"/>	<input type="text"/>	<input type="text"/>

1/2/.../8

**NOTE:** Station Group is associated with Call Monitoring and Group Call Pickup.

**DEFAULT:** All stations belong to station Group 1.

## 5.1.6 SET ZONE NUMBER

### ACTION

### RESULT

Press: NEXT

ZONE NUMBER: 1		
BACK	NEXT	CHG
<input type="text"/>	<input type="text"/>	<input type="text"/>

1/2

Press: CHG

ZONE NUMBER: 2		
BACK	NEXT	CHG
<input type="text"/>	<input type="text"/>	<input type="text"/>

If the station is assigned as the attendant of Zone 1, then the Zone number can not be changed

**NOTE:** Station Zone is associated with 'Call Operator'.

**DEFAULT:** All stations belong to station zone 1.

## 5.1.7 SET POSITION

### ACTION

### RESULT

Press: NEXT

SET POSITION: 11		
BACK	NEXT	CHG
<input type="text"/>	<input type="text"/>	<input type="text"/>

Press: CHG

SET POSITION: _		
BKSP	SAVE	CHG
<input type="text"/>	<input type="text"/>	<input type="text"/>

34 - 57, which are system recognizable set numbers

---

# SYSTEM PROGRAMMING

## 5.1 SET CATEGORY, cont'd

<u>ACTION</u>	<u>RESULT</u>				
Press: 56	<table border="1"><tr><td>SET POSITION: 56</td></tr><tr><td>BKSP      SAVE      CHG</td></tr><tr><td>_____</td></tr></table>	SET POSITION: 56	BKSP      SAVE      CHG	_____	The number '56' has to be system allowable
SET POSITION: 56					
BKSP      SAVE      CHG					
_____					
Press: <b>SAVE</b>	<table border="1"><tr><td>SET POSITION: 56</td></tr><tr><td>BACK      NEXT      CHG</td></tr><tr><td>_____</td></tr></table>	SET POSITION: 56	BACK      NEXT      CHG	_____	Now position 11 is vacant, replaced by the new number 56
SET POSITION: 56					
BACK      NEXT      CHG					
_____					

**NOTE:** The station number may be easily changed to a vacant number not assigned to another station.

- DEFAULT:**
1. Station numbers range from 10 to 33 and are assigned to every station port sequentially in position order.
  2. If an analog adapter is connected, the numbers from 58 to 81 is used as the set numbers when the voice is carried over the **B2** channel.
  3. Station numbers that range from 82 to 89 are used for Hunt Group numbers (82 for Hunt Group 1, 83 for Hunt Group 2, etc.).
  4. Station numbers that range from 34 to 57 are vacant.

### 5.1.8 MAILBOX

<u>ACTION</u>	<u>RESULT</u>				
Press: <b>NEXT</b>	<table border="1"><tr><td>MAIL BOX: 011</td></tr><tr><td>BACK      NEXT      CHG</td></tr><tr><td>_____</td></tr></table>	MAIL BOX: 011	BACK      NEXT      CHG	_____	The mailbox number of Set 11 is '011' (0 + station number).
MAIL BOX: 011					
BACK      NEXT      CHG					
_____					
Press: <b>CHG</b>	<table border="1"><tr><td>MAIL BOX: _</td></tr><tr><td>BKSP      SAVE      CHG</td></tr><tr><td>_____</td></tr></table>	MAIL BOX: _	BKSP      SAVE      CHG	_____	(001 - 999)
MAIL BOX: _					
BKSP      SAVE      CHG					
_____					
Press: 999	<table border="1"><tr><td>MAIL BOX: 999</td></tr><tr><td>BKSP      SAVE      CHG</td></tr><tr><td>_____</td></tr></table>	MAIL BOX: 999	BKSP      SAVE      CHG	_____	The number '999' has to be unoccupied
MAIL BOX: 999					
BKSP      SAVE      CHG					
_____					

---

# SYSTEM PROGRAMMING

## 3.1 SET CATEGORY, cont'd

### ACTION

### RESULT

Press: SAVE

MAIL BOX: 999		
BACK	NEXT	CHG
<input type="text"/>	<input type="text"/>	<input type="text"/>

Now mailbox '011' is not recognizable to the VM system

- NOTES:**
1. The mailbox number assignment is dependent on the attribute of the connected voice mail system.
  2. The valid range for the mailbox number is from '001' to '999' (three digits) only.

**DEFAULT:** The mailbox number (three digits) is the same as 0 + station number.

## 3.1.9 CALL FORWARD

### ACTION

### RESULT

Press: NEXT

CALL FORWARD		
BACK	NEXT	SHOW
<input type="text"/>	<input type="text"/>	<input type="text"/>

Press: SHOW

BUSY TO: 10		
BACK	NEXT	CHG
<input type="text"/>	<input type="text"/>	<input type="text"/>

Press: CHG

BUSY TO: _		
BKSP	SAVE	CHG
<input type="text"/>	<input type="text"/>	<input type="text"/>

10 - 81, an existing set number  
82 - 89, existing hunt group

Press: 23

BUSY TO: 23		
BKSP	SAVE	CHG
<input type="text"/>	<input type="text"/>	<input type="text"/>

Press: SAVE

BUSY TO: 23		
BACK	NEXT	CHG
<input type="text"/>	<input type="text"/>	<input type="text"/>

# SYSTEM PROGRAMMING

## 5.1 SET CATEGORY, cont'd

<u>ACTION</u>	<u>RESULT</u>	
Press: <b>NEXT</b>	NO-ANS TO: NONE BACK      NEXT      CHG _____	
Press: <b>CHG</b>	NO-ANS TO: BKSP      SAVE      CHG _____	
Press: 13	NO-ANS TO: 13 BKSP      SAVE      CHG _____ _____	10-81, existing set number 82-89, existing Hunt Group
Press: <b>SAVE</b>	NO-ANS TO: 13 BACK      NEXT      CHG _____	
Press: <b>NEXT</b>	DELAY TIME: 26 BACK      NEXT      CHG _____	The programming range is 1 0/20/26/32 seconds
Press: <b>CHG</b>	DELAY TIME: 32 BACK      NEXT      CHG _____	The programming range is 1 0/20/26/32 seconds

- NOTES:**
1. The 'CALL FORWARD' programmed at the station has a higher priority than the two call forwarding in the database. type:
  2. Because 'CALL FORWARD' is mutually exclusive with 'DND', if the station has DND call forwarding destination can not be programmed. enat

**DEFAULT:** Call Forwarding is not enabled at any station. The default delay time is 26 seconds.

# SYSTEM PROGRAMMING

## 5.1 SET CATEGORY, cont'd

### 5.1.10 DIRECT STATION SELECT/BUSY LIGHT FIELD (DSS/BLF) OWNER

#### ACTION

#### RESULT

Press: **NEXT**

DSS/BLF FOR: NONE		
BACK	NEXT	CHG
<input type="text"/>	<input type="text"/>	<input type="text"/>

NONE/10-81, i.e., existing station number

Press: **CHG**

DSS/BLF FOR: _		
BKSP	SAVE	CHG
<input type="text"/>	<input type="text"/>	<input type="text"/>

Press: 10

DSS/BLF FOR: 10		
BKSP	SAVE	CHG
<input type="text"/>	<input type="text"/>	<input type="text"/>

If there is a station 10 and it is not a DSS/BLF console

Press: **SAVE**

DSS/BLF FOR: 10		
BACK	NEXT	CHG
<input type="text"/>	<input type="text"/>	<input type="text"/>

**NOTE:** An owner of the DSS/BLF must exist and itself not be a DSS/BLF console.

**DEFAULT:** No DSS/BLF owner for all stations.

### 5.1.11 LEAST COST ROUTING (LCR) ENABLE

#### ACTION

#### RESULT

Press: **NEXT**

LCR ENABLE: N		
BACK	NEXT	CHG
<input type="text"/>	<input type="text"/>	<input type="text"/>

Y/N

Press: **CHG**

LCR ENABLE: Y		
BACK	NEXT	CHG
<input type="text"/>	<input type="text"/>	<input type="text"/>

**NOTE:** Station LCR ENABLE is associated with 'LCR'.

**DEFAULT:** All stations have 'LCR ENABLE: N'.

---

# SYSTEM PROGRAMMING .

## 5.4 SET CATEGORY

### 5.1.12 INTERCOM (ICM) TYPE

<u>ACTION</u>	<u>RESULT</u>										
Press: NEXT	<table border="1"><tr><td colspan="3">ICM TYPE: RING</td></tr><tr><td>BACK</td><td>NEXT</td><td>CHG</td></tr><tr><td><input type="text"/></td><td><input type="text"/></td><td><input type="text"/></td></tr></table>	ICM TYPE: RING			BACK	NEXT	CHG	<input type="text"/>	<input type="text"/>	<input type="text"/>	RING/VOICE
ICM TYPE: RING											
BACK	NEXT	CHG									
<input type="text"/>	<input type="text"/>	<input type="text"/>									
Press: CHG	<table border="1"><tr><td colspan="3">ICM TYPE: VOICE</td></tr><tr><td>BACK</td><td>NEXT</td><td>CHG</td></tr><tr><td><input type="text"/></td><td><input type="text"/></td><td><input type="text"/></td></tr></table>	ICM TYPE: VOICE			BACK	NEXT	CHG	<input type="text"/>	<input type="text"/>	<input type="text"/>	
ICM TYPE: VOICE											
BACK	NEXT	CHG									
<input type="text"/>	<input type="text"/>	<input type="text"/>									
Press: NEXT	<table border="1"><tr><td colspan="3">SHOW SET:</td></tr><tr><td>BKSP</td><td>SHOW</td><td>CHG</td></tr><tr><td><input type="text"/></td><td><input type="text"/></td><td><input type="text"/></td></tr></table>	SHOW SET:			BKSP	SHOW	CHG	<input type="text"/>	<input type="text"/>	<input type="text"/>	
SHOW SET:											
BKSP	SHOW	CHG									
<input type="text"/>	<input type="text"/>	<input type="text"/>									
Press: SHIFT	<table border="1"><tr><td colspan="3">1. SET</td></tr><tr><td>BACK</td><td>NEXT</td><td>SHOW</td></tr><tr><td><input type="text"/></td><td><input type="text"/></td><td><input type="text"/></td></tr></table>	1. SET			BACK	NEXT	SHOW	<input type="text"/>	<input type="text"/>	<input type="text"/>	
1. SET											
BACK	NEXT	SHOW									
<input type="text"/>	<input type="text"/>	<input type="text"/>									

NOTES: 1. Station ICM Type is associated with 'VOICE CALL'.

2. This programming item is only valid when a station has enabled 'Voice Call On'.

DEFAULT: All stations will ring when receiving an intercom call (ICM Type is 'RING').

# SYSTEM PROGRAMMING

## 5.2 LIME CATEGORY

### ACTION

### RESULT

Press: NEXT

2. LINE		
BACK	NEXT	SHOW
<input type="text"/>	<input type="text"/>	<input type="text"/>

Press: SHOW

SHOW LINE:		
BKSP	SHOW	CHG
<input type="text"/>	<input type="text"/>	<input type="text"/>

Press: 01

SHOW LINE: 01_		
BACK	SHOW	CHG
<input type="text"/>	<input type="text"/>	<input type="text"/>

01/02/..06

### 5.2.1 DAY CLASS, NIGHT CLASS (COS)

#### ACTION

#### RESULT

Press: SHOW

DAY CLASS: 0		
BACK	NEXT	CHG
<input type="text"/>	<input type="text"/>	<input type="text"/>

0/1/.../7

Press: CHG

DAY CLASS 1		
BACK	NEXT	CHG
<input type="text"/>	<input type="text"/>	<input type="text"/>

Press: NEXT

NIGHT CLASS: 0		
BACK	NEXT	CHG
<input type="text"/>	<input type="text"/>	<input type="text"/>

0/1/.../7

Press: CHG

NIGHT CLASS: 1		
BACK	NEXT	CHG
<input type="text"/>	<input type="text"/>	<input type="text"/>

- NOTES:**
1. Day/Night COS of line will be active according to the service mode in which the system is placed
  2. A line's COS is associated with the Toil Restriction feature.

**DEFAULT:** All lines have COS '0' Day and Night.

---

# SYSTEM PROGRAMMING

## 5.2 LINE CATEGORY, cont'd

### 5.2.2 DIALING TYPE SELECTION

<u>ACTION</u>	<u>RESULT</u>										
Press: NEXT	<table border="1"><tr><td colspan="3">DIALING: TONE</td></tr><tr><td>BACK</td><td>NEXT</td><td>CHG</td></tr><tr><td><input type="text"/></td><td><input type="text"/></td><td><input type="text"/></td></tr></table>	DIALING: TONE			BACK	NEXT	CHG	<input type="text"/>	<input type="text"/>	<input type="text"/>	TONE/PULSE
DIALING: TONE											
BACK	NEXT	CHG									
<input type="text"/>	<input type="text"/>	<input type="text"/>									
Press: CHG	<table border="1"><tr><td colspan="3">DIALING: PULSE</td></tr><tr><td>BACK</td><td>NEXT</td><td>CHG</td></tr><tr><td><input type="text"/></td><td><input type="text"/></td><td><input type="text"/></td></tr></table>	DIALING: PULSE			BACK	NEXT	CHG	<input type="text"/>	<input type="text"/>	<input type="text"/>	
DIALING: PULSE											
BACK	NEXT	CHG									
<input type="text"/>	<input type="text"/>	<input type="text"/>									

NOTE: To obtain a temporary Tone signal on a Pulse dialing line, press the '\*' key prior to the desired to digit(s).

DEFAULT: The dialing type of each line (pool) is tone dialing.

### 5.2.3 LINE TYPE

<u>ACTION</u>	<u>RESULT</u>										
Press: NEXT	<table border="1"><tr><td colspan="3">LINE TYPE: CO</td></tr><tr><td>BACK</td><td>NEXT</td><td>CHG</td></tr><tr><td><input type="text"/></td><td><input type="text"/></td><td><input type="text"/></td></tr></table>	LINE TYPE: CO			BACK	NEXT	CHG	<input type="text"/>	<input type="text"/>	<input type="text"/>	CO/PBX
LINE TYPE: CO											
BACK	NEXT	CHG									
<input type="text"/>	<input type="text"/>	<input type="text"/>									
Press: CHG	<table border="1"><tr><td colspan="3">LINE TYPE: PBX</td></tr><tr><td>BACK</td><td>NEXT</td><td>CHG</td></tr><tr><td><input type="text"/></td><td><input type="text"/></td><td><input type="text"/></td></tr></table>	LINE TYPE: PBX			BACK	NEXT	CHG	<input type="text"/>	<input type="text"/>	<input type="text"/>	
LINE TYPE: PBX											
BACK	NEXT	CHG									
<input type="text"/>	<input type="text"/>	<input type="text"/>									

NOTE: If a line is designed to -be connected behind PBX or CENTREX, the line type should be set to 'PBX' and the PBX line access codes must also be programmed (see System Programming Call Handling PBX code).

DEFAULT: All lines will be treated as if they were connected to Central Office (CO) directly.

# SYSTEM PROGRAMMING

## 5.2 LINE CATEGORY, cont'd

### 5.2.4 LINE POOL

ACTION

RESULT

Press: **NEXT**

LINE POOL: 1			(1 - 8)
BACK	NEXT	CHG	
_____	_____	_____	

Press: **CHG**

LINE POOL: 2			(1 - 8)
BACK	NEXT	CHG	
_____	_____	_____	

NOTE: The system provides eight line pools for flexible arrangement of C.O. line utilization.

DEFAULT: All lines belong to line pool 1.

### 5.2.5 PRIVATE LINE

ACTION

RESULT

Press: **NEXT**

PRIVATE TO: NONE				G
BACK	NEXT	C	H	
_____	_____	_____	_____	

Press: **CHG**

PRIVATE TO: _		
BKSP	SAVE	CHG
_____	_____	_____

Press: **10**

PRIVATE TO: 10			10 - 81, i.e, existing station number
BKSP	SAVE	CHG	
_____	_____	_____	

# SYSTEM PROGRAMMING

## 5.2 LINE CATEGORY, *cont'd*

<u>ACTION</u>	<u>RESULT</u>									
Press: <b>SAVE</b>	<table style="width: 100%; border-collapse: collapse;"> <tr> <td colspan="3">PRIVATE TO: 10</td> </tr> <tr> <td style="width: 33.33%;">BACK</td> <td style="width: 33.33%;">NEXT</td> <td style="width: 33.33%;">CHG</td> </tr> <tr> <td style="border: 1px solid black; height: 15px;"></td> <td style="border: 1px solid black; height: 15px;"></td> <td style="border: 1px solid black; height: 15px;"></td> </tr> </table>	PRIVATE TO: 10			BACK	NEXT	CHG			
PRIVATE TO: 10										
BACK	NEXT	CHG								

TO CANCEL:

Press: <b>CHG</b>	<table style="width: 100%; border-collapse: collapse;"> <tr> <td colspan="3">PRIVATE TO: <u>  </u></td> </tr> <tr> <td style="width: 33.33%;">BKSP</td> <td style="width: 33.33%;">SAVE</td> <td style="width: 33.33%;">CHG</td> </tr> <tr> <td style="border: 1px solid black; height: 15px;"></td> <td style="border: 1px solid black; height: 15px;"></td> <td style="border: 1px solid black; height: 15px;"></td> </tr> </table>	PRIVATE TO: <u>  </u>			BKSP	SAVE	CHG			
PRIVATE TO: <u>  </u>										
BKSP	SAVE	CHG								

Press: <b>SAVE</b>	<table style="width: 100%; border-collapse: collapse;"> <tr> <td colspan="3">PRIVATE TO: NONE</td> </tr> <tr> <td style="width: 33.33%;">BACK</td> <td style="width: 33.33%;">NEXT</td> <td style="width: 33.33%;">CHG</td> </tr> <tr> <td style="border: 1px solid black; height: 15px;"></td> <td style="border: 1px solid black; height: 15px;"></td> <td style="border: 1px solid black; height: 15px;"></td> </tr> </table>	PRIVATE TO: NONE			BACK	NEXT	CHG			
PRIVATE TO: NONE										
BACK	NEXT	CHG								

- NOTES:**
1. When a line is designated as a private line for one station, the programming status of **line/rin** assignment for that line will automatically be enabled for that station, but disabled for all other **sta**
  2. If the private line designation is removed, that line will automatically become accessible to all stations.

**DEFAULT:** No line is private to any station.

### 5.2.6 PRIVACY

<u>ACTION</u>	<u>RESULT</u>									
Press: <b>NEXT</b>	<table style="width: 100%; border-collapse: collapse;"> <tr> <td colspan="3">PRIVACY: Y</td> </tr> <tr> <td style="width: 33.33%;">BACK</td> <td style="width: 33.33%;">NEXT</td> <td style="width: 33.33%;">C H G</td> </tr> <tr> <td style="border: 1px solid black; height: 15px;"></td> <td style="border: 1px solid black; height: 15px;"></td> <td style="border: 1px solid black; height: 15px;"></td> </tr> </table>	PRIVACY: Y			BACK	NEXT	C H G			
PRIVACY: Y										
BACK	NEXT	C H G								

YIN

Press: <b>CHG</b>	<table style="width: 100%; border-collapse: collapse;"> <tr> <td colspan="3">PRIVACY: N</td> </tr> <tr> <td style="width: 33.33%;">BACK</td> <td style="width: 33.33%;">NEXT</td> <td style="width: 33.33%;">CHG</td> </tr> <tr> <td style="border: 1px solid black; height: 15px;"></td> <td style="border: 1px solid black; height: 15px;"></td> <td style="border: 1px solid black; height: 15px;"></td> </tr> </table>	PRIVACY: N			BACK	NEXT	CHG			
PRIVACY: N										
BACK	NEXT	CHG								

Allows multiple users to access the line simultaneously

**NOTE:** The privacy function is associated with the 'PRIVACY RELEASE' feature.

**DEFAULT:** The privacy function is enabled for all lines.

# SYSTEM PROGRAMMING,

## 5.2 LINE CATEGORY, cont'd

### 5.2.7 HUNT GROUP ANSWER

#### ACTION

#### RESULT

Press: **NEXT**

HUNT GROUP ANS		
BACK	NEXT	SHOW
_____	_____	_____

Press: **SHOW**

DAY MODE: N		
BACK	NEXT	CHG
_____	_____	_____

N, 1-6

Press: **CHG**

DAY MODE: 1		
BACK	NEXT	CHG
_____	_____	_____

This line will be answered by hunt group 1 when the system is in Day mode.

Press: **NEXT**

NIGHT MODE: N		
BACK	NEXT	CHG
_____	_____	_____

### 5.2.8 DELAYED RING

#### ACTION

#### RESULT

Press: **NEXT**

DELAYED RING		
BACK	NEXT	SHOW
_____	_____	_____

Press: **SHOW**

DELAY TIME: N		
BACK	NEXT	CHG
_____	_____	_____

Press: **CHG**

DELAY TIME: 10		
BACK	NEXT	CHG
_____	_____	_____

N/I 0/20/26/32 seconds

Press: **NEXT**

MAILBOX: EMPTY		
BACK	NEXT	CHG
_____	_____	_____

Press: **CHG**

MAILBOX:		
BKSP	SAVE	CHG
_____	_____	_____

# SYSTEM PROGRAMMING

## 5.2 LINE CATEGORY, cont'd

<u>ACTION</u>	<u>RESULT</u>							
Press: 327	<table border="1"><tr><td>MAILBOX: 327</td><td></td><td></td></tr><tr><td>BACK</td><td>NEXT</td><td>CHG</td></tr></table>	MAILBOX: 327			BACK	NEXT	CHG	
MAILBOX: 327								
BACK	NEXT	CHG						
Press: <b>NEXT</b>	<table border="1"><tr><td>REASON: N</td><td></td><td></td></tr><tr><td>BACK</td><td>NEXT</td><td>CHG</td></tr></table>	REASON: N			BACK	NEXT	CHG	Y/N
REASON: N								
BACK	NEXT	CHG						
Press: <b>CHG</b>	<table border="1"><tr><td>REASON: Y</td><td></td><td></td></tr><tr><td>BACK</td><td>NEXT</td><td>CHG</td></tr></table>	REASON: Y			BACK	NEXT	CHG	
REASON: Y								
BACK	NEXT	CHG						
Press: <b>NEXT</b>	<table border="1"><tr><td>ORIGINATOR: N</td><td></td><td></td></tr><tr><td>BACK</td><td>NEXT</td><td>CHG</td></tr></table>	ORIGINATOR: N			BACK	NEXT	CHG	Y/N
ORIGINATOR: N								
BACK	NEXT	CHG						
Press: <b>CHG</b>	<table border="1"><tr><td>ORIGINATOR: Y</td><td></td><td></td></tr><tr><td>BACK</td><td>NEXT</td><td>CHG</td></tr></table>	ORIGINATOR: Y			BACK	NEXT	CHG	
ORIGINATOR: Y								
BACK	NEXT	CHG						
Press: <b>NEXT</b>	<table border="1"><tr><td>DESTINATION</td><td></td><td></td></tr><tr><td>BACK</td><td>NEXT</td><td>SHOW</td></tr></table>	DESTINATION			BACK	NEXT	SHOW	
DESTINATION								
BACK	NEXT	SHOW						
Press: <b>SHOW</b>	<table border="1"><tr><td>FIRST: NONE</td><td></td><td></td></tr><tr><td>BACK</td><td>NEXT</td><td>CHG</td></tr></table>	FIRST: NONE			BACK	NEXT	CHG	
FIRST: NONE								
BACK	NEXT	CHG						
Press: <b>CHG</b>	<table border="1"><tr><td>FIRST:</td><td></td><td></td></tr><tr><td>BKSP</td><td>SAVE</td><td>CHG</td></tr></table>	FIRST:			BKSP	SAVE	CHG	10 - 81, existing set number, or 82 - 89, hunt group number
FIRST:								
BKSP	SAVE	CHG						

# SYSTEM PROGRAMMING

## 5.2 LINE CAT&GORY, cont'd

<u>ACTION</u>	<u>RESULT</u>	
Press: 10	FIRST: 10 BKSP    SAVE    CHG <input style="width: 50px; height: 15px; margin: 2px 0;" type="text"/> <input style="width: 50px; height: 15px; margin: 2px 0;" type="text"/> <input style="width: 50px; height: 15px; margin: 2px 0;" type="text"/>	
Press: <b>SAVE</b>	FIRST: 10 BACK    NEXT    CHG <input style="width: 50px; height: 15px; margin: 2px 0;" type="text"/> <input style="width: 50px; height: 15px; margin: 2px 0;" type="text"/> <input style="width: 50px; height: 15px; margin: 2px 0;" type="text"/>	
Press: NEXT	SECOND: NONE BACK    NEXT    CHG <input style="width: 50px; height: 15px; margin: 2px 0;" type="text"/> <input style="width: 50px; height: 15px; margin: 2px 0;" type="text"/> <input style="width: 50px; height: 15px; margin: 2px 0;" type="text"/>	
Press: <b>CHG</b>	SECOND: BKSP <u>  </u> SAVE    CHG <input style="width: 50px; height: 15px; margin: 2px 0;" type="text"/> <input style="width: 50px; height: 15px; margin: 2px 0;" type="text"/> <input style="width: 50px; height: 15px; margin: 2px 0;" type="text"/>	10 * 81, existing set number, or 82 - 89, hunt group number
Press: 20	SECOND: 20 BKSP    SAVE    CHG <input style="width: 50px; height: 15px; margin: 2px 0;" type="text"/> <input style="width: 50px; height: 15px; margin: 2px 0;" type="text"/> <input style="width: 50px; height: 15px; margin: 2px 0;" type="text"/>	
Press: <b>SAVE</b>	SECOND: 20 BACK    NEXT    CHG <input style="width: 50px; height: 15px; margin: 2px 0;" type="text"/> <input style="width: 50px; height: 15px; margin: 2px 0;" type="text"/> <input style="width: 50px; height: 15px; margin: 2px 0;" type="text"/>	
Press: NEXT	SHOW LINE: <u>  </u> BKSP    SHOW    CHG <input style="width: 50px; height: 15px; margin: 2px 0;" type="text"/> <input style="width: 50px; height: 15px; margin: 2px 0;" type="text"/> <input style="width: 50px; height: 15px; margin: 2px 0;" type="text"/>	01 -06
Press: <b>SHIFT</b> key	2. LINE BACK    NEXT    SHOW <input style="width: 50px; height: 15px; margin: 2px 0;" type="text"/> <input style="width: 50px; height: 15px; margin: 2px 0;" type="text"/> <input style="width: 50px; height: 15px; margin: 2px 0;" type="text"/>	

NOTE: The station ring assignment will be followed if the programmed hunt group has no member.

---

# SYSTEM PROGRAMMING

## 5.3 CALL HANDLING CATEGORY

### ACTION

### RESULT

Press: **NEXT**

3. CALL HANDLING		
BACK	NEXT	SHOW
_____	_____	_____

### 5.3.1 FLASH TIME

### ACTION

### RESULT

Press: **SHOW**

FLASH TIME: 0.6		
BACK	NEXT	CHG
_____	_____	_____

0.1/0.2/.../1.5 seconds

Press: **CHG**

FLASH TIME: 0.7		
BACK	NEXT	CHG
_____	_____	_____

**NOTE:** The flash operation is used to invoke certain functions which are provided by the Central Office, CENTREX, or PBX.

**DEFAULT:** The flash time is 0.6 seconds.

### 5.3.2 RECALL RINGS

### ACTION

### RESULT

Press: **NEXT**

RECALL RINGS: 3		
BACK	NEXT	CHG
_____	_____	_____

1/2/.../8 rings

Press: **CHG**

RECALL RINGS: 4		
BACK	NEXT	CHG
_____	_____	_____

1/2/.../8 rings

# SYSTEM PROGRAMMING

## 5.3 CALL HANDLING CATEGORY, cont'd

**NOTE:** Programmed recall rings are used for unscreened line call transfer. If the transferred call is not answered within the programmed number of rings, it will recall to the original station. If this call is still not answered by the original station within the programmed number of rings, it will then recall to the attendant. If there is no answer at the attendant within the programmed number of rings, the call will become common hold.

**DEFAULT:** The default number of recall rings is three rings.

### 5.3.3 PAUSE TIME

<u>ACTION</u>	<u>RESULT</u>							
Press: <b>NEXT</b>	<table border="1"><tr><td>PAUSE TIME: 2</td><td></td><td></td></tr><tr><td>BACK</td><td>NEXT</td><td>CHG</td></tr></table>	PAUSE TIME: 2			BACK	NEXT	CHG	1.5/2/3.5/5 seconds
PAUSE TIME: 2								
BACK	NEXT	CHG						
Press: <b>CHG</b>	<table border="1"><tr><td>PAUSE TIME: 3.5</td><td></td><td></td></tr><tr><td>BACK</td><td>NEXT</td><td>CHG</td></tr></table>	PAUSE TIME: 3.5			BACK	NEXT	CHG	1.5/2/3.5/5 seconds
PAUSE TIME: 3.5								
BACK	NEXT	CHG						

**NOTE:** The pause operation is used to stop dialing temporarily, waiting for a response or further processing from the Central Office, in order to carry out certain feature applications.

**DEFAULT:** The pause time is two seconds.

### 5.3.4 PBX CODE

<u>ACTION</u>	<u>RESULT</u>							
Press: <b>NEXT</b>	<table border="1"><tr><td>PBX CODE: 9</td><td></td><td></td></tr><tr><td>BACK</td><td>NEXT</td><td>CHG</td></tr></table>	PBX CODE: 9			BACK	NEXT	CHG	
PBX CODE: 9								
BACK	NEXT	CHG						
Press: <b>CHG</b>	<table border="1"><tr><td>PBX CODE: _</td><td></td><td></td></tr><tr><td>BKSP</td><td>SAVE</td><td>CHG</td></tr></table>	PBX CODE: _			BKSP	SAVE	CHG	(0-9 or 00-99)
PBX CODE: _								
BKSP	SAVE	CHG						

# SYSTEM PROGRAMMING

## 5.3 CALL HANDLING, cont'd

<u>ACTION</u>	<u>RESULT</u>							
Press: 90	<table border="1"><tr><td colspan="3">PBX CODE: 90</td></tr><tr><td>BKSP</td><td>SAVE</td><td>CHG</td></tr></table>	PBX CODE: 90			BKSP	SAVE	CHG	
PBX CODE: 90								
BKSP	SAVE	CHG						
Press: <b>SAVE</b>	<table border="1"><tr><td colspan="3">PBX CODE: 90</td></tr><tr><td>BACK</td><td>NEXT</td><td>CHG</td></tr></table>	PBX CODE: 90			BACK	NEXT	CHG	Two-digit; programming
PBX CODE: 90								
BACK	NEXT	CHG						
Press: <b>CHG</b>	<table border="1"><tr><td colspan="3">PBX CODE: _</td></tr><tr><td>BKSP</td><td>SAVE</td><td>CHG</td></tr></table>	PBX CODE: _			BKSP	SAVE	CHG	
PBX CODE: _								
BKSP	SAVE	CHG						
Press: 0	<table border="1"><tr><td colspan="3">PBX CODE: 0</td></tr><tr><td>BKSP</td><td>SAVE</td><td>CHG</td></tr></table>	PBX CODE: 0			BKSP	SAVE	CHG	
PBX CODE: 0								
BKSP	SAVE	CHG						
Press: <b>SAVE</b>	<table border="1"><tr><td colspan="3">PBX CODE: 0</td></tr><tr><td>BACK</td><td>NEXT</td><td>CHG</td></tr></table>	PBX CODE: 0			BACK	NEXT	CHG	One-digit programming
PBX CODE: 0								
BACK	NEXT	CHG						

- NOTES:**
1. PBX access codes can be assigned as either a one digit code from 0 to 9, or a 2 digit code from 00 to 99.
  2. After the PBX access code is dialed, a fixed pause time of one second will be automatically inserted in order to achieve real C.O. dial tone before dialing subsequent digits.

**DEFAULT:** The initial PBX access code is one digit, '9'.

### 5.3.5 TONE DURATION

<u>ACTION</u>	<u>RESULT</u>							
Press: <b>NEXT</b>	<table border="1"><tr><td colspan="3">TONE TIME: 120</td></tr><tr><td>BACK</td><td>NEXT</td><td>CHG</td></tr></table>	TONE TIME: 120			BACK	NEXT	CHG	70/120/150 msec
TONE TIME: 120								
BACK	NEXT	CHG						

# SYSTEM PROGRAMMING

## 5.3 CALL HANDLING CATEGORY, cont'd

<u>ACTION</u>	<u>RESULT</u>									
press: <b>CHG</b>	<table border="1"><tr><td colspan="3">TONE TIME: 150</td></tr><tr><td>BACK</td><td>NEXT</td><td>CHG</td></tr></table> <table><tr><td>_____</td><td>_____</td><td>_____</td></tr></table>	TONE TIME: 150			BACK	NEXT	CHG	_____	_____	_____
TONE TIME: 150										
BACK	NEXT	CHG								
_____	_____	_____								

70/120/150 msec

**NOTE:** In order to be more compatible with the connected switching system, the user may pick the most suitable tone duration to send the tone digit signal.

**DEFAULT:** The tone signal sending duration for digit dialing is 120 milliseconds.

## 5.3.6 LONG TONES

<u>ACTION</u>	<u>RESULT</u>									
Press: <b>NEXT</b>	<table border="1"><tr><td colspan="3">LONG TONES: 1400</td></tr><tr><td>BACK</td><td>NEXT</td><td>CHG</td></tr></table> <table><tr><td>_____</td><td>_____</td><td>_____</td></tr></table>	LONG TONES: 1400			BACK	NEXT	CHG	_____	_____	_____
LONG TONES: 1400										
BACK	NEXT	CHG								
_____	_____	_____								
Press: <b>CHG</b>	<table border="1"><tr><td colspan="3">LONG TONES: 1500</td></tr><tr><td>BACK</td><td>NEXT</td><td>CHG</td></tr></table> <table><tr><td>_____</td><td>_____</td><td>_____</td></tr></table>	LONG TONES: 1500			BACK	NEXT	CHG	_____	_____	_____
LONG TONES: 1500										
BACK	NEXT	CHG								
_____	_____	_____								

200/300/.../1500 msec

200/300/.../1500 msec

**NOTES:** 1. In order to activate the service functions at the remote device, e.g. the voice mail system, the user may pick a suitable long DTMF tone duration to send tone digit signal.

2. Long tones can be enabled by pressing F72.

**DEFAULT:** The long tones duration is 1400 milliseconds.

# SYSTEM PROGRAMMING-

## 5.3 CALL HANDLING CATEGORY, cont'd

### 5.3.7 VOICE MAIL HEADER TIMING

<u>ACTION</u>	<u>RESULT</u>	
Press: <b>NEXT</b>	VM HEADER TIMING BACK    NEXT    SHOW <hr style="border: none; border-top: 1px solid black; margin: 2px 0;"/>	
Press: <b>SHOW</b>	90/120/150 TONE ON: 120 BACK    NEXT    CHG <hr style="border: none; border-top: 1px solid black; margin: 2px 0;"/>	msec
Press: <b>NEXT</b>	TONE OFF: 120 BACK    NEXT    CHG <hr style="border: none; border-top: 1px solid black; margin: 2px 0;"/>	90/120/150 msec

**NOTE:** In order to activate the provided service functions of the voice mail system, the user may pick a suitable DTMF tone duration to send a tone digit signal.

**DEFAULT:** The 'TONE ON' and 'TONE OFF' duration for digit dialing is 120 milliseconds.

### 5.3.8 BOSS/SECRETARY PROGRAMMING

<u>ACTION</u>	<u>RESULT</u>	
Press: <b>NEXT</b>	BOSS/SECRETARY BACK    NEXT    SHOW <hr style="border: none; border-top: 1px solid black; margin: 2px 0;"/>	
Press: <b>SHOW</b>	SECRETARY: BKSP <u>  </u> SHŌW    CHG <hr style="border: none; border-top: 1px solid black; margin: 2px 0;"/>	
Press: <b>10</b>	SECRETARY: 10 <b>1</b> BKSP    SHŌW    CHG <hr style="border: none; border-top: 1px solid black; margin: 2px 0;"/>	10-81, i.e., existing station num

# SYSTEM PROGRAMMING

## 5.3 CALL HANDLING CATEGORY, cont'd

<u>ACTION</u>	<u>RESULT</u>									
Press: <b>SHOW</b>	<table border="1"><tr><td colspan="3">BOSS 1: NONE</td></tr><tr><td>BACK</td><td>NEXT</td><td>CHG</td></tr><tr><td><input type="text"/></td><td><input type="text"/></td><td><input type="text"/></td></tr></table>	BOSS 1: NONE			BACK	NEXT	CHG	<input type="text"/>	<input type="text"/>	<input type="text"/>
BOSS 1: NONE										
BACK	NEXT	CHG								
<input type="text"/>	<input type="text"/>	<input type="text"/>								
Press: <b>NEXT</b>	<table border="1"><tr><td colspan="3">BOSS 2: NONE</td></tr><tr><td>BACK</td><td>NEXT</td><td>CHG</td></tr><tr><td><input type="text"/></td><td><input type="text"/></td><td><input type="text"/></td></tr></table>	BOSS 2: NONE			BACK	NEXT	CHG	<input type="text"/>	<input type="text"/>	<input type="text"/>
BOSS 2: NONE										
BACK	NEXT	CHG								
<input type="text"/>	<input type="text"/>	<input type="text"/>								
Press: <b>CHG</b>	<table border="1"><tr><td colspan="3">BOSS 2: _</td></tr><tr><td>BKSP</td><td>SAVE</td><td>CHG</td></tr><tr><td><input type="text"/></td><td><input type="text"/></td><td><input type="text"/></td></tr></table>	BOSS 2: _			BKSP	SAVE	CHG	<input type="text"/>	<input type="text"/>	<input type="text"/>
BOSS 2: _										
BKSP	SAVE	CHG								
<input type="text"/>	<input type="text"/>	<input type="text"/>								
Press: 16	<table border="1"><tr><td colspan="3">BOSS 2: 16</td></tr><tr><td>BKSP</td><td>SAVE</td><td>CHG</td></tr><tr><td><input type="text"/></td><td><input type="text"/></td><td><input type="text"/></td></tr></table> 10-81, i.e., existing station number	BOSS 2: 16			BKSP	SAVE	CHG	<input type="text"/>	<input type="text"/>	<input type="text"/>
BOSS 2: 16										
BKSP	SAVE	CHG								
<input type="text"/>	<input type="text"/>	<input type="text"/>								
Press: <b>SAVE</b>	<table border="1"><tr><td colspan="3">BOSS 2: 16</td></tr><tr><td>BACK</td><td>NEXT</td><td>CHG</td></tr><tr><td><input type="text"/></td><td><input type="text"/></td><td><input type="text"/></td></tr></table>	BOSS 2: 16			BACK	NEXT	CHG	<input type="text"/>	<input type="text"/>	<input type="text"/>
BOSS 2: 16										
BACK	NEXT	CHG								
<input type="text"/>	<input type="text"/>	<input type="text"/>								
Press: <b>NEXT</b>	<table border="1"><tr><td colspan="3">SECRETARY: _</td></tr><tr><td>BKSP</td><td>SHOW</td><td>CHG</td></tr><tr><td><input type="text"/></td><td><input type="text"/></td><td><input type="text"/></td></tr></table>	SECRETARY: _			BKSP	SHOW	CHG	<input type="text"/>	<input type="text"/>	<input type="text"/>
SECRETARY: _										
BKSP	SHOW	CHG								
<input type="text"/>	<input type="text"/>	<input type="text"/>								
Press: <b>SHIFT</b>										

**NOTE:** 1. Any station which is assigned as a secretary can simultaneously serve, at most, two stations.

2. The secretary station can override the boss station(s) where DND is enabled.

**DEFAULT:** No relationship of boss and secretary is established for any station,

---

# SYSTEM PROGRAMMING

## 5.3 CALL HANDLING CATEGORY, cont'd

### 5.3.9 DIRECT INWARD SYSTEM ACCESS (DISA)

ACTION	RESULT									
Press: <b>NEXT</b>	<table border="1"><tr><td>DISA</td><td></td><td></td></tr><tr><td>BACK</td><td>NEXT</td><td>SHOW</td></tr><tr><td><input type="text"/></td><td><input type="text"/></td><td><input type="text"/></td></tr></table>	DISA			BACK	NEXT	SHOW	<input type="text"/>	<input type="text"/>	<input type="text"/>
DISA										
BACK	NEXT	SHOW								
<input type="text"/>	<input type="text"/>	<input type="text"/>								
Press: <b>SHOW</b>	<table border="1"><tr><td>ACTIVE LINE: _</td><td></td><td></td></tr><tr><td>BKSP</td><td>SHOW</td><td>CHG</td></tr><tr><td><input type="text"/></td><td><input type="text"/></td><td><input type="text"/></td></tr></table>	ACTIVE LINE: _			BKSP	SHOW	CHG	<input type="text"/>	<input type="text"/>	<input type="text"/>
ACTIVE LINE: _										
BKSP	SHOW	CHG								
<input type="text"/>	<input type="text"/>	<input type="text"/>								
Press: <b>01</b>	<table border="1"><tr><td>ACTIVE LINE: 01</td><td></td><td></td></tr><tr><td>BKSP</td><td>SHOW</td><td>CHG</td></tr><tr><td><input type="text"/></td><td><input type="text"/></td><td><input type="text"/></td></tr></table> (01 - 06)	ACTIVE LINE: 01			BKSP	SHOW	CHG	<input type="text"/>	<input type="text"/>	<input type="text"/>
ACTIVE LINE: 01										
BKSP	SHOW	CHG								
<input type="text"/>	<input type="text"/>	<input type="text"/>								
Press: <b>SHOW</b>	<table border="1"><tr><td>DISA LINE: N</td><td></td><td></td></tr><tr><td>BACK</td><td>NEXT</td><td>CHG</td></tr><tr><td><input type="text"/></td><td><input type="text"/></td><td><input type="text"/></td></tr></table> Y/N	DISA LINE: N			BACK	NEXT	CHG	<input type="text"/>	<input type="text"/>	<input type="text"/>
DISA LINE: N										
BACK	NEXT	CHG								
<input type="text"/>	<input type="text"/>	<input type="text"/>								
Press: <b>CHG</b>	<table border="1"><tr><td>DISA LINE: Y</td><td></td><td></td></tr><tr><td>BACK</td><td>NEXT</td><td>CHG</td></tr><tr><td><input type="text"/></td><td><input type="text"/></td><td><input type="text"/></td></tr></table> Y/N	DISA LINE: Y			BACK	NEXT	CHG	<input type="text"/>	<input type="text"/>	<input type="text"/>
DISA LINE: Y										
BACK	NEXT	CHG								
<input type="text"/>	<input type="text"/>	<input type="text"/>								
Press: <b>NEXT</b>	<table border="1"><tr><td>SERVICE: DAY</td><td></td><td></td></tr><tr><td>BACK</td><td>NEXT</td><td>CHG</td></tr><tr><td><input type="text"/></td><td><input type="text"/></td><td><input type="text"/></td></tr></table> DAY/NIGHT/ALWAYS	SERVICE: DAY			BACK	NEXT	CHG	<input type="text"/>	<input type="text"/>	<input type="text"/>
SERVICE: DAY										
BACK	NEXT	CHG								
<input type="text"/>	<input type="text"/>	<input type="text"/>								
Press: <b>CHG</b>	<table border="1"><tr><td>SERVICE: NIGHT</td><td></td><td></td></tr><tr><td>BACK</td><td>NEXT</td><td>CHG</td></tr><tr><td><input type="text"/></td><td><input type="text"/></td><td><input type="text"/></td></tr></table> DAY/NIGHT/ALWAYS	SERVICE: NIGHT			BACK	NEXT	CHG	<input type="text"/>	<input type="text"/>	<input type="text"/>
SERVICE: NIGHT										
BACK	NEXT	CHG								
<input type="text"/>	<input type="text"/>	<input type="text"/>								
Press: <b>NEXT</b>	<table border="1"><tr><td>DISA RINGS: 1</td><td></td><td></td></tr><tr><td>BACK</td><td>NEXT</td><td>CHG</td></tr><tr><td><input type="text"/></td><td><input type="text"/></td><td><input type="text"/></td></tr></table> (1 - 5)	DISA RINGS: 1			BACK	NEXT	CHG	<input type="text"/>	<input type="text"/>	<input type="text"/>
DISA RINGS: 1										
BACK	NEXT	CHG								
<input type="text"/>	<input type="text"/>	<input type="text"/>								

# SYSTEM PROGRAMMING .

## 5.3 CALL HANDLING, cont'd

### ACTION

### RESULT

press: CHG

DISA RINGS: 2		
BACK	NEXT	CHG
_____	_____	_____

press: NEXT

ACTIVE LINE: _		
BKSP	SHOW	CHG
_____	_____	_____

(01 \* 06)

Press: SHIFT

DISA		
BACK	NEXT	SHOW
_____	_____	_____

### 5.3.10 DISA ACCESS CODE

Press: NEXT

DISA ACCESS CODE		
BACK	NEXT	SHOW
_____	_____	_____

Press: SHOW

01. EMPTY		
BACK	NEXT	CHG
_____	_____	_____

Press: CHG

01. _		
BKSP	SAVE	CHG
_____	_____	_____

9 digits

Press: 123456780

01. 123456780		
BKSP	SAVE	CHG
_____	_____	_____

'12345678' is- the password,  
the ninth digit, '0', is the COS

Press: SAVE

01. 123456780		
BACK	NEXT	CHG
_____	_____	_____

---

# SYSTEM PROGRAMMING

## 5.3 CALL HANDLING CATEGORY, cont'd

### ACTION

### RESULT

Press: **NEXT**

02. EMPTY		
BACK	NEXT	CHG
<input type="text"/>	<input type="text"/>	<input type="text"/>

Press: **NEXT**

24. EMPTY		
BACK	NEXT	CHG
<input type="text"/>	<input type="text"/>	<input type="text"/>

- NOTES:**
1. You can program all twelve lines to be DISA lines, but at most only 2 lines can be activate the DISA function at the same time.
  2. If one line is used by the external party through the DISA function, toll restriction will be e according to the COS of the outgoing line and the entered password.
  3. Even if the DISA function is assigned to a specific line, the activation is still based on the nated system service time/mode.
  4. When the conversation time is about to expire, the external party may press the '\*\*' key to a new conversation time.
  5. If the conversation time limit (15 minutes) has not yet expired when the conversation is fin the external party must dial '\*9' to release the line if Loop Break Detection is not enabled.
  6. Refer to the 'Feature Operation User Guide' for more detail.
  7. The 9th digit in the DISA access code is the COS which is used for toll restriction.

- DEFAULT:**
1. Each line does not work for the DISA function.
  2. The default ring count before obtaining the special dial tone is one ring.
  3. DISA service mode is 'DAY'.
  4. DISA access codes are empty.

### 5.3.11 EXTERNAL CALL FORWARD (ECF)

#### ACTION

#### RESULT

Press: **NEXT**

EXTERNAL CFW		
BACK	NEXT	SHOW
<input type="text"/>	<input type="text"/>	<input type="text"/>

# SYSTEM PROGRAMMING

## 5.3 CALL HANDLING CATEGORY, cont'd

<u>ACTION</u>	<u>RESULT</u>										
Press: <b>SHOW</b>	<table border="1"><tr><td>ACTIVE LINE: _</td><td></td><td></td></tr><tr><td>BKSP</td><td>SHOW</td><td>CHG</td></tr><tr><td>_____</td><td>_____</td><td>_____</td></tr></table>	ACTIVE LINE: _			BKSP	SHOW	CHG	_____	_____	_____	(01 - 06)
ACTIVE LINE: _											
BKSP	SHOW	CHG									
_____	_____	_____									
Press: <b>02</b>	<table border="1"><tr><td>ACTIVE LINE: 02</td><td></td><td></td></tr><tr><td>BKSP</td><td>SHOW</td><td>CHG</td></tr><tr><td>_____</td><td>_____</td><td>_____</td></tr></table>	ACTIVE LINE: 02			BKSP	SHOW	CHG	_____	_____	_____	
ACTIVE LINE: 02											
BKSP	SHOW	CHG									
_____	_____	_____									
Press: <b>SHOW</b>	<table border="1"><tr><td>TYPE: NONE</td><td></td><td></td></tr><tr><td>BACK</td><td>NEXT</td><td>CHG</td></tr><tr><td>_____</td><td>_____</td><td>_____</td></tr></table>	TYPE: NONE			BACK	NEXT	CHG	_____	_____	_____	NONE/INCOMING/OUTGOING
TYPE: NONE											
BACK	NEXT	CHG									
_____	_____	_____									
Press: <b>CHG</b>	<table border="1"><tr><td>TYPE: INCOMING</td><td></td><td></td></tr><tr><td>BACK</td><td>NEXT</td><td>CHG</td></tr><tr><td>_____</td><td>_____</td><td>_____</td></tr></table>	TYPE: INCOMING			BACK	NEXT	CHG	_____	_____	_____	NONE/INCOMING/OUTGOING
TYPE: INCOMING											
BACK	NEXT	CHG									
_____	_____	_____									
Press: <b>NEXT</b>	<table border="1"><tr><td>SERVICE: DAY</td><td></td><td></td></tr><tr><td>BACK</td><td>NEXT</td><td>CHG</td></tr><tr><td>_____</td><td>_____</td><td>_____</td></tr></table>	SERVICE: DAY			BACK	NEXT	CHG	_____	_____	_____	DAY/NIGHT/ALWAYS
SERVICE: DAY											
BACK	NEXT	CHG									
_____	_____	_____									
Press: <b>NEXT</b>	<table border="1"><tr><td>ACTIVE LINE: _</td><td></td><td></td></tr><tr><td>BKSP</td><td>SHOW</td><td>CHG</td></tr><tr><td>_____</td><td>_____</td><td>_____</td></tr></table>	ACTIVE LINE: _			BKSP	SHOW	CHG	_____	_____	_____	
ACTIVE LINE: _											
BKSP	SHOW	CHG									
_____	_____	_____									
Press: <b>SHIFT</b> key	<table border="1"><tr><td>EXTERNAL CFW</td><td></td><td></td></tr><tr><td>BACK</td><td>NEXT</td><td>SHOW</td></tr><tr><td>_____</td><td>_____</td><td>_____</td></tr></table>	EXTERNAL CFW			BACK	NEXT	SHOW	_____	_____	_____	
EXTERNAL CFW											
BACK	NEXT	SHOW									
_____	_____	_____									

- NOTES:**
1. When incoming and outgoing ECF lines are programmed, the system SPD # '99' must also be programmed.
  2. When one incoming ECF line is signaling, the system will answer it and then occupy one outgoing ECF line to dial the number which is stored in SPD location '99'.
  3. If the conversation time (7 minutes) has not yet expired, but the conversation has finished, the calling or called party must dial '\*9' to release the line if Loop Break Detection is not enabled.

# SYSTEM PROGRAMMING

## 5.3 CALL HANDLING CATEGORY, cont'd

- NOTES:** 4. When one incoming ECF line is signaling, but the outgoing ECF is either busy or the SPD is empty, then the system will not answer the call.  
5. Refer to 'Feature Operation User Guide' for more details.

**DEFAULT:** No line is assigned as an incoming ECF line or an outgoing ECF line.

### 5.3.12 AUTOMATIC BUSY REDIAL (ABR)

<u>ACTION</u>	<u>RESULT</u>												
Press: <b>NEXT</b>	<table border="1"><tr><td colspan="3">AUTO BUSY REDIAL</td></tr><tr><td>BACK</td><td>NEXT</td><td>SHOW</td></tr><tr><td><input type="text"/></td><td><input type="text"/></td><td><input type="text"/></td></tr></table>	AUTO BUSY REDIAL			BACK	NEXT	SHOW	<input type="text"/>	<input type="text"/>	<input type="text"/>			
AUTO BUSY REDIAL													
BACK	NEXT	SHOW											
<input type="text"/>	<input type="text"/>	<input type="text"/>											
Press: <b>SHOW</b>	<table border="1"><tr><td colspan="3">ABR REPEAT: 5</td></tr><tr><td>BACK</td><td>NEXT</td><td>CHG</td></tr><tr><td><input type="text"/></td><td><input type="text"/></td><td><input type="text"/></td></tr></table> NONE/ 1-15	ABR REPEAT: 5			BACK	NEXT	CHG	<input type="text"/>	<input type="text"/>	<input type="text"/>			
ABR REPEAT: 5													
BACK	NEXT	CHG											
<input type="text"/>	<input type="text"/>	<input type="text"/>											
Press: <b>NEXT</b>	<table border="1"><tr><td colspan="3">10/30/60/90/120</td></tr><tr><td colspan="3">ABR INTERVAL: 60</td></tr><tr><td>BACK</td><td>NEXT</td><td>CHG</td></tr><tr><td><input type="text"/></td><td><input type="text"/></td><td><input type="text"/></td></tr></table> seconds	10/30/60/90/120			ABR INTERVAL: 60			BACK	NEXT	CHG	<input type="text"/>	<input type="text"/>	<input type="text"/>
10/30/60/90/120													
ABR INTERVAL: 60													
BACK	NEXT	CHG											
<input type="text"/>	<input type="text"/>	<input type="text"/>											

**NOTE:** If the 'ABR REPEAT' is set to '0', then the ABR function is suppressed.

**DEFAULT:** ABR repetition is 5, the ABR interval is 60 seconds.

### 5.3.13 DSS/SPD FUNCTION KEY PRIORITY

<u>ACTION</u>	<u>RESULT</u>									
Press: <b>NEXT</b>	<table border="1"><tr><td colspan="3">KEY PRIORITY: SPD</td></tr><tr><td>BACK</td><td>NEXT</td><td>CHG</td></tr><tr><td><input type="text"/></td><td><input type="text"/></td><td><input type="text"/></td></tr></table> SPD/DSS	KEY PRIORITY: SPD			BACK	NEXT	CHG	<input type="text"/>	<input type="text"/>	<input type="text"/>
KEY PRIORITY: SPD										
BACK	NEXT	CHG								
<input type="text"/>	<input type="text"/>	<input type="text"/>								

# SYSTEM PROGRAMMING

## 5.3 CALL HANDLING CATEGORY, cont'd

<u>ACTION</u>	<u>RESULT</u>									
Press: <b>CHG</b>	<table border="1"><tr><td colspan="3">KEY PRIORITY: DSS</td></tr><tr><td>BACK</td><td>NEXT</td><td>CHG</td></tr><tr><td>_____</td><td>_____</td><td>_____</td></tr></table>	KEY PRIORITY: DSS			BACK	NEXT	CHG	_____	_____	_____
KEY PRIORITY: DSS										
BACK	NEXT	CHG								
_____	_____	_____								

**DEFAULT:** The SPD function has priority over the DSS function.

### 5.3.14 ONE TOUCH TRANSFER (XFR)

<u>ACTION</u>	<u>RESULT</u>										
Press: <b>NEXT</b>	<table border="1"><tr><td colspan="3">ONE TOUCH XFR: N</td></tr><tr><td>BACK</td><td>NEXT</td><td>CHG</td></tr><tr><td>_____</td><td>_____</td><td>_____</td></tr></table>	ONE TOUCH XFR: N			BACK	NEXT	CHG	_____	_____	_____	Y/N
ONE TOUCH XFR: N											
BACK	NEXT	CHG									
_____	_____	_____									
Press: <b>CHG</b>	<table border="1"><tr><td colspan="3">ONE TOUCH XFR: Y</td></tr><tr><td>BACK</td><td>NEXT</td><td>CHG</td></tr><tr><td>_____</td><td>_____</td><td>_____</td></tr></table>	ONE TOUCH XFR: Y			BACK	NEXT	CHG	_____	_____	_____	
ONE TOUCH XFR: Y											
BACK	NEXT	CHG									
_____	_____	_____									

**DEFAULT:** One Touch XFR is 'N'.

### 5.3.15 SUPERVISED TRANSFER (XFR) TYPE

<u>ACTION</u>	<u>RESULT</u>										
Press: <b>NEXT</b>	<table border="1"><tr><td colspan="3">SUPERVISED XFR</td></tr><tr><td>BACK</td><td>NEXT</td><td>SHOW</td></tr><tr><td>_____</td><td>_____</td><td>_____</td></tr></table>	SUPERVISED XFR			BACK	NEXT	SHOW	_____	_____	_____	
SUPERVISED XFR											
BACK	NEXT	SHOW									
_____	_____	_____									
Press: <b>SHOW</b>	<table border="1"><tr><td colspan="3">RING ON XFR: N</td></tr><tr><td>BACK</td><td>NEXT</td><td>CHG</td></tr><tr><td>_____</td><td>_____</td><td>_____</td></tr></table>	RING ON XFR: N			BACK	NEXT	CHG	_____	_____	_____	Y/N
RING ON XFR: N											
BACK	NEXT	CHG									
_____	_____	_____									

---

# SYSTEM PROGRAMMING

## 5.3 CALL HANDLING CATEGORY, cont'd

ACTION

RESULT

Press: **CHG**

RING ON XFR: Y		
BACK	NEXT	CHG
<input type="checkbox"/>	<input type="checkbox"/>	<input type="checkbox"/>

**DEFAULT:** 'RING ON XFR' is 'N'.

### 5.3.16 RING ON TALK

ACTION

RESULT

Press: **NEXT**

RING ON TALK: N		
BACK	NEXT	CHG
<input type="checkbox"/>	<input type="checkbox"/>	<input type="checkbox"/>

YIN

Press: **CHG**

RING ON TALK: Y		
BACK	NEXT	CHG
<input type="checkbox"/>	<input type="checkbox"/>	<input type="checkbox"/>

**DEFAULT:** 'RING ON TALK' is 'N'.

# SYSTEM PROGRAMMING

## 5.4 RESOURCE CATEGORY

### ACTION

### RESULT

Press: NEXT

4. RESOURCE		
BACK	NEXT	SHOW
_____	_____	_____

### 5.4.1 SYSTEM ALARM

### ACTION

### RESULT

Press: SHOW

SYSTEM ALARM		
BACK	NEXT	SHOW
_____	_____	_____

Press: SHOW

ALARM 1: NONE		
BACK	NEXT	CHG
_____	_____	_____

If inactive

OR,

ALARM 1: 12:30		
BACK	NEXT	CHG
_____	_____	_____

If not empty

Press: CHG

ALARM 1: _		
BKSP	SAVE	CHG
_____	_____	_____

Press: SAVE

ALARM 1: NONE		
BACK	NEXT	CHG
_____	_____	_____

Alarm 1 is now inactive

O R ,

Press: 0800

ALARM 1: 08:00		
BKSP	SAVE	CHG
_____	_____	_____

# SYSTEM PROGRAMMING

## 5.4 RESOURCE CATEGORY, cont'd

### ACTION

### RESULT

Press: SAVE

ALARM 1: 08:00		
BACK	NEXT	SHOW
<input type="text"/>	<input type="text"/>	<input type="text"/>

Alarm 1 is now programmed

Press: NEXT

ALARM 2: NONE		
BACK	NEXT	CHG
<input type="text"/>	<input type="text"/>	<input type="text"/>

Press: NEXT

ALARM 8: NONE		
BACK	NEXT	CHG
<input type="text"/>	<input type="text"/>	<input type="text"/>

- NOTES:**
1. When the system alarm is invoked, all idle stations will hear background music from the speaker for one minute if a source of background music is supplied.
  2. The system alarm clock will not be removed upon invoking until it is manually deleted.
  3. Press the **RELEASE** key or go off hook to stop the alarm.
  4. Programming any two system alarm clocks with a time interval of less than two minutes between them is not allowed. If you try to do this, the later one will be ignored.

**DEFAULT:** No system alarms are programmed.

### 5.4.2 All-ENDANT

### ACTION

### RESULT

Press: NEXT

ATTENDANT		
BACK	NEXT	SHOW
<input type="text"/>	<input type="text"/>	<input type="text"/>

Press: SHOW

ZONE 1: 10		
BACK	NEXT	CHG
<input type="text"/>	<input type="text"/>	<input type="text"/>

If station 10 is the attendant for Zone 1

# SYSTEM PROGRAMMING

## 4 RESOURCE CATEGORY, cont'd

ACTION

RESULT

ress: **CHG**

ZONE 1: _		
BKSP	SAVE	CHG
<input type="text"/>	<input type="text"/>	<input type="text"/>

ress: **11**

ZONE 1: 11		
BKSP	SAVE	CHG
<input type="text"/>	<input type="text"/>	<input type="text"/>

ress: **SAVE**

ZONE 1: 11		
BACK	NEXT	CHG
<input type="text"/>	<input type="text"/>	<input type="text"/>

ress: **NEXT**

ZONE 2: NONE		
BACK	NEXT	CHG
<input type="text"/>	<input type="text"/>	<input type="text"/>

ress: **CHG**

ZONE 2: _		
BKSP	SAVE	CHG
<input type="text"/>	<input type="text"/>	<input type="text"/>

ress: **12**

ZONE 2: 12		
BKSP	SAVE	CHG
<input type="text"/>	<input type="text"/>	<input type="text"/>

If station 12 is assigned to Zone 2 (see Set category)

ress: **SAVE**

ZONE 2: 12		
BACK	NEXT	CHG
<input type="text"/>	<input type="text"/>	<input type="text"/>

- NOTES:**
1. Normally, all transferred line calls unanswered within the allowed number of rings will be routed to the attendant within the same zone.
  2. All forced CFW ICM calls will be transferred to the attendant within the same zone.
  3. Incorrectly dialed station numbers or unanswered DISA calls will be transferred to the attendant.
  4. Dialing "0" will route a call to the attendant of the same zone.

**FAULT:** The initial attendant for Zone 1 is station 10 and there is no default attendant for Zone 2.

---

# SYSTEM PROGRAMMING

## 5.4 RESOURCE CATEGORY, *cont'd*

### 5.4.3 SYSTEM SERVICE MODE

<u>ACTION</u>	<u>RESULT</u>										
Press: <b>NEXT</b>	<table border="1"><tr><td colspan="3">SERVICE: TIME</td></tr><tr><td>BACK</td><td>NEXT</td><td>CHG</td></tr><tr><td><input type="text"/></td><td><input type="text"/></td><td><input type="text"/></td></tr></table>	SERVICE: TIME			BACK	NEXT	CHG	<input type="text"/>	<input type="text"/>	<input type="text"/>	TIME/DAY/NIGHT
SERVICE: TIME											
BACK	NEXT	CHG									
<input type="text"/>	<input type="text"/>	<input type="text"/>									
Press: <b>CHG</b>	<table border="1"><tr><td colspan="3">SERVICE: DAY</td></tr><tr><td>BACK</td><td>NEXT</td><td>CHG</td></tr><tr><td><input type="text"/></td><td><input type="text"/></td><td><input type="text"/></td></tr></table>	SERVICE: DAY			BACK	NEXT	CHG	<input type="text"/>	<input type="text"/>	<input type="text"/>	
SERVICE: DAY											
BACK	NEXT	CHG									
<input type="text"/>	<input type="text"/>	<input type="text"/>									
Press: <b>CHG</b>	<table border="1"><tr><td colspan="3">SERVICE: NIGHT</td></tr><tr><td>BACK</td><td>NEXT</td><td>CHG</td></tr><tr><td><input type="text"/></td><td><input type="text"/></td><td><input type="text"/></td></tr></table>	SERVICE: NIGHT			BACK	NEXT	CHG	<input type="text"/>	<input type="text"/>	<input type="text"/>	
SERVICE: NIGHT											
BACK	NEXT	CHG									
<input type="text"/>	<input type="text"/>	<input type="text"/>									

**NOTE:** If the DAY or NIGHT mode is selected, the system will always work in the DAY or NIGHT service mode. Otherwise, the system will work in the TIME service mode and depend on the programmed night start and night end times. These programmed times are used to automatically switch the service mode between day and night.

**DEFAULT:** The system operates in TIME service mode.

### 5.4.4 NIGHT SERVICE

<u>ACTION</u>	<u>RESULT</u>										
Press: <b>NEXT</b>	<table border="1"><tr><td colspan="3">NIGHTSTART: NONE</td></tr><tr><td>BACK</td><td>NEXT</td><td>CHG</td></tr><tr><td><input type="text"/></td><td><input type="text"/></td><td><input type="text"/></td></tr></table>	NIGHTSTART: NONE			BACK	NEXT	CHG	<input type="text"/>	<input type="text"/>	<input type="text"/>	NONE/ 00:00-23:59
NIGHTSTART: NONE											
BACK	NEXT	CHG									
<input type="text"/>	<input type="text"/>	<input type="text"/>									
Press: <b>CHG</b>	<table border="1"><tr><td colspan="3">NIGHTSTART:</td></tr><tr><td>BKSP</td><td>SAVE</td><td>CHG</td></tr><tr><td><input type="text"/></td><td><input type="text"/></td><td><input type="text"/></td></tr></table>	NIGHTSTART:			BKSP	SAVE	CHG	<input type="text"/>	<input type="text"/>	<input type="text"/>	
NIGHTSTART:											
BKSP	SAVE	CHG									
<input type="text"/>	<input type="text"/>	<input type="text"/>									

# SYSTEM PROGRAMMING

## RESOURCE CATEGORY, cont'd

<u>ACTION</u>	<u>RESULT</u>	
: SAVE	NIGHTSTART: NONE BKSP      SAVE      CHG	
OR,		
: 1720	NIGHTSTART: 17:20 BKSP      SAVE      CHG	
: SAVE	NIGHTSTART: 17:20 BACK      NEXT      CHG	
: NEXT	NIGHT END BACK      NEXT      CHG	
: CHG	NIGHT END: _ BKSP      SAVE      CHG	NONE/ 00:00-23:59
0800	NIGHT END: 08:00 BKSP      SAVE      CHG	
SAVE	NIGHT END: 08:00 BACK      NEXT      CHG	

**S: 1.** The programmed night start and night end times will not be checked until the system service mode is assigned the type 'TIME'. Afterwards, system service mode will be changed automatically according to the night start and night end times.

2. Hour and minute programming is in the 24-hour scale.

JLT: The system is in TIME service mode. Night Start and Night End times are not programmed.

# SYSTEM PROGRAMMING

## 5.4 RESOURCE CATEGORY, cont'd

### 5.4.5 USER NAMES PROGRAMMING

ACTION

RESULT

Press: NEXT

USER NAMES		
BACK	NEXT	SHOW
<input type="text"/>	<input type="text"/>	<input type="text"/>

Press: SHOW

SHOW SET: _		
BKSP	SHOW	CHG
<input type="text"/>	<input type="text"/>	<input type="text"/>

Press: 10

SHOW SET: 10		
BKSP	SHOW	CHG
<input type="text"/>	<input type="text"/>	<input type="text"/>

1 0-81, i.e., existing station number

Press: SHOW

SET 10: EMPTY		
BACK	NEXT	CHG
<input type="text"/>	<input type="text"/>	<input type="text"/>

Press: CHG

SET 10: _		
BKSP	SAVE	CHG
<input type="text"/>	<input type="text"/>	<input type="text"/>

Press: **5#666#44#66#**

<del>Maximum</del> 7		
SET 10: JOHN		
BKSP	SAVE	CHG
<input type="text"/>	<input type="text"/>	<input type="text"/>

characters

Press: SAVE

SET 10: JOHN		
BACK	NEXT	CHG
<input type="text"/>	<input type="text"/>	<input type="text"/>

Press: NEXT

SHOW SET: _		
BKSP	SHOW	CHG
<input type="text"/>	<input type="text"/>	<input type="text"/>

# SYSTEM PROGRAMMING

## SOURCE CATEGORY, cont'd

### ACTION

### RESULT

#### SHIFT

USER NAMES		
BACK	NEXT	SHOW

1. Entering alphabetic letter and number digits through the keypad is based on the number of entries the dial key corresponding to the letter sequence printed on the individual keys.

If the number of entries of a dial key exceeds the number of letters printed on the key (three), the display will cycle through these letters repeatedly until one is confirmed.

Each entry must be confirmed by pressing the '#' key.

In addition, the letters 'Q' and 'Z' as well as a space may be entered by pressing the '1' key. One entry of the '1' key represents the letter 'Q', two entries of the '1' key represent the letter 'Z', three entries represent a Space, and four entries represent '1'.

2. In general, the entered letter is regarded as an upper case character. If a lower case character is desired, press the '\*' key when the character you desire appears on the LCD.
3. Under the condition of 'cursor' appearance, the user may press the '#' key to put a 'Space' into the message. The cursor will be moved to the next position.

LT: No name is assigned to any station.

## SYSTEM SPEED DIALING

### ACTION

### RESULT

#### NEXT

SYSTEM	SPD	
BACK	NEXT	SHOW
_____	_____	_____

#### SHOW

SPD	location	(25	99)
SHOW SPD.	SHOW	CHG	
BKSP	_____	_____	_____

# SYSTEM PROGRAMMING

## 5.4 RESOURCE CATEGORY, cont'd

### A C T I O N

### R E S U L T

Press: 25

SHOW SPD: 25		
BKSP	SHOW	CHG
_____	_____	_____

Press: SHOW

EMPTY		
BACK	NEXT	CHG
_____	_____	_____

Press: CHG

<u>BKSP</u>	SAVE	CHG
_____	_____	_____

Press: 775141

775141		
BKSP	SAVE	CHG
_____	_____	_____

Press: SAVE

775141		
BACK	NEXT	CHG
_____	_____	_____

The number '775141' is stored in SPD location '25'.

Press: NEXT

SHOW SPD: <u>  </u>		
BKSP	SHOW	CHG
_____	_____	_____

Press: SHIFT key

SYSTEM SPD		
BACK	NEXT	SHOW
_____	_____	_____

- NOTES: 1. A speed dialing number may contain keypad digits "0,1,...,9,#,\*", a pause "F70", a flash function "F3", and an SPD chaining code "F1nn", where "nn" is an SPD location (25 - 98). "F70" is displayed as a "P" (Pause) and is treated as one digit. "F3" is displayed as an "F" (Flash) and is treated as one digit. "F1nn" is displayed as "@nn" and is treated as three digits.
2. The system will chain dial the contents of SPD location "nn" when it encounters "@nn".
3. Location 99 may be used for External Call Forward (ECF) only.

DEFAULT: All system SPD locations are empty.

# SYSTEM PROGRAMMING

## RESOURCE CATEGORY, cont'd

SYSTEM PASSWORD (DB PSWD)

### ACTION

### RESULT

: NEXT

DB PSWD: 000000		
BACK	NEXT	CHG
<input type="text"/>	<input type="text"/>	<input type="text"/>

If system password is '000000'  
at the present time

: CHG

DB PSWD: _		
BKSP	SAVE	CHG
<input type="text"/>	<input type="text"/>	<input type="text"/>

: 496814

DB PSWD: 496814		
BKSP	SAVE	CHG
<input type="text"/>	<input type="text"/>	<input type="text"/>

Six digits

: SAVE

DB PSWD: 496814		
BACK	NEXT	CHG
<input type="text"/>	<input type="text"/>	<input type="text"/>

⚠: If the system password is forgotten, the user can not enter into the database programming mode again. To overcome this problem, turn the system power off and then turn it on again. The user may then use the password '000000' to enter database programming again within two minutes.

KILT: The initial system password is '000000'.

CALL MONITOR PASSWORD

### ACTION

### RESULT

: NEXT

MONITOR PASSWORD		
BACK	NEXT	SHOW
<input type="text"/>	<input type="text"/>	<input type="text"/>

# SYSTEM PROGRAMMING

## 5.4 RESOURCE CATEGORY, cont'd

<u>ACTION</u>	<u>RESULT</u>			
Press: <b>SHOW</b>	<table border="1"><tr><td>GROUP 1: 4513</td></tr><tr><td>BACK      NEXT      CHG</td></tr><tr><td>_____</td></tr></table>	GROUP 1: 4513	BACK      NEXT      CHG	_____
GROUP 1: 4513				
BACK      NEXT      CHG				
_____				
Press: <b>CHG</b>	<table border="1"><tr><td>GROUP 1: _</td></tr><tr><td>BKSP      <b>SAVE</b>      CHG</td></tr><tr><td>_____</td></tr></table>	GROUP 1: _	BKSP <b>SAVE</b> CHG	_____
GROUP 1: _				
BKSP <b>SAVE</b> CHG				
_____				
Press: 1234	<table border="1"><tr><td>GROUP 1: 1234</td></tr><tr><td>BKSP      SAVE      CHG</td></tr><tr><td>_____</td></tr></table> 4 digits	GROUP 1: 1234	BKSP      SAVE      CHG	_____
GROUP 1: 1234				
BKSP      SAVE      CHG				
_____				
Press: <b>SAVE</b>	<table border="1"><tr><td>GROUP 1: 1234</td></tr><tr><td>BACK      NEXT      CHG</td></tr><tr><td>_____</td></tr></table>	GROUP 1: 1234	BACK      NEXT      CHG	_____
GROUP 1: 1234				
BACK      NEXT      CHG				
_____				
Press: <b>NEXT</b>	<table border="1"><tr><td>GROUP 2: 4513</td></tr><tr><td>BACK      NEXT      CHG</td></tr><tr><td>_____</td></tr></table>	GROUP 2: 4513	BACK      NEXT      CHG	_____
GROUP 2: 4513				
BACK      NEXT      CHG				
_____				
Press: <b>NEXT</b> ,	<table border="1"><tr><td>GROUP 8: 4513</td></tr><tr><td>BACK      NEXT      CHG</td></tr><tr><td>_____</td></tr></table>	GROUP 8: 4513	BACK      NEXT      CHG	_____
GROUP 8: 4513				
BACK      NEXT      CHG				
_____				

- NOTES:**
1. The monitor passwords are associated with the Call Monitoring feature.
  2. Each station group has its own password.
  3. If the monitor password is forgotten, the user may check and see the actual monitor password through database programming.

**DEFAULT:** The default password is '4513' for all groups.

# SYSTEM PROGRAMMING

## RESOURCE CATEGORY, cont'd

### SYSTEM TIME

#### ACTION

#### RESULT

); NEXT

SYSTEM TIME		
BACK	NEXT	SHOW
<input type="text"/>	<input type="text"/>	<input type="text"/>

); SHOW

YEAR: 199_		
BACK	NEXT	CHG
<input type="text"/>	<input type="text"/>	<input type="text"/>

); CHG

YEAR: -		
BKSP	SAVE	CHG
<input type="text"/>	<input type="text"/>	<input type="text"/>

0000 • 9999

); 1995

YEAR: 1995		
BKSP	SAVE	CHG
<input type="text"/>	<input type="text"/>	<input type="text"/>

); SAVE

YEAR: 1995		
BACK	NEXT	CHG
<input type="text"/>	<input type="text"/>	<input type="text"/>

); NEXT

MONTH: JUN		
BACK	NEXT	CHG
<input type="text"/>	<input type="text"/>	<input type="text"/>

); CHG

MONTH: JUL		
BACK	NEXT	CHG
<input type="text"/>	<input type="text"/>	<input type="text"/>

This is a toggle changing process  
(JAN/FEB/.. /DEC)

); NEXT

DAY: 01		
BACK	NEXT	CHG
<input type="text"/>	<input type="text"/>	<input type="text"/>

The updating process is the same  
as that for 'YEAR' (2 digits)

# SYSTEM PROGRAMMING

## 5.4 RESOURCE CATEGORY, conf'd

### ACTION

### RESULT

Press: **NEXT**

WEEKDAY: TUE		
BACK	NEXT	CHG
<input type="text"/>	<input type="text"/>	<input type="text"/>

This is a toggle changing process  
(MON/TUE/.../SUN)

Press: **NEXT**

HOUR: 00		
BACK	NEXT	CHG
<input type="text"/>	<input type="text"/>	<input type="text"/>

The updating process is the same  
as that for 'YEAR'  
2 digits (00 - 23)

Press: **NEXT**

MINUTE: 00		
BACK	NEXT	CHG
<input type="text"/>	<input type="text"/>	<input type="text"/>

The updating process is the same  
as that for 'YEAR'  
2 digits (00 - 59)

- NOTES:**
1. There are six **types** of time parameters available for programming. They include Year, Month, Day, Weekday, Hour, and Minute.
  2. **When** 'MINUTE' is updated, the seconds are automatically reset and begin counting from zero.
  3. Hour and minute programming are in **24-hour** mode.

**DEFAULT:** The initial system time is set to 12:00 am, TUE, JUN 1, 199\_.

### 5.4.10 SET COPY

### ACTION

### RESULT

Press: **NEXT**

SET COPY		
BACK	NEXT	SHOW
<input type="text"/>	<input type="text"/>	<input type="text"/>

Press: **SHOW**

COPY FROM: _		
BKSP	SAVE	CHG
<input type="text"/>	<input type="text"/>	<input type="text"/>

10-81 ,i.e., existing station number

# SYSTEM PROGRAMMING

## RESOURCE CATEGORY, conf'd

### ACTION

### RESULT

s: 10

COPY FROM: 10		
BKSP	SAVE	CHG
<input type="text"/>	<input type="text"/>	<input type="text"/>

s: SAVE

COPY TO: _		
<del>BKSP</del>	<del>SAVE</del>	<del>CHG</del>
<input type="text"/>	<input type="text"/>	<input type="text"/>

s: 12

COPY TO: 12		
BKSP	NEXT	CHG
<input type="text"/>	<input type="text"/>	<input type="text"/>

1 O-81, i.e., existing station number

s: SAVE

SET COPY		
BACK	NEXT	SHOW
<input type="text"/>	<input type="text"/>	<input type="text"/>

'ES: 1. The user may first program one station set with the required feature programming and then copy this information to all other stations needing the same programming status.

2. The copy range of "Set Copy" includes the following feature parameters:

- A. Day COS
- B. Night COS
- C. Line assignment
- D. Ring assignment
- E. Set group number
- F. Zone number
- G. LCR enable
- H. ICM type (Ring/ Voice Call)
- I. Feature key map

3. When 'SET COPY' is activated, the copy destination automatically resets to avoid any possible inconsistencies.

**AULT:** None

# SYSTEM PROGRAMMING

## 5.4 RESOURCE CATEGORY, cont'd

### 5.4.11 LINE COPY

#### ACTION

#### RESULT

Press: **NEXT**

LINE COPY		
BACK	NEXT	SHOW
<input type="text"/>	<input type="text"/>	<input type="text"/>

Press: **SHOW**

COPY FROM:		
BKSP	SAVE	CHG
<input type="text"/>	<input type="text"/>	<input type="text"/>

existing line number (01-06)

Press: **01**

COPY FROM: 01		
BKSP	SAVE	CHG
<input type="text"/>	<input type="text"/>	<input type="text"/>

Press: **SAVE**

COPY TO:		
BKSP	SAVE	CHG
<input type="text"/>	<input type="text"/>	<input type="text"/>

existing line number (01-06)

Press: **02**

COPY TO: 02		
BKSP	SAVE	CHG
<input type="text"/>	<input type="text"/>	<input type="text"/>

Press: **SAVE**

LINE COPY		
BACK	NEXT	SHOW
<input type="text"/>	<input type="text"/>	<input type="text"/>

**NOTES:** 1. The user may first program one line with the required feature programming and then copy this information to all other lines needing the same programming status.

2. The copy range of 'LINE COPY' includes the following parameters:

- A. Day Class
- B. Night Class
- C. Dialing type
- D. Line type

- E. Loud Bell (enable/disable)
- F. Line Pool number
- G. Privacy
- H. Hunt Group Answer

**DEFAULT:** None

# SYSTEM PROGRAMMING

## 4 RESOURCE CATEGORY, cont'd

### 4.12 USER PASSWORD

#### ACTION

#### RESULT

PASS: NEXT

USER PASSWORD		
BACK	NEXT	SHOW
<input type="text"/>	<input type="text"/>	<input type="text"/>

PASS: SHOW

SHOW SET: _		
BKSP	SHOW	CHG
<input type="text"/>	<input type="text"/>	<input type="text"/>

10-81 ,i.e., existing station number

PASS: 10

SHOW SET: 10		
BKSP	SHOW	CHG
<input type="text"/>	<input type="text"/>	<input type="text"/>

PASS: SHOW

SET PSWD: 0000		
BACK	NEXT	
<input type="text"/>	<input type="text"/>	<input type="text"/>

PASS: NEXT

SHOW SET:		
BKSP	SHOW	CHG
<input type="text"/>	<input type="text"/>	<input type="text"/>

PASS: SHIFT

USER PASSWORD		
BACK	NEXT	SHOW
<input type="text"/>	<input type="text"/>	<input type="text"/>

**NOTE:** If the user forgets the **station password**, the actual station password can be checked **through data** base programming.

**FAULT:** Each station's password is '0000'.

# SYSTEM PROGRAMMING

## 5.4 RESOURCE CATEGORY, cont'd

### 5.4.13 MESSAGES

#### ACTION

#### RESULT

Press: **NEXT**

MESSAGES		
BACK	NEXT	SHOW
<input type="text"/>	<input type="text"/>	<input type="text"/>

Press: **SHOW**

SPECIAL MESSAGE		
BACK	NEXT	SHOW
<input type="text"/>	<input type="text"/>	<input type="text"/>

Press: **SHOW**

CALL BACK XX		
BACK	NEXT	
<input type="text"/>	<input type="text"/>	<input type="text"/>

'XX' is the station number that is leaving the message.

Press: **NEXT**

URGENT XX		
BACK	NEXT	
<input type="text"/>	<input type="text"/>	<input type="text"/>

'XX' is the station number that is leaving the message.

Press: **NEXT**

CALL OPERATOR		
BACK	NEXT	CHG.
<input type="text"/>	<input type="text"/>	<input type="text"/>

The updating process is the same as that for User Names (maximum 16 characters)

Press: **NEXT**

CALL HOME		
BACK	NEXT	CHG
<input type="text"/>	<input type="text"/>	<input type="text"/>

Press: **NEXT**

VISITOR WAITING		
BACK	NEXT	CHG
<input type="text"/>	<input type="text"/>	<input type="text"/>

Press: **NEXT**

ADVISORY MESSAGE		
BACK	NEXT	SHOW,
<input type="text"/>	<input type="text"/>	<input type="text"/>

# SYSTEM PROGRAMMING

## 4 RESOURCE CATEGORY, cont'd

### ACTION

### RESULT

ess: SHOW

AT LUNCH		
BACK	NEXT	CHG
<input type="text"/>	<input type="text"/>	<input type="text"/>

The updating process is the same as that for User Names (maximum 16 characters)

ess: NEXT

BE BACK SOON		
BACK	NEXT	CHG
<input type="text"/>	<input type="text"/>	<input type="text"/>

ess: NEXT

IN A MEETING		
BACK	NEXT	CHG
<input type="text"/>	<input type="text"/>	<input type="text"/>

ess: NEXT

OUT OF OFFICE		
BACK	NEXT	CHG
<input type="text"/>	<input type="text"/>	<input type="text"/>

ess: NEXT

ON VACATION		
BACK	NEXT	CHG
<input type="text"/>	<input type="text"/>	<input type="text"/>

ess: CHG

BKSP		
SAVE	CHG	
<input type="text"/>	<input type="text"/>	<input type="text"/>

ess: 4#666#66#33##  
333#444#777#44#  
444#66#4#

GONE FISHING		
BKSP	SAVE	CHG
<input type="text"/>	<input type="text"/>	<input type="text"/>

ess: SAVE

GONE FISHING		
BACK	NEXT	CHG
<input type="text"/>	<input type="text"/>	<input type="text"/>

The message 'GONE FISHING' is stored as the fifth system advisory message, replacing 'ON VACATION'.

# SYSTEM PROGRAMMING

## 5.4 RESOURCE CATEGORY, *cont'd*

- NOTES: 1. Included in the special messages are 2 fixed system messages, 3 system programmable messages, and two other private programmable messages.
2. Each preprogrammed message can contain a maximum of 16 characters.
3. The initial system preset special messages are:  
'CALL BACK XX'  
'URGENT XX'  
'CALL OPERATOR'  
'CALL HOME'  
'VISITOR WAITING'
4. The initial system preset advisory messages are:  
'AT LUNCH'  
'BE BACK SOON'  
'IN A MEETING'  
'OUT OF OFFICE'  
'ON VACATION'
5. The initial private special and advisory messages are empty.
6. Programming messages uses the same exact method as User Name Programming. Refer to the note containing programming information in the 'User Name Programming' section.

### 5.4.14 HOUR MODE SELECTION

<u>ACTION</u>	<u>RESULT</u>										
Press: NEXT	<table border="1"><tr><td>HOUR MODE: 12</td><td></td><td></td></tr><tr><td>BACK</td><td>NEXT</td><td>CHG</td></tr><tr><td>_____</td><td>_____</td><td>_____</td></tr></table>	HOUR MODE: 12			BACK	NEXT	CHG	_____	_____	_____	12/24
HOUR MODE: 12											
BACK	NEXT	CHG									
_____	_____	_____									
Press: CHG	<table border="1"><tr><td>HOUR MODE: 24</td><td></td><td></td></tr><tr><td>BACK</td><td>NEXT</td><td>CHG</td></tr><tr><td>_____</td><td>_____</td><td>_____</td></tr></table>	HOUR MODE: 24			BACK	NEXT	CHG	_____	_____	_____	12/24
HOUR MODE: 24											
BACK	NEXT	CHG									
_____	_____	_____									

The following is the display format for the two possible hour modes. LCD will display the following:

If the 24 hour mode is selected, the

JAN 30 WED	13:30
SET 10	
_____	_____

Indicating the time is 1:30 pm

SEP 9 TUE	10:25
SET 10	
_____	_____

Indicating the time is 10:25 am

# SYSTEM PROGRAMMING

## 4 RESOURCE CATEGORY, cont'd

For the 12 hour mode, the LCD will display the following:

JAN 30 WED 1:30 PM  
SET 10

SEP 9 TUE 10:25 AM  
SET 10

indicating the time is 10:25 am

**NOTE:** For the 12 hour mode, the user can see the actual time in PM or AM from the LCD display.

**FAULT:** System time will be displayed in the 12 hour mode.

### 1.15 KSU REVISION

#### ACTION

#### RESULT

ess: NEXT

KSU REVISION  
BACK NEXT SHOW

ess: SHOW

System W0.Fxx software version  
BACK NEXT

**NOTE:** With this feature, the administrator can easily keep track of the status of the system software, which is helpful for problem analysis and solving.

**FAULT:** None

# SYSTEM PROGRAMMING

## 5.4 RESOURCE CATEGORY, conf'd

### 5.4.16 DEFAULT SETTING (SYSTEM)

#### ACTION

#### RESULT

Press: **NEXT**

DEFAULT SETTING		
BACK	NEXT	SHOW
<input type="text"/>	<input type="text"/>	<input type="text"/>

Press: **SHOW**

PASSWORD: _		
BKSP	<b>SHOW</b>	CHG
<input type="text"/>	<input type="text"/>	<input type="text"/>

Press: 000000

PASSWORD: 000000		
BKSP	SHOW	CHG
<input type="text"/>	<input type="text"/>	<input type="text"/>

System password

Press: **SHOW**

ARE YOU SURE?		
NO		YES
<input type="text"/>	<input type="text"/>	<input type="text"/>

#### **ACTIVATION:**

Press: **YES**

DEFAULT SETTING		
<hr/> <hr/>		

System reset is activated. Display appears on all Professional **keysets**

#### **EXIT:**

Press: **NO**

VM HUNT GROUP: N		
BACK	NEXT	CHG
<input type="text"/>	<input type="text"/>	<input type="text"/>

**N, 1 - 8**

Note: 'N' - no Hunt Group is assigned as VM Hunt Group

**NOTE:** When this function is activated, the system will be restarted 'cold' with the default programming status. All operations in progress will be terminated. Please use caution when invoking this **function**.

**DEFAULT:** None

# SYSTEM PROGRAMMING

## RESOURCE CATEGORY, cont'd

### VOICE MAIL (VM) HUNT GROUP ASSIGNMENT

ACTION

RESULT

CHG

VM HUNT GROUP: 1		
BACK	NEXT	CHG
<input type="text"/>	<input type="text"/>	<input type="text"/>

ULT: No Hunt Group is assigned as a Voice Mail Hunt Group.

### HUNT GROUP PROGRAMMING

ACTION

RESULT

NEXT

HUNT GROUP		
BACK	NEXT	SHOW
<input type="text"/>	<input type="text"/>	<input type="text"/>

SHOW

HUNT GROUP: _		
BKSP	SHOW	CHG
<input type="text"/>	<input type="text"/>	<input type="text"/>

1

HUNT GROUP: 1		
BKSP	SHOW	CHG
<input type="text"/>	<input type="text"/>	<input type="text"/>

1-8

SHOW

HUNT FROM: FIRST		
BACK	NEXT	CHG
<input type="text"/>	<input type="text"/>	<input type="text"/>

FIRST/NEXT

NEXT

GROUP MEMBER		
BACK	NEXT	SHOW
<input type="text"/>	<input type="text"/>	<input type="text"/>

# SYSTEM PROGRAMMING

## 5.4 RESOURCE CATEGORY, cont'd

<u>ACTION</u>	<u>RESULT</u>										
Press: SHOW	<table border="1"><tr><td colspan="3">MEMBER 01: NONE</td></tr><tr><td>BACK</td><td>NEXT</td><td>CHG</td></tr><tr><td colspan="3">_____</td></tr></table>	MEMBER 01: NONE			BACK	NEXT	CHG	_____			NONE/10-81, i.e., existing set number
MEMBER 01: NONE											
BACK	NEXT	CHG									
_____											
Press: NEXT	<table border="1"><tr><td colspan="3">MEMBER 24: NONE</td></tr><tr><td>BACK</td><td>NEXT</td><td>CHG</td></tr><tr><td>_____</td><td>_____</td><td>_____</td></tr></table>	MEMBER 24: NONE			BACK	NEXT	CHG	_____	_____	_____	NONE/10-81, i.e., existing set number
MEMBER 24: NONE											
BACK	NEXT	CHG									
_____	_____	_____									
Press: CHG	<table border="1"><tr><td colspan="3">MEMBER 24: _</td></tr><tr><td>BKSP</td><td>SAVE</td><td>CHG</td></tr><tr><td>_____</td><td>_____</td><td>_____</td></tr></table>	MEMBER 24: _			BKSP	SAVE	CHG	_____	_____	_____	10-81, i.e., existing set number
MEMBER 24: _											
BKSP	SAVE	CHG									
_____	_____	_____									
Press: 12	<table border="1"><tr><td colspan="3">MEMBER 24: 12</td></tr><tr><td>BKSP</td><td>SAVE</td><td>CHG</td></tr><tr><td>_____</td><td>_____</td><td>_____</td></tr></table>	MEMBER 24: 12			BKSP	SAVE	CHG	_____	_____	_____	
MEMBER 24: 12											
BKSP	SAVE	CHG									
_____	_____	_____									
Press: SAVE	<table border="1"><tr><td colspan="3">MEMBER 24: 12</td></tr><tr><td>BACK</td><td>NEXT</td><td>CHG</td></tr><tr><td>_____</td><td>_____</td><td>_____</td></tr></table>	MEMBER 24: 12			BACK	NEXT	CHG	_____	_____	_____	
MEMBER 24: 12											
BACK	NEXT	CHG									
_____	_____	_____									
Press: NEXT	<table border="1"><tr><td colspan="3">HUNT GROUP:</td></tr><tr><td>BKSP</td><td>SHOW</td><td>CHG</td></tr><tr><td>_____</td><td>_____</td><td>_____</td></tr></table>	HUNT GROUP:			BKSP	SHOW	CHG	_____	_____	_____	
HUNT GROUP:											
BKSP	SHOW	CHG									
_____	_____	_____									
Press: SHIFT key	<table border="1"><tr><td colspan="3">HUNT GROUP</td></tr><tr><td>BACK</td><td>NEXT</td><td>SHOW</td></tr><tr><td>_____</td><td>_____</td><td>_____</td></tr></table>	HUNT GROUP			BACK	NEXT	SHOW	_____	_____	_____	
HUNT GROUP											
BACK	NEXT	SHOW									
_____	_____	_____									

- NOTES:
1. The pilot numbers of the Hunt Group range from 82 to 89.
  2. If the 'HUNT FROM' is 'FIRST', then the system will always search for an idle number from the first member to the last member, with a maximum of 24 members. If 'NEXT' is programmed, then the system will search for the idle number starting with the last member selected.
  3. Each station can belong to more than one Hunt Group.

DEFAULT: 'HUNT FROM' is 'FIRST' for all Hunt Groups. No member belongs to all Hunt Groups.

# SYSTEM PROGRAMMING

## 5 RESTRICTION CATEGORY

ACTION

RESULT

Press: NEXT

5. RESTRICTION		
BACK	NEXT	SHOW
<input type="text"/>	<input type="text"/>	<input type="text"/>

### 5.1 TOLL RESTRICTION

ACTION

RESULT

Press: SHOW

TOLL RESTRICTION		
BACK	NEXT	SHOW
<input type="text"/>	<input type="text"/>	<input type="text"/>

Press: SHOW

RESTRICT TABLE		
BACK	NEXT	SHOW
<input type="text"/>	<input type="text"/>	<input type="text"/>

Press: SHOW

TABLE ENTRY: _		
BKSP	SHOW	CHG
<input type="text"/>	<input type="text"/>	<input type="text"/>

There are 50 entries for the Restriction Table

Press: 01

TABLE ENTRY: 01		
BKSP	SHOW	CHG
<input type="text"/>	<input type="text"/>	<input type="text"/>

Two digits must be entered (01-50)

Press: SHOW

RESTRICT NUMBER		
BACK	NEXT	SHOW
<input type="text"/>	<input type="text"/>	<input type="text"/>

Press: SHOW

1900		
BACK	NEXT	CHG
<input type="text"/>	<input type="text"/>	<input type="text"/>

# SYSTEM PROGRAMMING

## 5.5 RESTRICTION CATEGORY, cont'd

ACTION

RESULT

Press: CHG

<b>BKSP</b>	SAVE	CHG
<input type="text"/>	<input type="text"/>	<input type="text"/>

Maximum 8 digits

Press: 002

002		
<b>BKSP</b>	SAVE	CHG
<input type="text"/>	<input type="text"/>	<input type="text"/>

Press: **SAVE**

002		
<b>BACK</b>	NEXT	CHG
<input type="text"/>	<input type="text"/>	<input type="text"/>

Press: **NEXT**

STATION COS		
<b>BACK</b>	NEXT	SHOW
<input type="text"/>	<input type="text"/>	<input type="text"/>

Press: **SHOW**

DAY COS		
<b>BACK</b>	NEXT	SHOW
<input type="text"/>	<input type="text"/>	<input type="text"/>

Press: **SHOW**

<b>COS 0: N</b>		
<b>BACK</b>	NEXT	CHG
<input type="text"/>	<input type="text"/>	<input type="text"/>

Y/N

Press: CHG

<b>cos 0: Y</b>		
<b>BACK</b>	NEXT	CHG
<input type="text"/>	<input type="text"/>	<input type="text"/>

Press: **NEXT**

<b>cos 1: Y</b>		
<b>BACK</b>	NEXT	CHG
<input type="text"/>	<input type="text"/>	<input type="text"/>

# SYSTEM PROGRAMMING

## RESTRICTION CATEGORY, cont'd

ACTION

RESULT

s: NEXT

COS 7: N		
BACK	NEXT	CHG
<input type="text"/>	<input type="text"/>	<input type="text"/>

s: NEXT

NIGHT COS		
BACK	NEXT	SHOW
<input type="text"/>	<input type="text"/>	<input type="text"/>

s: SHOW

COS 0: N		
BACK	NEXT	CHG
<input type="text"/>	<input type="text"/>	<input type="text"/>

YIN

s: CHG

cos 0: Y		
BACK	NEXT	CHG
<input type="text"/>	<input type="text"/>	<input type="text"/>

s: NEXT

COS 1: Y		
BACK	NEXT	CHG
<input type="text"/>	<input type="text"/>	<input type="text"/>

s: NEXT

COS 7: N		
BACK	NEXT	CHG
<input type="text"/>	<input type="text"/>	<input type="text"/>

s: NEXT

LINE COS		
BACK	NEXT	SHOW
<input type="text"/>	<input type="text"/>	<input type="text"/>

s: SHOW

DAY COS		
BACK	NEXT	SHOW
<input type="text"/>	<input type="text"/>	<input type="text"/>

# SYSTEM PROGRAMMING

## 5.5 RESTRICTION CATEGORY, cont'd

<u>ACTION</u>	<u>RESULT</u>										
Press: <b>SHOW</b>	<table border="1"><tr><td colspan="3">COS 0: N</td></tr><tr><td>BACK</td><td>NEXT</td><td>CHG</td></tr><tr><td><input type="text"/></td><td><input type="text"/></td><td><input type="text"/></td></tr></table>	COS 0: N			BACK	NEXT	CHG	<input type="text"/>	<input type="text"/>	<input type="text"/>	Y/N
COS 0: N											
BACK	NEXT	CHG									
<input type="text"/>	<input type="text"/>	<input type="text"/>									
Press: <b>CHG</b>	<table border="1"><tr><td colspan="3">cos 0: Y</td></tr><tr><td>BACK</td><td>NEXT</td><td>CHG</td></tr><tr><td><input type="text"/></td><td><input type="text"/></td><td><input type="text"/></td></tr></table>	cos 0: Y			BACK	NEXT	CHG	<input type="text"/>	<input type="text"/>	<input type="text"/>	
cos 0: Y											
BACK	NEXT	CHG									
<input type="text"/>	<input type="text"/>	<input type="text"/>									
Press: <b>NEXT</b>	<table border="1"><tr><td colspan="3">COS 1: Y</td></tr><tr><td>BACK</td><td>NEXT</td><td>CHG</td></tr><tr><td><input type="text"/></td><td><input type="text"/></td><td><input type="text"/></td></tr></table>	COS 1: Y			BACK	NEXT	CHG	<input type="text"/>	<input type="text"/>	<input type="text"/>	
COS 1: Y											
BACK	NEXT	CHG									
<input type="text"/>	<input type="text"/>	<input type="text"/>									
Press: <b>NEXT</b>	<table border="1"><tr><td colspan="3">COS 7: N</td></tr><tr><td>BACK</td><td>NEXT</td><td>CHG</td></tr><tr><td><input type="text"/></td><td><input type="text"/></td><td><input type="text"/></td></tr></table>	COS 7: N			BACK	NEXT	CHG	<input type="text"/>	<input type="text"/>	<input type="text"/>	
COS 7: N											
BACK	NEXT	CHG									
<input type="text"/>	<input type="text"/>	<input type="text"/>									
Press: <b>NEXT</b>	<table border="1"><tr><td colspan="3">NIGHT COS</td></tr><tr><td>BACK</td><td>NEXT</td><td>SHOW</td></tr><tr><td><input type="text"/></td><td><input type="text"/></td><td><input type="text"/></td></tr></table>	NIGHT COS			BACK	NEXT	SHOW	<input type="text"/>	<input type="text"/>	<input type="text"/>	
NIGHT COS											
BACK	NEXT	SHOW									
<input type="text"/>	<input type="text"/>	<input type="text"/>									
Press: <b>SHOW</b>	<table border="1"><tr><td colspan="3">COS 0: N</td></tr><tr><td>BACK</td><td>NEXT</td><td>CHG</td></tr><tr><td><input type="text"/></td><td><input type="text"/></td><td><input type="text"/></td></tr></table>	COS 0: N			BACK	NEXT	CHG	<input type="text"/>	<input type="text"/>	<input type="text"/>	YIN
COS 0: N											
BACK	NEXT	CHG									
<input type="text"/>	<input type="text"/>	<input type="text"/>									
Press: <b>CHG</b>	<table border="1"><tr><td colspan="3">cos 0: Y</td></tr><tr><td>BACK</td><td>NEXT</td><td>CHG</td></tr><tr><td><input type="text"/></td><td><input type="text"/></td><td><input type="text"/></td></tr></table>	cos 0: Y			BACK	NEXT	CHG	<input type="text"/>	<input type="text"/>	<input type="text"/>	
cos 0: Y											
BACK	NEXT	CHG									
<input type="text"/>	<input type="text"/>	<input type="text"/>									
Press: <b>NEXT</b>	<table border="1"><tr><td colspan="3">COS 1: Y</td></tr><tr><td>BACK</td><td>NEXT</td><td>CHG</td></tr><tr><td><input type="text"/></td><td><input type="text"/></td><td><input type="text"/></td></tr></table>	COS 1: Y			BACK	NEXT	CHG	<input type="text"/>	<input type="text"/>	<input type="text"/>	
COS 1: Y											
BACK	NEXT	CHG									
<input type="text"/>	<input type="text"/>	<input type="text"/>									

# SYSTEM PROGRAMMING

## RESTRICTION CATEGORY, cont'd

ACTION

RESULT

s: NEXT

COS 7: N		
BACK	NEXT	CHG
<input type="text"/>	<input type="text"/>	<input type="text"/>

s: NEXT

TABLE ENTRY: _		
BKSP	SHOW	CHG
<input type="text"/>	<input type="text"/>	<input type="text"/>

s: SHIFT key

RESTRICT TABLE		
BACK	NEXT	SHOW
<input type="text"/>	<input type="text"/>	<input type="text"/>

s: NEXT

EXCEPTION TABLE		
BACK	NEXT.	SHOW
<input type="text"/>	<input type="text"/>	<input type="text"/>

s: SHOW

TABLE ENTRY: _		
BKSP	SHOW	CHG
<input type="text"/>	<input type="text"/>	<input type="text"/>

There are 20 entries for the Exception Table

s: 01

TABLE ENTRY: 01		
BKSP	SHOW	CHG
<input type="text"/>	<input type="text"/>	<input type="text"/>

01-20

s: SHOW

EXCEPTION NUMBER		
BACK	NEXT	SHOW
<input type="text"/>	<input type="text"/>	<input type="text"/>

s: SHOW

EMPTY		
BACK	NEXT	CHG
<input type="text"/>	<input type="text"/>	<input type="text"/>

# SYSTEM PROGRAMMING

## 5.5 RESTRICTION CATEGORY, cont'd

<u>ACTION</u>	<u>RESULT</u>							
Press: <b>CHG</b>	<table border="1"><tr><td><u>  </u> <u>  </u> <u>  </u></td><td><u>  </u> <u>  </u> <u>  </u></td><td><u>  </u> <u>  </u> <u>  </u></td></tr><tr><td><b>BKSP</b></td><td><b>SAVE</b></td><td><b>CHG</b></td></tr></table>	<u>  </u> <u>  </u> <u>  </u>	<u>  </u> <u>  </u> <u>  </u>	<u>  </u> <u>  </u> <u>  </u>	<b>BKSP</b>	<b>SAVE</b>	<b>CHG</b>	Maximum of 14 digits
<u>  </u> <u>  </u> <u>  </u>	<u>  </u> <u>  </u> <u>  </u>	<u>  </u> <u>  </u> <u>  </u>						
<b>BKSP</b>	<b>SAVE</b>	<b>CHG</b>						
Press: 1607	<table border="1"><tr><td><u>  </u> <u>  </u> <u>  </u></td><td><u>  </u> <u>  </u> <u>  </u></td><td><u>  </u> <u>  </u> <u>  </u></td></tr><tr><td>1607</td><td><b>BKSP</b></td><td><b>SAVE</b> <b>CHG</b></td></tr></table>	<u>  </u> <u>  </u> <u>  </u>	<u>  </u> <u>  </u> <u>  </u>	<u>  </u> <u>  </u> <u>  </u>	1607	<b>BKSP</b>	<b>SAVE</b> <b>CHG</b>	
<u>  </u> <u>  </u> <u>  </u>	<u>  </u> <u>  </u> <u>  </u>	<u>  </u> <u>  </u> <u>  </u>						
1607	<b>BKSP</b>	<b>SAVE</b> <b>CHG</b>						
Press: <b>SAVE</b>	<table border="1"><tr><td><u>  </u> <u>  </u> <u>  </u></td><td><u>  </u> <u>  </u> <u>  </u></td><td><u>  </u> <u>  </u> <u>  </u></td></tr><tr><td>1607</td><td><b>BACK</b></td><td><b>NEXT</b> <b>CHG</b></td></tr></table>	<u>  </u> <u>  </u> <u>  </u>	<u>  </u> <u>  </u> <u>  </u>	<u>  </u> <u>  </u> <u>  </u>	1607	<b>BACK</b>	<b>NEXT</b> <b>CHG</b>	
<u>  </u> <u>  </u> <u>  </u>	<u>  </u> <u>  </u> <u>  </u>	<u>  </u> <u>  </u> <u>  </u>						
1607	<b>BACK</b>	<b>NEXT</b> <b>CHG</b>						
Press: <b>NEXT</b>	<table border="1"><tr><td><u>  </u> <u>  </u> <u>  </u></td><td><u>  </u> <u>  </u> <u>  </u></td><td><u>  </u> <u>  </u> <u>  </u></td></tr><tr><td>STATION</td><td><b>BACK</b></td><td><b>COS</b> <b>NEXT</b> <b>SHOW</b></td></tr></table>	<u>  </u> <u>  </u> <u>  </u>	<u>  </u> <u>  </u> <u>  </u>	<u>  </u> <u>  </u> <u>  </u>	STATION	<b>BACK</b>	<b>COS</b> <b>NEXT</b> <b>SHOW</b>	
<u>  </u> <u>  </u> <u>  </u>	<u>  </u> <u>  </u> <u>  </u>	<u>  </u> <u>  </u> <u>  </u>						
STATION	<b>BACK</b>	<b>COS</b> <b>NEXT</b> <b>SHOW</b>						
Press: <b>SHOW</b>	<table border="1"><tr><td><u>  </u> <u>  </u> <u>  </u></td><td><u>  </u> <u>  </u> <u>  </u></td><td><u>  </u> <u>  </u> <u>  </u></td></tr><tr><td>DAY</td><td><b>BACK</b></td><td><b>COS</b> <b>NEXT</b> <b>SHOW</b></td></tr></table>	<u>  </u> <u>  </u> <u>  </u>	<u>  </u> <u>  </u> <u>  </u>	<u>  </u> <u>  </u> <u>  </u>	DAY	<b>BACK</b>	<b>COS</b> <b>NEXT</b> <b>SHOW</b>	
<u>  </u> <u>  </u> <u>  </u>	<u>  </u> <u>  </u> <u>  </u>	<u>  </u> <u>  </u> <u>  </u>						
DAY	<b>BACK</b>	<b>COS</b> <b>NEXT</b> <b>SHOW</b>						
Press: <b>SHOW</b>	<table border="1"><tr><td><u>  </u> <u>  </u> <u>  </u></td><td><u>  </u> <u>  </u> <u>  </u></td><td><u>  </u> <u>  </u> <u>  </u></td></tr><tr><td><b>COSO: N</b></td><td><b>BACK</b></td><td><b>NEXT</b> <b>CHG</b></td></tr></table>	<u>  </u> <u>  </u> <u>  </u>	<u>  </u> <u>  </u> <u>  </u>	<u>  </u> <u>  </u> <u>  </u>	<b>COSO: N</b>	<b>BACK</b>	<b>NEXT</b> <b>CHG</b>	Y/N
<u>  </u> <u>  </u> <u>  </u>	<u>  </u> <u>  </u> <u>  </u>	<u>  </u> <u>  </u> <u>  </u>						
<b>COSO: N</b>	<b>BACK</b>	<b>NEXT</b> <b>CHG</b>						
Press: <b>CHG</b>	<table border="1"><tr><td><u>  </u> <u>  </u> <u>  </u></td><td><u>  </u> <u>  </u> <u>  </u></td><td><u>  </u> <u>  </u> <u>  </u></td></tr><tr><td>cos 0: Y</td><td><b>BACK</b></td><td><b>NEXT</b> <b>CHG</b></td></tr></table>	<u>  </u> <u>  </u> <u>  </u>	<u>  </u> <u>  </u> <u>  </u>	<u>  </u> <u>  </u> <u>  </u>	cos 0: Y	<b>BACK</b>	<b>NEXT</b> <b>CHG</b>	
<u>  </u> <u>  </u> <u>  </u>	<u>  </u> <u>  </u> <u>  </u>	<u>  </u> <u>  </u> <u>  </u>						
cos 0: Y	<b>BACK</b>	<b>NEXT</b> <b>CHG</b>						
Press: <b>NEXT</b>	<table border="1"><tr><td><u>  </u> <u>  </u> <u>  </u></td><td><u>  </u> <u>  </u> <u>  </u></td><td><u>  </u> <u>  </u> <u>  </u></td></tr><tr><td><b>COSI: N</b></td><td><b>BACK</b></td><td><b>NEXT</b> <b>CHG</b></td></tr></table>	<u>  </u> <u>  </u> <u>  </u>	<u>  </u> <u>  </u> <u>  </u>	<u>  </u> <u>  </u> <u>  </u>	<b>COSI: N</b>	<b>BACK</b>	<b>NEXT</b> <b>CHG</b>	
<u>  </u> <u>  </u> <u>  </u>	<u>  </u> <u>  </u> <u>  </u>	<u>  </u> <u>  </u> <u>  </u>						
<b>COSI: N</b>	<b>BACK</b>	<b>NEXT</b> <b>CHG</b>						

# SYSTEM PROGRAMMING

## 5 RESTRICTION CATEGORY, cont'd

ACTION

RESULT

SS: NEXT

COS 7: N		
BACK	NEXT	CHG
<input type="text"/>	<input type="text"/>	<input type="text"/>

SS: NEXT

NIGHT COS		
<del>BACK</del>	<del>NEXT</del>	<del>CHG</del>
<input type="text"/>	<input type="text"/>	<input type="text"/>

SS: SHOW

COS 0: N		
BACK	NEXT	CHG
<input type="text"/>	<input type="text"/>	<input type="text"/>

Y/N

SS: CHG

cos 0: Y		
BACK	NEXT	CHG
<input type="text"/>	<input type="text"/>	<input type="text"/>

SS: NEXT

COSI: N		
BACK	NEXT	CHG
<input type="text"/>	<input type="text"/>	<input type="text"/>

SS: NEXT

COS 7: N		
BACK	NEXT	CHG
<input type="text"/>	<input type="text"/>	<input type="text"/>

SS: NEXT

LINE COS		
BACK	NEXT	SHOW
<input type="text"/>	<input type="text"/>	<input type="text"/>

SS: SHOW

DAY COS		
BACK	NEXT	SHOW
<input type="text"/>	<input type="text"/>	<input type="text"/>

# SYSTEM PROGRAMMING

## 5.5 RESTRICTION CATEGORY, cont'd

ACTION

RESULT

Press: **SHOW**

<b>COS 0: N</b>		
BACK	NEXT	CHG
<input type="text"/>	<input type="text"/>	<input type="text"/>

Y/N

Press: **CHG**

<b>cos 0: Y</b>		
BACK	NEXT	CHG
<input type="text"/>	<input type="text"/>	<input type="text"/>

Press: **NEXT**

<b>COS 1: N</b>		
BACK	NEXT	CHG
<input type="text"/>	<input type="text"/>	<input type="text"/>

Press: **NEXT**

<b>COS 7: N</b>		
BACK	NEXT	CHG
<input type="text"/>	<input type="text"/>	<input type="text"/>

Press: **NEXT**

<b>NIGHT COS</b>		
BACK	NEXT	SHOW
<input type="text"/>	<input type="text"/>	<input type="text"/>

Press: **SHOW**

<b>COS 0: N</b>		
BACK	NEXT	CHG
<input type="text"/>	<input type="text"/>	<input type="text"/>

Y/N

Press: **CHG**

<b>cos 0: Y</b>		
BACK	NEXT	CHG
<input type="text"/>	<input type="text"/>	<input type="text"/>

Press: **NEXT**

<b>COS 1: N</b>		
BACK	NEXT	CHG
<input type="text"/>	<input type="text"/>	<input type="text"/>

# SYSTEM PROGRAMMING

## RESTRICTION CATEGORY, cont'd

### ACTION

### RESULT

SS: NEXT

COS 7: N		
<del>BACK</del>	<del>NEXT</del>	<del>CHG</del>
<input type="text"/>	<input type="text"/>	<input type="text"/>

§S: NEXT

TABLE ENTRY: _		
BKSP	SHOW	CHG
<input type="text"/>	<input type="text"/>	<input type="text"/>

s: SHIFT key

EXCEPTION TABLE		
BACK	NEXT	SHOW
<input type="text"/>	<input type="text"/>	<input type="text"/>

ES: 1. There are 50 total entries in the Restriction Table and 20 total entries in the **Exception Table**.

2. Each entry into both the Restriction Table and the Exception Table has its own number, corresponding to the effective Station DAY and NIGHT COS and Line DAY and NIGHT COS.
3. The maximum length of the numbers that can be entered into the Restriction Table and the Exception Table are 8 and 14 digits, respectively.
4. The DAY & NIGHT COS of the stations and line range from 0 to 7.

**ULT:** All stations can access all CO lines. However, please see the Default Toll Restrictions table in the **FEATURES** section (page 69) for all station and line defaults.

## LEAST COST ROUTING (LCR)

### ACTION

### RESULT

: N E X T

LCR		
BACK	NEXT	SHOW
<input type="text"/>	<input type="text"/>	<input type="text"/>

SHOW

DIGIT COMPARISON		
BACK	NEXT	SHOW
<input type="text"/>	<input type="text"/>	<input type="text"/>

# SYSTEM PROGRAMMING

## 5.5 RESTRICTION CATEGORY, cont'd

<u>ACTION</u>	<u>RESULT</u>										
Press: <b>SHOW</b>	<table border="1"><tr><td>TABLE ENTRY: _</td><td></td><td></td></tr><tr><td>BKSP</td><td><b>SHOW</b></td><td>CHG</td></tr><tr><td><input type="text"/></td><td><input type="text"/></td><td><input type="text"/></td></tr></table>	TABLE ENTRY: _			BKSP	<b>SHOW</b>	CHG	<input type="text"/>	<input type="text"/>	<input type="text"/>	There are 100 total entries for the Digit Comparison Table
TABLE ENTRY: _											
BKSP	<b>SHOW</b>	CHG									
<input type="text"/>	<input type="text"/>	<input type="text"/>									
Press: 001	<table border="1"><tr><td>TABLE ENTRY: 001</td><td></td><td></td></tr><tr><td>BKSP</td><td>SHOW</td><td>CHG</td></tr><tr><td><input type="text"/></td><td><input type="text"/></td><td><input type="text"/></td></tr></table>	TABLE ENTRY: 001			BKSP	SHOW	CHG	<input type="text"/>	<input type="text"/>	<input type="text"/>	(001-I 00)
TABLE ENTRY: 001											
BKSP	SHOW	CHG									
<input type="text"/>	<input type="text"/>	<input type="text"/>									
Press: <b>SHOW</b>	<table border="1"><tr><td>FROM</td><td></td><td></td></tr><tr><td>BACK</td><td>NEXT</td><td>SHOW</td></tr><tr><td><input type="text"/></td><td><input type="text"/></td><td><input type="text"/></td></tr></table>	FROM			BACK	NEXT	SHOW	<input type="text"/>	<input type="text"/>	<input type="text"/>	
FROM											
BACK	NEXT	SHOW									
<input type="text"/>	<input type="text"/>	<input type="text"/>									
Press: <b>SHOW</b>	<table border="1"><tr><td>EMPTY</td><td></td><td></td></tr><tr><td>BACK</td><td>NEXT</td><td>CHG</td></tr><tr><td><input type="text"/></td><td><input type="text"/></td><td><input type="text"/></td></tr></table>	EMPTY			BACK	NEXT	CHG	<input type="text"/>	<input type="text"/>	<input type="text"/>	
EMPTY											
BACK	NEXT	CHG									
<input type="text"/>	<input type="text"/>	<input type="text"/>									
Press: <b>CHG</b>	<table border="1"><tr><td><input type="text"/></td><td><input type="text"/></td><td><input type="text"/></td></tr><tr><td>BKSP</td><td>SAVE</td><td>CHG</td></tr><tr><td><input type="text"/></td><td><input type="text"/></td><td><input type="text"/></td></tr></table>	<input type="text"/>	<input type="text"/>	<input type="text"/>	BKSP	SAVE	CHG	<input type="text"/>	<input type="text"/>	<input type="text"/>	Maximum 14 digits (0-9)
<input type="text"/>	<input type="text"/>	<input type="text"/>									
BKSP	SAVE	CHG									
<input type="text"/>	<input type="text"/>	<input type="text"/>									
Press: 002	<table border="1"><tr><td>002_</td><td></td><td></td></tr><tr><td>BKSP</td><td>SAVE</td><td>CHG</td></tr><tr><td><input type="text"/></td><td><input type="text"/></td><td><input type="text"/></td></tr></table>	002_			BKSP	SAVE	CHG	<input type="text"/>	<input type="text"/>	<input type="text"/>	
002_											
BKSP	SAVE	CHG									
<input type="text"/>	<input type="text"/>	<input type="text"/>									
Press: <b>SAVE</b>	<table border="1"><tr><td>002</td><td></td><td></td></tr><tr><td>BACK</td><td>NEXT</td><td>CHG</td></tr><tr><td><input type="text"/></td><td><input type="text"/></td><td><input type="text"/></td></tr></table>	002			BACK	NEXT	CHG	<input type="text"/>	<input type="text"/>	<input type="text"/>	
002											
BACK	NEXT	CHG									
<input type="text"/>	<input type="text"/>	<input type="text"/>									
Press: <b>NEXT</b>	<table border="1"><tr><td>TO</td><td></td><td></td></tr><tr><td>BACK</td><td>NEXT</td><td>SHOW</td></tr><tr><td><input type="text"/></td><td><input type="text"/></td><td><input type="text"/></td></tr></table>	TO			BACK	NEXT	SHOW	<input type="text"/>	<input type="text"/>	<input type="text"/>	
TO											
BACK	NEXT	SHOW									
<input type="text"/>	<input type="text"/>	<input type="text"/>									

# SYSTEM PROGRAMMING

## RESTRICTION CATEGORY, cont'd

ACTION

RESULT

ss: SHOW

EMPTY		
BACK	NEXT	CHG
_____	_____	_____

ss: CHG

BKSP	SAVE	CHG
_____	_____	_____

Maximum 14 digits (0-9)

ss: 003

003		
BKSP	SAVE	CHG
_____	_____	_____

ss: SAVE

003		
BACK	NEXT	CHG
_____	_____	_____

ss: NEXT

TIME OF DAY LIST		
BACK	NEXT	SHOW
_____	_____	_____

ss: SHOW

MONDAY: NONE		
BACK	NEXT	CHG
_____	_____	_____

NONE/ I-10 (table number)

ss: NEXT

TUESDAY: NONE		
BACK	NEXT	CHG
_____	_____	_____

NONE/ I-10

ss: NEXT

SUNDAY: NONE		
BACK	NEXT	CHG
_____	_____	_____

NONE/ I-10

# SYSTEM PROGRAMMING

## 5.5 RESTRICTION CATEGORY, cont'd

<u>ACTION</u>	<u>RESULT</u>										
Press: <b>NEXT</b>	<table border="1"><tr><td>TABLE ENTRY: _</td><td></td><td></td></tr><tr><td>BKSP</td><td><b>SHOW</b></td><td>CHG</td></tr><tr><td>_____</td><td>_____</td><td>_____</td></tr></table>	TABLE ENTRY: _			BKSP	<b>SHOW</b>	CHG	_____	_____	_____	(001-100)
TABLE ENTRY: _											
BKSP	<b>SHOW</b>	CHG									
_____	_____	_____									
Press: <b>SHIFT</b> key	<table border="1"><tr><td colspan="3">DIGIT COMPARISON</td></tr><tr><td>BACK</td><td>NEXT</td><td>SHOW</td></tr><tr><td>_____</td><td>_____</td><td>_____</td></tr></table>	DIGIT COMPARISON			BACK	NEXT	SHOW	_____	_____	_____	
DIGIT COMPARISON											
BACK	NEXT	SHOW									
_____	_____	_____									
Press: <b>NEXT</b>	<table border="1"><tr><td colspan="3">TIME-DAY TABLES</td></tr><tr><td>BACK</td><td>NEXT</td><td>SHOW</td></tr><tr><td>_____</td><td>_____</td><td>_____</td></tr></table>	TIME-DAY TABLES			BACK	NEXT	SHOW	_____	_____	_____	
TIME-DAY TABLES											
BACK	NEXT	SHOW									
_____	_____	_____									
Press: <b>SHOW</b>	<table border="1"><tr><td colspan="3">TABLE NUMBER: _</td></tr><tr><td>BKSP</td><td>SHOW</td><td>CHG</td></tr><tr><td>_____</td><td>_____</td><td>_____</td></tr></table>	TABLE NUMBER: _			BKSP	SHOW	CHG	_____	_____	_____	There are 10 tables for the Time of Day List Table
TABLE NUMBER: _											
BKSP	SHOW	CHG									
_____	_____	_____									
Press: 01	<table border="1"><tr><td colspan="3">TABLE NUMBER: 01</td></tr><tr><td>BKSP</td><td>SHOW</td><td>CHG</td></tr><tr><td>_____</td><td>_____</td><td>_____</td></tr></table>	TABLE NUMBER: 01			BKSP	SHOW	CHG	_____	_____	_____	(01-10)
TABLE NUMBER: 01											
BKSP	SHOW	CHG									
_____	_____	_____									
Press: <b>SHOW</b>	<table border="1"><tr><td>TABLE ENTRY: _</td><td></td><td></td></tr><tr><td>BKSP</td><td><b>SHOW</b></td><td>CHG</td></tr><tr><td>_____</td><td>_____</td><td>_____</td></tr></table>	TABLE ENTRY: _			BKSP	<b>SHOW</b>	CHG	_____	_____	_____	1-6
TABLE ENTRY: _											
BKSP	<b>SHOW</b>	CHG									
_____	_____	_____									
Press: <b>1</b>	<table border="1"><tr><td>TABLE ENTRY: 1</td><td></td><td></td></tr><tr><td>BKSP</td><td><b>SHOW</b></td><td>CHG</td></tr><tr><td>_____</td><td>_____</td><td>_____</td></tr></table>	TABLE ENTRY: 1			BKSP	<b>SHOW</b>	CHG	_____	_____	_____	
TABLE ENTRY: 1											
BKSP	<b>SHOW</b>	CHG									
_____	_____	_____									
Press: <b>SHOW</b>	<table border="1"><tr><td colspan="3">TIME: NONE</td></tr><tr><td>BACK</td><td>NEXT</td><td>CHG</td></tr><tr><td>_____</td><td>_____</td><td>_____</td></tr></table>	TIME: NONE			BACK	NEXT	CHG	_____	_____	_____	NONE/ 00:00-2359
TIME: NONE											
BACK	NEXT	CHG									
_____	_____	_____									

# SYSTEM PROGRAMMING

## 5.5 RESTRICTION CATEGORY, cont'd

### ACTION

### RESULT

Press: CHG

TIME: _		
BKSP	SAVE	CHG
<input type="text"/>	<input type="text"/>	<input type="text"/>

Press: 0000

TIME: 00:00		
BKSP	SAVE	CHG
<input type="text"/>	<input type="text"/>	<input type="text"/>

Press: SAVE

TIME: 00:00		
BACK	NEXT	CHG
<input type="text"/>	<input type="text"/>	<input type="text"/>

Press: NEXT

POOL LIST: NONE		
BKSP	NEXT	CHG
<input type="text"/>	<input type="text"/>	<input type="text"/>

NONE/ 1-8

Press: NEXT

TABLE ENTRY: _		
BKSP	SHOW	CHG
<input type="text"/>	<input type="text"/>	<input type="text"/>

1 - 6

Press: SHIFT key

TABLE NUMBER: _		
BKSP	SHOW	CHG
<input type="text"/>	<input type="text"/>	<input type="text"/>

01-10

Press: SHIFT key

TIME-DAY TABLES		
BACK	NEXT	SHOW
<input type="text"/>	<input type="text"/>	<input type="text"/>

Press: NEXT

LINE POOLS TABLE		
BACK	NEXT	SHOW
<input type="text"/>	<input type="text"/>	<input type="text"/>

# SYSTEM PROGRAMMING

## 5.5 RESTRICTION CATEGORY, *cont'd*

<u>ACTION</u>	<u>RESULT</u>										
Press: <b>SHOW</b>	<table border="1"><tr><td colspan="3">TABLE ENTRY: _</td></tr><tr><td>BKSP</td><td>SHOW</td><td>CHG</td></tr><tr><td>_____</td><td>_____</td><td>_____</td></tr></table>	TABLE ENTRY: _			BKSP	SHOW	CHG	_____	_____	_____	1-8
TABLE ENTRY: _											
BKSP	SHOW	CHG									
_____	_____	_____									
Press: 1	<table border="1"><tr><td colspan="3">TABLE ENTRY: 1</td></tr><tr><td>BKSP</td><td>SHOW</td><td>CHG</td></tr><tr><td>_____</td><td>_____</td><td>_____</td></tr></table>	TABLE ENTRY: 1			BKSP	SHOW	CHG	_____	_____	_____	
TABLE ENTRY: 1											
BKSP	SHOW	CHG									
_____	_____	_____									
Press: <b>SHOW</b>	<table border="1"><tr><td colspan="3">CHOICE</td></tr><tr><td>BACK</td><td>NEXT</td><td>SHOW</td></tr><tr><td>_____</td><td>_____</td><td>_____</td></tr></table>	CHOICE			BACK	NEXT	SHOW	_____	_____	_____	
CHOICE											
BACK	NEXT	SHOW									
_____	_____	_____									
Press: <b>SHOW</b>	<table border="1"><tr><td colspan="3">CHOICE 1: NONE</td></tr><tr><td>BACK</td><td>NEXT</td><td>CHG</td></tr><tr><td>_____</td><td>_____</td><td>_____</td></tr></table>	CHOICE 1: NONE			BACK	NEXT	CHG	_____	_____	_____	NONE/ 1-8
CHOICE 1: NONE											
BACK	NEXT	CHG									
_____	_____	_____									
Press: <b>CHG</b>	<table border="1"><tr><td colspan="3">CHOICE 1: 1</td></tr><tr><td>BACK</td><td>NEXT</td><td>CHG</td></tr><tr><td>_____</td><td>_____</td><td>_____</td></tr></table>	CHOICE 1: 1			BACK	NEXT	CHG	_____	_____	_____	
CHOICE 1: 1											
BACK	NEXT	CHG									
_____	_____	_____									
Press: <b>NEXT</b>	<table border="1"><tr><td colspan="3">CHOICE 2: NONE</td></tr><tr><td>BACK</td><td>NEXT</td><td>CHG</td></tr><tr><td>_____</td><td>_____</td><td>_____</td></tr></table>	CHOICE 2: NONE			BACK	NEXT	CHG	_____	_____	_____	NONE/ 1-8
CHOICE 2: NONE											
BACK	NEXT	CHG									
_____	_____	_____									
Press: <b>NEXT</b>	<table border="1"><tr><td colspan="3">CHOICE 3: NONE</td></tr><tr><td>BACK</td><td>NEXT</td><td>CHG</td></tr><tr><td>_____</td><td>_____</td><td>_____</td></tr></table>	CHOICE 3: NONE			BACK	NEXT	CHG	_____	_____	_____	NONE/ 1-8
CHOICE 3: NONE											
BACK	NEXT	CHG									
_____	_____	_____									
Press: <b>NEXT</b>	<table border="1"><tr><td colspan="3">CHOICE 4: NONE</td></tr><tr><td>BACK</td><td>NEXT</td><td>CHG</td></tr><tr><td>_____</td><td>_____</td><td>_____</td></tr></table>	CHOICE 4: NONE			BACK	NEXT	CHG	_____	_____	_____	
CHOICE 4: NONE											
BACK	NEXT	CHG									
_____	_____	_____									

# SYSTEM PROGRAMMING

## 5.5 RESTRICTION CATEGORY, cont'd

### ACTION

### RESULT

Press: NEXT

DMT NO.		
BACK	NEXT	SHOW
<input type="text"/>	<input type="text"/>	<input type="text"/>

DMT= Digit Modification Table

press: SHOW

DMT NO. 1: NONE		
BACK	NEXT	CHG
<input type="text"/>	<input type="text"/>	<input type="text"/>

NONE/ 1-8

Press: NEXT

DMT NO. 2: NONE		
BACK	NEXT	CHG
<input type="text"/>	<input type="text"/>	<input type="text"/>

Press: ~~NEXT~~

DMT NO. 3: NONE		
BACK	NEXT	CHG
<input type="text"/>	<input type="text"/>	<input type="text"/>

Press: NEXT

DMT NO. 4: NONE		
BACK	NEXT	CHG
<input type="text"/>	<input type="text"/>	<input type="text"/>

Press: NEXT

TABLE ENTRY: _			
BKSP	SHOW	C	H
<input type="text"/>	<input type="text"/>	<input type="text"/>	<input type="text"/>

1-8

G

Press: SHIFT key

LINE POOLS TABLE			
BACK	NEXT	S	H.O.W
<input type="text"/>	<input type="text"/>	<input type="text"/>	<input type="text"/>

press: NEXT

DGT MODIFICATION		
BACK	NEXT	SHOW
<input type="text"/>	<input type="text"/>	<input type="text"/>

# SYSTEM PROGRAMMING

## 5.5 RESTRICTION CATEGORY, cont'd

<u>ACTION</u>	<u>RESULT</u>	
Press: <b>SHOW</b>	TABLE ENTRY: BKSP <b>SHOW</b> CHG _____	1-8
Press: 1	TABLE ENTRY: 1 BKSP <b>SHOW</b> CHG _____	
Press: <b>SHOW</b>	NONE/ DELETE DGT: NONE BACK <b>NEXT</b> CHG _____	0-12
Press: <b>CHG</b>	DELETE DGT: 1 BACK <b>NEXT</b> CHG _____	
Press: <b>NEXT</b>	INSERT DIGIT BACK <b>NEXT</b> SHOW _____	
Press: <b>SHOW</b>	EMPTY BACK <b>NEXT</b> CHG _____	
Press: <b>CHG</b>	<b>BKSP</b> <b>SAVE</b> CHG _____	Maximum 16 digits, 0-9, Pause ( <b>F70</b> )
Press: <b>F70902</b>	<b>P902</b> BKSP <b>SAVE</b> CHG _____	F= Feature key

# SYSTEM PROGRAMMING

## 1.5 RESTRICTION CATEGORY, cont'd

### ACTION

### RESULT

Press: **SAVE**

P902		
BACK	NEXT	CHG
<input type="text"/>	<input type="text"/>	<input type="text"/>

Press: **NEXT**

TABLE ENTRY:		
BKSP	SHOW	CHG
<input type="text"/>	<input type="text"/>	<input type="text"/>

1-8

Press: **SHIFT key**

DGT MODIFICATION		
BACK	NEXT	SHOW
<input type="text"/>	<input type="text"/>	<input type="text"/>

**NOTE:** In the Digit Comparison Table when in the range between 'FROM' and 'TO', the entry with the higher **priority should** be programmed at the front end of the table. The Digit Comparison Table is checked digit by digit, creating a best-fit algorithm for digit checking.

**DEFAULT:** None

# SYSTEM PROGRAMMING

## 5.6 PERIPHERAL CATEGORY

### ACTION

### RESULT

Press: **NEXT**

6. PERIPHERAL		
BACK	NEXT	SHOW
<input type="text"/>	<input type="text"/>	<input type="text"/>

## 5.6.1 STATION MESSAGE DETAIL RECORDING (SMDR) OUTPUT

### ACTION

### RESULT

Press: **SHOW**

SMDR OUTPUT		
BACK	NEXT	SHOW
<input type="text"/>	<input type="text"/>	<input type="text"/>

Press: **SHOW**

INCOMING CALL: Y		
BACK	NEXT	CHG
<input type="text"/>	<input type="text"/>	<input type="text"/>

Y/N

Press: **NEXT**

ACCOUNT CODE: Y		
BACK	NEXT	CHG
<input type="text"/>	<input type="text"/>	<input type="text"/>

Y/N

Press: **CHG**

ACCOUNT CODE: N		
BACK	NEXT	CHG
<input type="text"/>	<input type="text"/>	<input type="text"/>

Y/N

**DEFAULT:** The SMDR of every type of account code will be printed out.

# SYSTEM PROGRAMMING

## 5.6 PERIPHERAL CATEGORY, cont'd

### 5.6.2 RS232C (RMT) DATA RATE

#### ACTION

#### RESULT

Press: NEXT

RMT X-RATE: 9600		
BACK	NEXT	CHG
<input type="text"/>	<input type="text"/>	<input type="text"/>

110/300/600/1200/2400/4800/  
9600/1 9200 bps

Press: CHG

RMT X-RATE: 19200		
BACK	NEXT	CHG
<input type="text"/>	<input type="text"/>	<input type="text"/>

Press: NEXT

SMDRX_RATE: 9600		
BACK	NEXT	CHG
<input type="text"/>	<input type="text"/>	<input type="text"/>

110/300/600/1200/2400/4800/  
9600/1 9200 bps

Press: CHG

SMDRX_RATE: 19200		
BACK	NEXT	CHG
<input type="text"/>	<input type="text"/>	<input type="text"/>

**NOTE:** Two **RS232C** ports are provided. One is used to serve the DCE terminal, interfacing to a serial printer or data terminal equipment for output of the SMDR, and the other is used in interfacing with a MODEM or data terminal equipment for remote programming.

**DEFAULT:** The data transmission rate is 9600 bits per second.

### 5.6.3 LOUD BELL INTERFACE

#### ACTION

#### RESULT

Press: NEXT

LOUD BELL		
BACK	NEXT	SHOW
<input type="text"/>	<input type="text"/>	<input type="text"/>

# SYSTEM PROGRAMMING

## 5.6 PERIPHERAL CATEGORY, cont'd

<u>ACTION</u>	<u>RESULT</u>										
Press: <b>SHOW</b>	<table border="1"><tr><td>SERVICE: DISABLE</td><td></td><td></td></tr><tr><td>BACK</td><td>NEXT</td><td>CHG</td></tr><tr><td><input type="text"/></td><td><input type="text"/></td><td><input type="text"/></td></tr></table>	SERVICE: DISABLE			BACK	NEXT	CHG	<input type="text"/>	<input type="text"/>	<input type="text"/>	DISABLE/DAY/NIGHT/ALWAYS
SERVICE: DISABLE											
BACK	NEXT	CHG									
<input type="text"/>	<input type="text"/>	<input type="text"/>									
Press: <b>CHG</b>	<table border="1"><tr><td>SERVICE: DAY</td><td></td><td></td></tr><tr><td>BACK</td><td>NEXT</td><td>CHG</td></tr><tr><td><input type="text"/></td><td><input type="text"/></td><td><input type="text"/></td></tr></table>	SERVICE: DAY			BACK	NEXT	CHG	<input type="text"/>	<input type="text"/>	<input type="text"/>	DISABLE/DAY/NIGHT/ALWAYS
SERVICE: DAY											
BACK	NEXT	CHG									
<input type="text"/>	<input type="text"/>	<input type="text"/>									
Press: <b>NEXT</b>	<table border="1"><tr><td>POOL</td><td></td><td></td></tr><tr><td>BACK</td><td>NEXT</td><td>SHOW</td></tr><tr><td><input type="text"/></td><td><input type="text"/></td><td><input type="text"/></td></tr></table>	POOL			BACK	NEXT	SHOW	<input type="text"/>	<input type="text"/>	<input type="text"/>	
POOL											
BACK	NEXT	SHOW									
<input type="text"/>	<input type="text"/>	<input type="text"/>									
Press: <b>SHOW</b>	<table border="1"><tr><td>POOL 1: N</td><td></td><td></td></tr><tr><td>BACK</td><td>NEXT</td><td>CHG</td></tr><tr><td><input type="text"/></td><td><input type="text"/></td><td><input type="text"/></td></tr></table>	POOL 1: N			BACK	NEXT	CHG	<input type="text"/>	<input type="text"/>	<input type="text"/>	Y/N
POOL 1: N											
BACK	NEXT	CHG									
<input type="text"/>	<input type="text"/>	<input type="text"/>									
Press: <b>NEXT</b>	<table border="1"><tr><td>POOL 2: N</td><td></td><td></td></tr><tr><td>BACK</td><td>NEXT</td><td>CHG</td></tr><tr><td><input type="text"/></td><td><input type="text"/></td><td><input type="text"/></td></tr></table>	POOL 2: N			BACK	NEXT	CHG	<input type="text"/>	<input type="text"/>	<input type="text"/>	
POOL 2: N											
BACK	NEXT	CHG									
<input type="text"/>	<input type="text"/>	<input type="text"/>									
Press: <b>NEXT</b>	<table border="1"><tr><td>POOL 8: N</td><td></td><td></td></tr><tr><td>BACK</td><td>NEXT</td><td>CHG</td></tr><tr><td><input type="text"/></td><td><input type="text"/></td><td><input type="text"/></td></tr></table>	POOL 8: N			BACK	NEXT	CHG	<input type="text"/>	<input type="text"/>	<input type="text"/>	
POOL 8: N											
BACK	NEXT	CHG									
<input type="text"/>	<input type="text"/>	<input type="text"/>									
Press: <b>NEXT</b>	<table border="1"><tr><td>LINE</td><td></td><td></td></tr><tr><td>BACK</td><td>NEXT</td><td>SHOW</td></tr><tr><td><input type="text"/></td><td><input type="text"/></td><td><input type="text"/></td></tr></table>	LINE			BACK	NEXT	SHOW	<input type="text"/>	<input type="text"/>	<input type="text"/>	
LINE											
BACK	NEXT	SHOW									
<input type="text"/>	<input type="text"/>	<input type="text"/>									
Press: <b>SHOW</b>	<table border="1"><tr><td>LINE 01: N</td><td></td><td></td></tr><tr><td>BACK</td><td>NEXT</td><td>CHG</td></tr><tr><td><input type="text"/></td><td><input type="text"/></td><td><input type="text"/></td></tr></table>	LINE 01: N			BACK	NEXT	CHG	<input type="text"/>	<input type="text"/>	<input type="text"/>	Y/N
LINE 01: N											
BACK	NEXT	CHG									
<input type="text"/>	<input type="text"/>	<input type="text"/>									

# SYSTEM PROGRAMMING

## 6 PERIPHERAL CATEGORY, cont'd

ACTION

RESULT

ress: NEXT

LINE 02: N		
BACK	NEXT	CHG
_____	_____	_____

ress: NEXT

LINE 06: N		
BACK	NEXT	CHG
_____	_____	_____

ress: CHG

LINE 06: Y		
BACK	NEXT	CHG
_____	_____	_____

ress: NEXT

STATION: NONE		
BACK	NEXT	CHG
_____	_____	_____

ress: CHG

STATION: _____		
BKSP	SAVE	CHG
_____	_____	_____

10-81, i.e., existing station number

ress: 10

STATION: 10		
BKSP	SAVE	CHG
_____	_____	_____

ress: SAVE

STATION: 10		
BACK	NEXT	CHG
_____	_____	_____

- NOTES:**
1. If the Loud Bell function is assigned to a line, the loud bell will be activated with the same alerting cadence as the normal line ring. The Loud Bell will stop upon answering or abandoning the call.
  2. There is only one Loud Bell interface provided.
  3. The Loud Bell can be assigned to more than one line.

**FAULT:** The Loud Bell is not associated with any line, line pool, or station.

# SYSTEM PROGRAMMING

## 5.6 PERIPHERAL CATEGORY, cont'd

### 5.6.4 SINGLE LINE TELEPHONE (SLT) HOOK FLASH TIME

ACTION	RESULT										
Press: NEXT	<table border="1"><tr><td colspan="3">SLT HOOK FLASH</td></tr><tr><td>BACK</td><td>NEXT</td><td>SHOW</td></tr><tr><td><input type="text"/></td><td><input type="text"/></td><td><input type="text"/></td></tr></table>	SLT HOOK FLASH			BACK	NEXT	SHOW	<input type="text"/>	<input type="text"/>	<input type="text"/>	
SLT HOOK FLASH											
BACK	NEXT	SHOW									
<input type="text"/>	<input type="text"/>	<input type="text"/>									
Press: SHOW	<table border="1"><tr><td colspan="3">MIN TIME: 300</td></tr><tr><td>BACK</td><td>NEXT</td><td>CHG</td></tr><tr><td><input type="text"/></td><td><input type="text"/></td><td><input type="text"/></td></tr></table>	MIN TIME: 300			BACK	NEXT	CHG	<input type="text"/>	<input type="text"/>	<input type="text"/>	60/1 00/200/.../1 400 ms
MIN TIME: 300											
BACK	NEXT	CHG									
<input type="text"/>	<input type="text"/>	<input type="text"/>									
Press: CHG	<table border="1"><tr><td colspan="3">MIN TIME: 400</td></tr><tr><td>BACK</td><td>NEXT</td><td>CHG</td></tr><tr><td><input type="text"/></td><td><input type="text"/></td><td><input type="text"/></td></tr></table>	MIN TIME: 400			BACK	NEXT	CHG	<input type="text"/>	<input type="text"/>	<input type="text"/>	
MIN TIME: 400											
BACK	NEXT	CHG									
<input type="text"/>	<input type="text"/>	<input type="text"/>									
Press: NEXT	<table border="1"><tr><td colspan="3">MAX TIME: 900</td></tr><tr><td>BACK</td><td>NEXT</td><td>CHG</td></tr><tr><td><input type="text"/></td><td><input type="text"/></td><td><input type="text"/></td></tr></table>	MAX TIME: 900			BACK	NEXT	CHG	<input type="text"/>	<input type="text"/>	<input type="text"/>	100/200/.../1500 ms
MAX TIME: 900											
BACK	NEXT	CHG									
<input type="text"/>	<input type="text"/>	<input type="text"/>									
Press: CHG	<table border="1"><tr><td colspan="3">MAX TIME: 1000</td></tr><tr><td>BACK</td><td>NEXT</td><td>CHG</td></tr><tr><td><input type="text"/></td><td><input type="text"/></td><td><input type="text"/></td></tr></table>	MAX TIME: 1000			BACK	NEXT	CHG	<input type="text"/>	<input type="text"/>	<input type="text"/>	100/200/.../1500 nls The maximum time must always be greater than the minimum time
MAX TIME: 1000											
BACK	NEXT	CHG									
<input type="text"/>	<input type="text"/>	<input type="text"/>									

- NOTES:**
1. The **maximum** hook flash time is always greater than the minimum hook flash time.
  2. This feature is to be used with single line telephone call operations, such as Call Hold and Hold Retrieve.
  3. After changing the minimum time, always recheck the maximum time. The system may have increased it to assure that it is greater than the minimum time. You may need to change the maximum time.

**DEFAULT:** The default hook flash time ranges from a minimum of 300 ms to a maximum of 900 ms.

# SYSTEM PROGRAMMING

## PERIPHERAL CATEGORY, cont'd

### 5 VOICE MAIL

#### ACTION

#### RESULT

s: NEXT

VOICE MAIL		
BACK	NEXT	SHOW
<input type="text"/>	<input type="text"/>	<input type="text"/>

s: SHOW

REASON FOR CALL		
BACK	NEXT	SHOW
<input type="text"/>	<input type="text"/>	<input type="text"/>

s: SHOW

BUSY EXT: 9*1		
BACK	NEXT	CHG
<input type="text"/>	<input type="text"/>	<input type="text"/>

EXT= External

s: CHG

BUSY EXT: <u>    </u>		
BKSP	SAVE	CHG
<input type="text"/>	<input type="text"/>	<input type="text"/>

s: 123

BUSY EXT: 123		
BKSP	SAVE	CHG
<input type="text"/>	<input type="text"/>	<input type="text"/>

Maximum of 5 digits  
(0-9, \*, #, A, B, C, D)

s: SAVE

BUSY EXT: 123		
BACK	NEXT	CHG
<input type="text"/>	<input type="text"/>	<input type="text"/>

s: NEXT

DIRECT EXT: 9		
BACK	NEXT	CHG
<input type="text"/>	<input type="text"/>	<input type="text"/>

s: NEXT

NO-ANS EXT: 9*2		
BACK	NEXT	CHG
<input type="text"/>	<input type="text"/>	<input type="text"/>

# SYSTEM PROGRAMMING

## 5.6 PERIPHERAL CATEGORY, conf'd

<u>ACTION</u>	<u>RESULT</u>										
Press: <b>NEXT</b>	<table border="1"><tr><td colspan="3">BUSY INT: 9*1</td></tr><tr><td>BACK</td><td>NEXT</td><td>CHG</td></tr><tr><td><input type="text"/></td><td><input type="text"/></td><td><input type="text"/></td></tr></table>	BUSY INT: 9*1			BACK	NEXT	CHG	<input type="text"/>	<input type="text"/>	<input type="text"/>	INT= Internal
BUSY INT: 9*1											
BACK	NEXT	CHG									
<input type="text"/>	<input type="text"/>	<input type="text"/>									
Press: <b>NEXT</b>	<table border="1"><tr><td colspan="3">DIRECT INT: 9</td></tr><tr><td>BACK</td><td>NEXT</td><td>CHG</td></tr><tr><td><input type="text"/></td><td><input type="text"/></td><td><input type="text"/></td></tr></table>	DIRECT INT: 9			BACK	NEXT	CHG	<input type="text"/>	<input type="text"/>	<input type="text"/>	
DIRECT INT: 9											
BACK	NEXT	CHG									
<input type="text"/>	<input type="text"/>	<input type="text"/>									
Press: <b>NEXT</b>	<table border="1"><tr><td colspan="3">NO-ANS INT: 9*2</td></tr><tr><td>BACK</td><td>NEXT</td><td>CHG</td></tr><tr><td><input type="text"/></td><td><input type="text"/></td><td><input type="text"/></td></tr></table>	NO-ANS INT: 9*2			BACK	NEXT	CHG	<input type="text"/>	<input type="text"/>	<input type="text"/>	
NO-ANS INT: 9*2											
BACK	NEXT	CHG									
<input type="text"/>	<input type="text"/>	<input type="text"/>									
Press: <b>NEXT</b>	<table border="1"><tr><td colspan="3">ICM CALL: *</td></tr><tr><td>BACK</td><td>NEXT</td><td>CHG</td></tr><tr><td><input type="text"/></td><td><input type="text"/></td><td><input type="text"/></td></tr></table>	ICM CALL: *			BACK	NEXT	CHG	<input type="text"/>	<input type="text"/>	<input type="text"/>	Maximum of 5 digits (0-9,*,#,A,B,C,D)
ICM CALL: *											
BACK	NEXT	CHG									
<input type="text"/>	<input type="text"/>	<input type="text"/>									
Press: <b>NEXT</b>	<table border="1"><tr><td colspan="3">XFR CALL: EMPTY</td></tr><tr><td>BACK</td><td>NEXT</td><td>CHG</td></tr><tr><td><input type="text"/></td><td><input type="text"/></td><td><input type="text"/></td></tr></table>	XFR CALL: EMPTY			BACK	NEXT	CHG	<input type="text"/>	<input type="text"/>	<input type="text"/>	Maximum of 5 digits (0-9,*,#,A,B,C,D)
XFR CALL: EMPTY											
BACK	NEXT	CHG									
<input type="text"/>	<input type="text"/>	<input type="text"/>									
Press: <b>NEXT</b>	<table border="1"><tr><td colspan="3">DISCONNECT: D</td></tr><tr><td>BACK</td><td>NEXT</td><td>CHG</td></tr><tr><td><input type="text"/></td><td><input type="text"/></td><td><input type="text"/></td></tr></table>	DISCONNECT: D			BACK	NEXT	CHG	<input type="text"/>	<input type="text"/>	<input type="text"/>	Maximum of 5 digits (0-9,*,#,A,B,C,D)
DISCONNECT: D											
BACK	NEXT	CHG									
<input type="text"/>	<input type="text"/>	<input type="text"/>									
Press: <b>NEXT</b>	<table border="1"><tr><td colspan="3">INITIAL: EMPTY</td></tr><tr><td>BACK</td><td>NEXT</td><td>CHG</td></tr><tr><td><input type="text"/></td><td><input type="text"/></td><td><input type="text"/></td></tr></table>	INITIAL: EMPTY			BACK	NEXT	CHG	<input type="text"/>	<input type="text"/>	<input type="text"/>	Maximum of 5 digits (0-9,*,#,A,B,C,D)
INITIAL: EMPTY											
BACK	NEXT	CHG									
<input type="text"/>	<input type="text"/>	<input type="text"/>									
Press: <b>NEXT</b>	<table border="1"><tr><td colspan="3">VM ACCESS COND</td></tr><tr><td>BACK</td><td>NEXT</td><td>SHOW</td></tr><tr><td><input type="text"/></td><td><input type="text"/></td><td><input type="text"/></td></tr></table>	VM ACCESS COND			BACK	NEXT	SHOW	<input type="text"/>	<input type="text"/>	<input type="text"/>	
VM ACCESS COND											
BACK	NEXT	SHOW									
<input type="text"/>	<input type="text"/>	<input type="text"/>									

# SYSTEM PROGRAMMING

## 6 PERIPHERAL CATEGORY, cont'd

### ACTION

### RESULT

ESS: SHOW

REASON: N		
BACK	NEXT	CHG
<input type="text"/>	<input type="text"/>	<input type="text"/>

Y/N

ESS: CHG

REASON: Y		
<del>BACK</del>	<del>NEXT</del>	CHG
<input type="text"/>	<input type="text"/>	<input type="text"/>

ESS: NEXT

ORIGINATOR: Y		
BACK	NEXT	CHG
<input type="text"/>	<input type="text"/>	<input type="text"/>

Y/N

**NOTES:** 1. The allowed programmable digits include 0-9, \*, #, and extended DTMF digits 'A', 'B', 'C', and 'D', which can be entered using the following method:

'A'- F1  
'B'- F2  
'C'- F3  
'D'- F4

- For more detailed information, please refer to the Feature Operation User's Guide, End to End Signaling.
- The abbreviation EXT stands for external while INT stands for internal.

**FAULT:** 1. VM access condition is NO for reason and originator.  
2. The following are the default VM reasons for call:

BUSY EXT/INT-	9*1
DIRECT EXT/INT-	9
NO ANS EXT/INT-	9*2
DISCONNECT DGT-	D
TRANSFER CALL-	EMPTY
ICM CALL-	*
INITIAL CALL-	EMPTY

# SYSTEM PROGRAMMING

## 5.6 PERIPHERAL CATEGORY, cont'd

### 5.6.6 MODEM SETUP

<u>ACTION</u>	<u>RESULT</u>							
Press: <b>NEXT</b>	<table border="1"><tr><td colspan="3">MODEM SETUP</td></tr><tr><td>BACK</td><td>NEXT</td><td>SHOW</td></tr></table>	MODEM SETUP			BACK	NEXT	SHOW	
MODEM SETUP								
BACK	NEXT	SHOW						
Press: <b>SHOW</b>	<table border="1"><tr><td colspan="3">AT&amp;FE0&amp;Q0S0=3</td></tr><tr><td>BACK</td><td>NEXT</td><td>CHG</td></tr></table>	AT&FE0&Q0S0=3			BACK	NEXT	CHG	
AT&FE0&Q0S0=3								
BACK	NEXT	CHG						
Press: <b>CHG</b>	<table border="1"><tr><td><u>B</u>KSP</td><td>SAVE</td><td>CHG</td></tr></table>	<u>B</u> KSP	SAVE	CHG	Maximum of 16 characters			
<u>B</u> KSP	SAVE	CHG						
Press: <b>***#333#33#0# 777#0#***#1111# ***#9#</b>	<table border="1"><tr><td colspan="3">&amp;FE0S0=1&amp;W</td></tr><tr><td>BKSP</td><td>SAVE</td><td>CHG</td></tr></table>	&FE0S0=1&W			BKSP	SAVE	CHG	
&FE0S0=1&W								
BKSP	SAVE	CHG						
Press: <b>SAVE</b>	<table border="1"><tr><td colspan="3">&amp;FE0S0=1&amp;W</td></tr><tr><td>BACK</td><td>NEXT</td><td>CHG</td></tr></table>	&FE0S0=1&W			BACK	NEXT	CHG	
&FE0S0=1&W								
BACK	NEXT	CHG						

**NOTES:** 1. Characters are entered by repeatedly pressing a key on the phone's keypad. For example, the **first** press of the **"2"** key represents an **"A"**, the second press represents a **"B"**, then **"C"**, then **"2"**, which is the keypad digit itself. Other keys work similarly, with the following additional characters available:

"1" key: Q, Z, /, 1  
"\*" key: ?, =, &, \$  
"0" key: 0, +

2. Press the **"#"** key after each character (including the last one) to save it and advance to the next space while programming.

**DEFAULT:** The modem **seti=up** string is **AT&FE&Q0S0=3**

# SYSTEM PROGRAMMING

## PERIPHERAL CATEGORY, cont'd

### 7 LOOP BREAK DETECTION

ACTION

RESULT

is: NEXT

LOOP BREAK	NEXT	SHOW
BACK	NEXT	SHOW

s: SHOW

SERVICE: ENABLE	NEXT	CHG
BACK	NEXT	CHG

ENABLE/DISABLE

s: CHG

SERVICE: DISABLE	NEXT	CHG
BACK	NEXT	CHG

s: NEXT

MIN BREAK: 350	NEXT	C H G
BACK	NEXT	C H G

300/350/400/.../900 ms

s: CHG

MIN BREAK: 400	NEXT	CHG
BACK	NEXT	CHG

- ES: 1. If the line is connected to the VM port and a break signal is detected by the system, then the system has the capability of sending a 'DISCONNECT' message to the VM port to signal that the line has hung up. See Voice Mail (56.5) for programming the 'REASON' header.
2. If Loop Break Detection is enabled, the system will drop held calls if a Central Office Loop Break signal is detected. For more information, see **HOLD ABANDON** in the FEATURES section.

AULT: Loop Break Detection is enabled and the minimum break time is 350 ms.

---

# SYSTEM PROGRAMMING

---

## 5.6 PERIPHERAL CATEGORY, cont'd

ACTION

RESULT

Press: NEXT

1. SET		
BACK	NEXT	SHOW
<input type="text"/>	<input type="text"/>	<input type="text"/>

**NOTE:** You will be returned to the beginning of the programming menu.



# REMOTE SYSTEM PROGRAMMING

## BLE OF CONTENTS

INTRODUCTION .....	3
<b>GENERAL INFORMATION</b> .....	<b>4</b>
2.1 SCREEN DISPLAY STRUCTURE .....	4
2.2 SYSTEMSTARTUP .....	6
2.3 MAIN MENU .....	6
<b>2.4 FUNCTION KEYS</b> .....	<b>10</b>
2.5 SYSTEM HELP MESSAGE .....	11
2.6 SYSTEM STATUS .....	12
<b>DATABASE PROGRAMMING</b> .....	<b>13</b>
3.1 CHANGING AND SAVING TO A DATABASE .....	13
3.2 DATABASE FUNCTION GROUP .....	14
3.2.1 LINE ASSIGNMENT .....	14
3.2.2 RING ASSIGNMENT .....	15
▪ DAY RING .....	16
▪ NIGHTRING .....	17
3.2.3 STATION I .....	18
3.2.4 STATION II .....	19
3.2.5 STATION III .....	20
3.2.6 STATION IV .....	21
3.2.7 LINE I .....	22
3.2.8 LINE II .....	23
3.2.9 SYSTEM I .....	24
3.2.10 SYSTEM II .....	25
3.2.11 SYSTEM III .....	26
3.2.12 MONITOR PASSWORD .....	27
3.2.13 BOSS/SECRETARY .....	28
3.2.14 VOICEMAIL .....	29
3.2.15 DISA .....	30
3.2.16 DISA ACCESS CODE .....	31
3.2.17 EXTERNAL CALL FORWARD (ECF) .....	32
3.2.18 MESSAGES .....	33
3.2.19 SYSTEM SPEED DIALING (SPD) .....	34
<b>3.2.20 TOLL RESTRICTION</b> .....	<b>36</b>
. RESTRICTION TABLE .....	37
▪ EXCEPTION TABLE .....	38
3.2.21 LEAST COST ROUTING (LCR) .....	39
. DIGIT COMPARISON TABLE .....	40
. TIME OF DAY TABLE .....	41
▪ LINE POOLS TABLE .....	43
▪ DIGIT MODIFICATION TABLE .....	44
3.2.22 HUNT GROUP .....	45
3.2.23 FEATURE KEY PROGRAMMING .....	46
3.2.24 LOUDBELL .....	50

---

# REMOTE SYSTEM PROGRAMMING

---

## TABLE OF CONTENTS, cont'd

4. DATABASE COMMUNICATION TO THE KSU .....	
4.1 INSTALLATION REQUIREMENTS. ....	
4.1.1 ON-SITE PROGRAMMING .....	
4.1.2 OFF-SITE PROGRAMMING .....	
4.2 RS232C PORT SETUP .....	
4.3 MODEM SETUP, DIALING AND LINKING .....	
4.4 SOFTWARE CONNECTION TO THE KSU .....	
4.5 SENDING DATA TO THE KSU .....	
4.6 RECEIVING DATA FROM THE KSU .....	
4.7 BACKING UP (AND RESTORING) KSU SETTINGS .....	
4.8 DISCONNECTING .....	
4.9 POTENTIAL PROBLEMS .....	

---

# REMOTE SYSTEM PROGRAMMING

---

## I. INTRODUCTION

The Remote System Programming package is designed as a tool to remotely program the database of the ANDMARK DIGITAL KEY TELEPHONE SYSTEM through the use of a personal computer (PC).

When a PC is connected to the system directly through an RS232C port or through a modem link, extensive changes/modifications to the system database can be made on site or remotely through the PC. In addition, the PC is also capable of uploading the current system database to the PC for backup.

This package contains programming instructions for an IBM PC or compatible computer (PC/XT/AT).

Any PC standard serial port (25 pin or 9 pin) may be used. A cable will be needed to connect the PC port to the KSU's O-pin port (for on-site programming) or to a modem (for off-site programming).

If using a modem, a special cable is also needed to connect the modem to the KSU. See section 4.3, MO-DEM SETUP, for further description.

To use this program, please include the command

**"DEVICE=d:\xxx\ANSI.SYS"**

in your "config.sys" file, where:

d is the disk drive where "ANSI.SYS" is located, and

xxx is the path where "ANSI.SYS" is located.

You may remove the command when finished programming. As an alternative, you may create a bootable floppy with the altered config.sys file and start up your computer from the disk.

## 2. GENERAL INFORMATION

### 2.1 SCREEN DISPLAY STRUCTURE

All the system menus and data fields are organized and displayed on screens for convenient usage. The data shown on the screen diagrams represent the default values for that particular feature category. The main menu (Figure 2.4, page 8) is divided into submenus, each of which refers to another menu or data screen. Figure 2.1, below, illustrates the structure of the menu system. The menu screens are framed by a single line while the data screens have a double line frame.

The main menu has multiple submenu options; by pressing the corresponding alphabetical key, the desired submenu screen will appear.

To exit any submenu screen, simply press the Esc key.

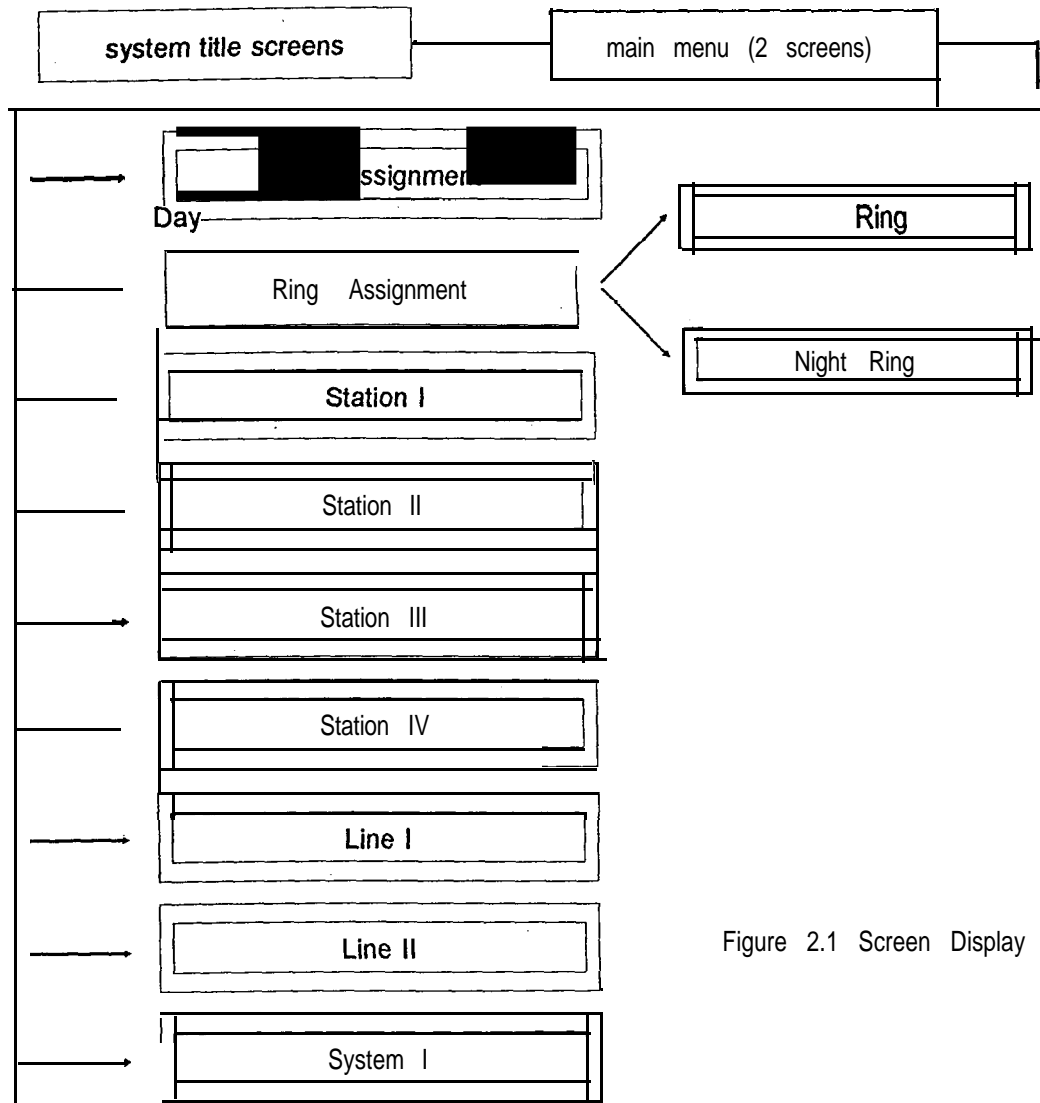

Figure 2.1 Screen Display Structure

# REMOTE SYSTEM PROGRAMMING

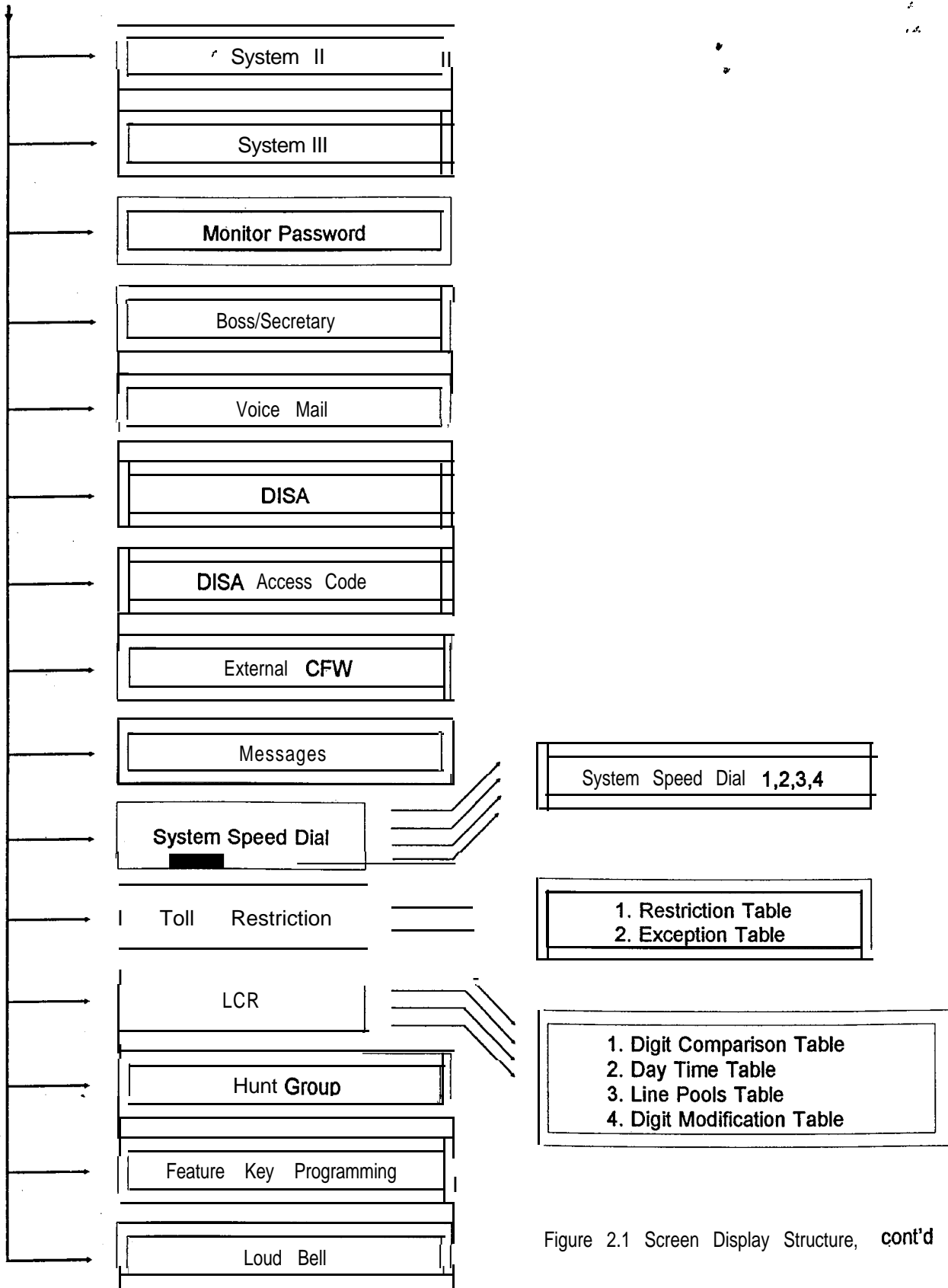

Figure 2.1 Screen Display Structure, cont'd

---

# REMOTE SYSTEM PROGRAMMING

## 2. GENERAL INFORMATION, cont'd

### 2.2 SYSTEM STARTUP

**Insert** the Remote Programming diskette into your disk drive. Choose (type) the drive in which you have your disk (usually a: or b:) at the DOS prompt. You may also copy all the files from your **diskette** onto the hard drive, then switch to the hard drive directory.

To start up the program, type SWB after the DOS prompt and press the ENTER (or RETURN) key. A screen similar to the one depicted in Figure 2.2 should appear.

After entering the correct password (the default password is '00000000'), a **welcome** and copyright message is displayed on the screen, and the option to change the password is displayed, as shown in Figure 2.3.

If you have forgotten the password, you may reset it to the default value ('00000000'). Type **RESTOR** at the DOS prompt and press the ENTER key. Enter the path name and directory containing the programming files and press ENTER to restore the default password.

---

# LANDMARK

Revision : R12UW0.FXX

Welcome to SWB-LANDMARK Remote Programming

Please Enter The Password  
XXXXXXXXXX

Figure 2.2 Startup Message Menu

# REMOTE SYSTEM PROGRAMMING

## 2. GENERAL INFORMATION, cont'd

# LANDMARK

Revision : R12UW0.FXX

Welcome to SWB-LANDMARK Remote Programming

Change The Password (Y/N)

Figure 2.3 Startup Message Menu

If you choose to change the password, three (3) subsequent screens will appear. They will all be similar to Figure 2.3, but the message box will contain a different messages for each screen:

1. Enter Y (yes) in Figure 2.3 and the following message box will be displayed.

Type The New Password  
XXXXXXXX

2. Type in the new password and press ENTER. You will be asked to confirm the new password.

Confirm The New Password  
XXXXXXXX

3. Enter the password again and press ENTER. You will hear a confirmation tone and see a screen confirming your success.

Success  
Press Any Key To Continue

NOTE: If you fail to confirm the new password or make a mistake while typing it in, the screen will display 'Password Mismatch' and bring you to the Main Menu (Figure 2.4) without changing the password.

# REMOTE SYSTEM PROGRAMMING

## 2. GENERAL INFORMATION, cont'd

### 2.3 MAIN MENU

The two main menu screens are shown in Figures 2.4 and 2.5. These two screens are alternately displayed by toggling the PgDn and PgUp keys. The various types of system database screens are classified into 24 function groups as listed in the main menu screens.

LANDMARK KSU Revision <b>K12UW0.FXX</b>		
<b>Esc-Exit</b>	Disconnected	03-02-1 995 08:51:0
<b>Main Menu : [1/2]</b>		
A. Line Assignment	E. Station III Call Forward	H. Line II Private To Delayed Ring
<b>B. Ring Assignment</b>	F. Station IV Set Position Mail Box User Name <b>DSS/BLF For</b>	I. System I Service Mode Hour Mode RMT X-Rate SMDR X-Rate SMDR Output VM Hunt Group <b>DSS/SPD</b> Priority Supervised XFR Ring On Talk One Touch' XFR
C. Station I Day Class Night Class Set Group No. Zone No.	G. Line I Dialing Line Type Line Pool Day Class Night Class Privacy Hunt Group Ans	
D. Station II LCR Enable ICM Call Type User Password		
<b>F1-Help F2-Save-N F3-RCV F4-Send F5-Connect F6-Disc F7-BkUp F8-RS232C F9-Mod</b>		

Figure 2.4 Main Menu Screen I

# REMOTE SYSTEM PROGRAMMING

## 2. GENERAL INFORMATION, cont'd

A function group is accessed by choosing its letter from the main menu screen. **Note** that all **options** can be selected from either of the two main menu screens.

LANDMARK KSU Revision K12UW0.FXX		
Esc-Exit	Disconnected	03-02-1995 08:51:02
Main Menu : [2/2]		
J. System II	L. Monitor Password	U. LCR
PBX Code		
Attendant	M. Boss/Secretary	V. Hunt Group
Night Start	N. Voice Mail	W. Feature Key Programming
Night End		
System Alarm	O. DISA	X. Loud Bell
MODEM Setup		
K. System III	P. DISA Access Code	
Flash Time		
Recall Rings	Q. External CFW	
Pause Time		
Tone Time	R. Messages	
Long Tones		
SLT Hook Flash	S. System Speed Dialing	
VM Header Timing		
Auto Busy Redial	T. Toll Restrictions	
Loop Break		
F1-Help F2-Save-N F3-RCV F4-Send F5-Connect F6-Disc F7-BkUp F8-RS232C F9-Modem		

Figure 2.5 Main Menu Screen II

---

# REMOTE SYSTEM PROGRAMMING

## 2. GENERAL INFORMATION, *cont'd*

### 2.4 FUNCTION KEYS

There is a function key list displayed at the bottom of every screen, except for the system startup message screens. This list corresponds to the function keys (**F1-F9**) and **Esc** key (in the upper left hand corner of every screen display) on the PC's keyboard. They are used as follows:

<b>F1</b> - Help	displays function key description
F2 - Save-Y/Save-N	save or do not save the database to a PC floppy or hard disk
F3 - RCV	receive database from KSU
F4 - Send	send database to KSU
<b>F5</b> - Connect	send connect request to KSU for communication between PC and KSU
F6 - Disc	send disconnect request to KSU to terminate the communication
F7 - BkUp	Backup/Restore the database file
F8 - RS232C	set the related parameters for the communication port
F9 - Modem	set up modem if there will be a remote connection by modem
Esc - Exit	escape the function or exit the screen

An explanation of how to get this help list to display on the computer screen (function key F1) is explained in detail in section 2.5, SYSTEM HELP MESSAGE. More details on how to save database changes (function key F2) can be found in section 3.1, CHANGING AND SAVING TO A DATABASE. The function keys F3 through **F9** are further explained in section 4, DATABASE COMMUNICATION TO THE KSU.

# REMOTE SYSTEM PROGRAMMING

## 2. GENERAL INFORMATION, con t'd

### 2.5 SYSTEM HELP MESSAGE

Help messages are available to the user by pressing the **F1** function key. See Figures 2.6 and 2.7 for a complete overview of the help list (two screens). Use the PgUp and PgDn keys to toggle between the two available screens.

LANDMARK KSU Revision **K1 2UW0.FXX**

Esc-Exii                      Disconnected                      03-02-1 995 08:51:02

Main Menu : [1/2]

Keyword	Description	Page : [1/2]
<b>F1 -Help</b>	displays function key description	
<b>F2-Save-Y/Save-N</b>	saves or does not save the current database	
<b>F3-RCV</b>	receive database from the KSU	
<b>F4-Send</b>	send database to the KSU	
<b>F5-Connect</b>	send a connect request to the KSU for communication 'between the PC and the KSU	
<b>F6-Disc</b>	send a disconnect request to the KSU in order to terminate the communication	
<b>F7-BkUp</b>	backup/restore database files	
<b>F8-RS232C</b>	set the parameters for the communication port	
<b>F9-Modem</b>	connect the KSU via modem to a PC	
<b>F1 O-None/Empty</b>	set the data to be none/empty	

<more> . . . .Please press any key !!

**F1-Help   F2-Save-N   F3-RCV   F4-Send   F5-Connect   F6-Disc   F7-BkUp   F8-RS232C   F9-Modem**

Figure 2.6 Help Message Screen I

# REMOTE SYSTEM PROGRAMMING

## 2. GENERAL INFORMATION, cont'd

LANDMARK KSU Revision K1 2UW0.FXX

Esc-Exit                      Disconnected                      03-02-1 995 08:51:02

Main Menu : [2/2]

Keyword	Description	Page : [2/2]
Up Arrow	move the cursor above the current text	
Down Arrow	move the cursor below the current text	
Left Arrow	move the cursor to the left (preceding) text	
Right Arrow	move the cursor to the right (next) text	
Del	deletes the text at the cursor	
Return [Enter]	cycles through the variables in the field	
Esc-Exit	escapes the current function or exits the screen	

Please press any key !!

F1-Help F2-Save-N F3-RCV F4-Send F5-Connect F6-Disc F7-BkUp F8-RS232C F9-Mode

Figure 2.7 Help Message Screen II

### 2.6 SYSTEM STATUS

Before data can be transmitted between a PC and the KSU, a link must be established. The system provides a Connect/Disconnect message box on the top of all screens, except for the system startup menu screens, to indicate the status of the connection.

In addition, the KSU Software Revision code and the system time are always displayed at the top of screen.

---

# REMOTE SYSTEM PROGRAMMING

## 3. DATABASE PROGRAMMING

### 3.1 CHANGING AND SAVING TO A DATABASE

A function group is selected from one of the main menu screens by pressing the corresponding alphabetic key at any time. All data variables of the selected function group are displayed on the data screen. Changes to the screen are made as follows:

- . press the **PgUp** or **PgDn** keys to toggle through data screens if there are more than one
- . use the **ARROW** (key numbers 2, **4**, **6**, and 8 on the numeric computer keypad) **keys** to move the cursor around the data field
- press **ENTER** key to cycle through the variable in the field
  - Or, in case of a numerical field,
- enter the desired digits
  - Or, in case of a character field,
- . enter the desired letters/digits/symbols/spaces

A database screen can be saved on disk as follows:

Choose the 'Save-Y' option by pressing the **F2** key (it is 'Save-N' by default). Press the **Esc** key to save the current database settings on the screen to a disk file. Any previous data on the disk will be overwritten with the new settings.

If 'Save-N' option is engaged while changing or reviewing a database screen, the user will be asked to save or abandon the database screen after **Esc** key is pressed.

# REMOTE SYSTEM PROGRAMMING

## 3. DATABASE PROGRAMMING, cont'd

### 3.2 DATABASE FUNCTION GROUP

#### 3.2.1 LINE ASSIGNMENT

This function allows access to the flexible C.O. line assignment data for all stations. Figure 3.1 shows the format of the line assignment data screen. The data field options are 'Yes' or 'No' for enabling or disabling any of the 6 available lines at each individual station.

The Set column lists the station numbers, which by default have a one-to-one correlation with the key system station **port** numbers; the station port numbers, located in the parentheses, never change. **Not** that four screens are required for programming Line Assignment, which can be toggled through by **usi** the **PgUp** or **PgDn** keys.

Changes to the screen database settings may be made as follows:

- press the **PgUp** or **PgDn** keys to select the desired page
- use the **ARROW** keys to move cursor to the desired data field
- use the **ENTER** key to cycle through the data options for the field variable

Esc-Exit	LANDMARK KSU Revision K12UW0.FXX											03-02-1995 08:51:0
	Disconnected											
Line Assignment : [1/4]												
Set	Ln1	Ln2	Ln3	Ln4	<b>Ln5</b>	Ln6	Ln7	Ln8	<b>Ln9</b>	<b>Ln10</b>	Ln11	Ln12
10(10)	Yes	Yes	Yes	Yes	Yes	Yes	Yes	Yes	Yes	Yes	Yes	Yes
11(11)	Yes	Yes	Yes	Yes	Yes	Yes	Yes	Yes	Yes	Yes	Yes	Yes
12(12)	Yes	Yes	Yes	Yes	Yes	Yes	Yes	Yes	Yes	Yes	Yes	Yes
13(13)	Yes	Yes	Yes	Yes	Yes	Yes	Yes	Yes	Yes	Yes	Yes	Yes
14(14)	Yes	Yes	Yes	Yes	Yes	Yes	Yes	Yes	Yes	Yes	Yes	Yes
15(15)	Yes	Yes	Yes	Yes	Yes	Yes	Yes	Yes	Yes	Yes	Yes	Yes
16(16)	Yes	Yes	Yes	Yes	Yes	Yes	Yes	Yes	Yes	Yes	Yes	Yes
17(17)	Yes	Yes	Yes	Yes	Yes	Yes	Yes	Yes	Yes	Yes	Yes	Yes
18(18)	Yes	Yes	Yes	Yes	Yes	Yes	Yes	Yes	Yes	Yes	Yes	Yes
19(19)	Yes	Yes	Yes	Yes	Yes	Yes	Yes	Yes	Yes	Yes	Yes	Yes
20(20)	Yes	Yes	Yes	Yes	Yes	Yes	Yes	Yes	Yes	Yes	Yes	Yes
21(21)	Yes	Yes	Yes	Yes	Yes	Yes	Yes	Yes	Yes	Yes	Yes	Yes
22(22)	Yes	Yes	Yes	Yes	Yes	Yes	Yes	Yes	Yes	Yes	Yes	Yes
23(23)	Yes	Yes	Yes	Yes	Yes	Yes	Yes	Yes	Yes	Yes	Yes	Yes
24(24)	Yes	Yes	Yes	Yes	<b>Yes</b>	Yes	Yes	Yes	Yes	Yes	Yes	Yes
25(25)	Yes	Yes	Yes	Yes	Yes	Yes	Yes	Yes	Yes	Yes	Yes	Yes

Figure 3.1 Line Assignment Data Screen

# REMOTE SYSTEM PROGRAMMING

## 3. DATABASE PROGRAMMING, cont'd

### 3.2.2 RING ASSIGNMENT

This function allows access to the ring assignment data for all stations. Figure 3.2 shows the format of the ring assignment data screen. The data field options are 'Yes' or 'No' for enabling or disabling any of the stations' ring assignment.

The Set column lists the station numbers, which by default have a one-to-one correlation with the key system station port numbers; the station port numbers, in the parentheses, never change. Note that four screens are required for both Day Ring programming and Night Ring programming (Figures 3.3 and 3.4, respectively), which can be toggled through by using the **PgUp** or **PgDn** keys.

Choose a menu category as follows:

- select Day Ring or Night Ring (see Figure 3.2 below)

The screenshot shows a terminal window with the following text:

```
LANDMARK KSU Revision K12UW0.FXX  
Esc-Exit Disconnected 03-02-1995 08:51:02
```

In the center of the screen, there is a rectangular box containing the text:

```
Ring Assignment:  
1. Day Ring  
2. Night Ring
```

At the bottom of the screen, there is a black bar with white text listing function keys: **F1-Help F2-Save-N F3-RCV F4-Send F5-Connect F6-Disc F7-BkUp F8-RS232C F9-Modem**

Figure 3.2 Ring Assignment Screen I

# REMOTE SYSTEM PROGRAMMING

## 3. DATABASE PROGRAMMING, cont'd

### DAY RING

The following screen shows the default ring assignments for each line and station as programmed for Day Ring.

Changes to the screen database settings may be made as follows:

- . press the PgUp or PgDn keys to select the desired page
- . use the ARROW keys to move cursor to the desired data field
- . use the ENTER key to cycle through the data options for the field variable

LANDMARK KSU Revision K12UW0.FXX												
Esc-Exit		Disconnected							03-02-1995 08:51:02			
Ring Assignment : [1/4] - Day Ring												
Set	Ln1	Ln2	Ln3	Ln4	Ln5	Ln6	Ln7	Ln8	Ln9	Ln10	Ln11	Ln12
10(10)	Yes	Yes	Yes	Yes	Yes	Yes	Yes	Yes	Yes	Yes	Yes	Yes
11(11)	No	No	No	No	No	No	No	No	No	No	No	No
12(12)	No	No	No	No	No	No	No	No	No	No	No	No
13(13)	No	No	No	No	No	No	No	No	No	No	No	No
14(14)	No	No	No	No	No	No	No	No	No	No	No	No
15(15)	No	No	No	No	No	No	No	No	No	No	No	No
16(16)	No	No	No	No	No	No	No	No	No	No	No	No
17(17)	No	No	No	No	No	No	No	No	No	No	No	No
18(18)	No	No	No	No	No	No	No	No	No	No	No	No
19(19)	No	No	No	No	No	No	No	No	No	No	No	No
20(20)	No	No	No	No	No	No	No	No	No	No	No	No
21(21)	No	No	No	No	No	No	No	No	No	No	No	No
22(22)	No	No	No	No	No	No	No	No	No	No	No	No
23(23)	No	No	No	No	No	No	No	No	No	No	No	No
24(24)	No	No	No	No	No	No	No	No	No	No	No	No
25(25)	No	No	No	No	No	No	No	No	No	No	No	No

F1-Help F2-Save-N F3-RCV F4-Send F5-Connect F6-Disc F7-BkUp F8-RS232C F9-Modem

Figure 3.3 Ring Assignment Screen II

# REMOTE SYSTEM PROGRAMMING

## ATADBASE PROGRAMMING, conf'd

### NIGHT RING

The following screen shows the default ring assignments for each line and station as programmed for Night Ring.

Changes to the screen database settings may be made as follows:

- press the **PgUp** or **PgDn** keys to select the desired page
- use the **ARROW** keys to move cursor to the desired data field
- use the **ENTER** key to cycle through the data options for the field variable

LANDMARK KSU Revision **K12UW0.FXX**

Exit

Disconnected

03-02-1 995 08:51:02

Ring Assignment : [i/4] - Night Ring

Ln	Ln1	Ln2	Ln3	Ln4	Ln5	Ln6	Ln7	Ln8	Ln9	Ln10	Ln11	Ln12
(10)	Yes	Yes	Yes	Yes	Yes	Yes	Yes	Yes	Yes	Yes	Yes	Yes
(11)	No	No	No	No	No	No	No	No	No	No	No	No
(12)	No	No	No	No	No	No	No	No	No	No	No	No
(13)	No	No	No	No	No	No	No	No	No	No	No	No
(14)	No	No	No	No	No	No	No	No	No	No	No	No
(15)	No	No	No	No	No	No	No	No	No	No	No	No
(16)	No	No	No	No	No	No	No	No	No	No	No	No
(17)	No	No	No	No	No	No	No	No	No	No	No	No
(18)	No	No	No	No	No	No	No	No	No	No	No	No
(19)	No	No	No	No	No	No	No	No	No	No	No	No
(20)	No	No	No	No	No	No	No	No	No	No	No	No
(21)	No	No	No	No	No	No	No	No	No	No	No	No
(22)	No	No	No	No	No	No	No	No	No	No	No	No
(23)	No	No	No	No	No	No	No	No	No	No	No	No
(24)	No	No	No	No	No	No	No	No	No	No	No	No
(25)	No	No	No	No	No	No	No	No	No	No	No	No

help F2-Save-N F3-RCV F4-Send F5-Connect F6-Disc F7-BkUp F8-RS232C F9-Modem

Figure 3.4 Ring Assignment Screen III

# REMOTE SYSTEM PROGRAMMING

## 3. DATA BASE PROGRAMMING, con t'd

### 3.2.3 STATION I

This function allows access to the day class, night class, set group number, and zone number da all stations. Figure 3.3 shows the format of the Station I data screen. The data field options are Day Class and Night Class, **1-8** for Set Group number, and 1-2 for Zone number.

The Set column lists the station numbers, which by default have a one-to-one correlation with the system station port numbers: the station port numbers, in parentheses, never change. Note that screens are required to program Station I, which can be toggled through using the PgUp or PgDn

Changes to the screen database settings may be made as follows:

- press the PgUp or PgDn keys to select the desired page
- use the ARROW keys to move cursor to the desired data field
- use the ENTER key to cycle through the data options for the field variable

LANDMARK KSU Revision K12UW0.FXX					
Esc-Exit	Disconnected			03-02-1 995 08:5	
Station I : [1/4]	Set	Day Class	Night Class	Set Group	Zone No.
	10(10) 11(11)	0	0		
	12(12) 13(13)	0	0		
	14(14) 15(15)	0	0		
	16(16) 17(17)	0	0		
	18(18) 19(19)	0	0		1
	20(20) 21(21)	0	0		
	22(22) 23(23)	0	0		
	24(24) 25(25)	0	0		1

F1-Help F2-Save-N F3-RCV F4-Send F5-Connect F6-Disc F7-BkUp F8-RS232C F9-Mod

Figure 3.5 Station I Data Screen

# REMOTE SYSTEM PROGRAMMING

## DATABASE PROGRAMMING, cont'd

### 3.2.4 STATION II

This function allows access to the **Least** Cost Routing (LCR), Intercom (**ICM**) Type, and User Password data fields for all stations. **Figure 3.6** shows the format of the Station II data screen. The data field options are 'Yes' or '**NO**' for enabling or disabling LCR, 'Ring' or 'Voice' for **ICM** Type, and four digits must be entered (0000 - 9999) for User Password.

The Set column lists the station numbers, which by default have a one-to-one correlation with the key system station ports; the station port numbers, in parentheses, never change. Note that four screens are required to program Station II, which can be toggled through by using the **PgUp** or **PgDn** keys.

Changes to the screen database settings may be made as follows:

- press the **PgUp** or **PgDn** keys to select the desired page
- use the ARROW keys to move cursor to the desired data field
- use the **ENTER** key to cycle through the data options for LCR and ICM Type
- enter a four digit number, using the keyboard, for the User Password

LANDMARK KSU Revision **K12UW0.FXX**

c-Exit

Disconnected

03-02-1995 08:51:02

Station II : [1/4]

Set	LCR Enable	ICM Type	User Password
10(10)	No	Ring	0000
11(11)	No	Ring	0000
12(12)	No	Ring	0000
13(13)	No	Ring	0000
14(14)	No	Ring	0000
15(15)	No	Ring	0000
16(16)	No	Ring	0000
17(17)	No	Ring	0000
18(18)	No	Ring	0000
19(19)	No	Ring	0000
20(20)	No	Ring	0000
21(21)	No	Ring	0000
22(22)	No	Ring	0000
23(23)	No	Ring	0000
24(24)	No	Ring	0q00
25(25)	No	Ring	0000

-Help F2-Save-N F3-RCV F4-Send F5-Connect F6-Disc F7-BkUp F8-RS232C F9-Modem

Figure 3.6 Station II Data Screen

# REMOTESYSTEM PROGRAMMING

## 3. DATABASE PROGRAMMING, cont'd

### 3.2.5 STATION III

This function allows access to the system's preprogrammed call forward destinations data for all stations. Figure 3.7 shows the **format** of the Station III data screen. The call forward destinations are **two** digit station numbers **while** the delay time for No Answer Call Forward is also two digits. The **d**. field options for Delay Time are **10, 20, 26,** or 32 seconds (Default: 26 seconds).

The Set column lists the station numbers, which by default have a one-to-one correlation with the **k** system station ports; the station port numbers, in parentheses, never change. Note that four **scree** are required to program the Call Forward features, which can be toggled through by using the **PgU** PgDn keys.

Changes to the screen database settings may be made as follows:

- press the PgUp or PgDn keys to select the desired page
- use the ARROW keys to move cursor to the desired data field
- enter the station number (1 0-81, except the existing station number), via the keyboard Busy To and No Ans To destinations
- use the ENTER key to cycle through the data options for Delay Time

LANDMARK KSU Revision K12UW0.FXX			
Esc-Exit	Disconnected	03-02-1995 08:51	
Station III : [1/4]			F10-Non
Set	Busy To	No_Ans To	Delay Time
10(10)	x x	x x	26
11(11)	x x	x x	26
12(12)	x x	x x	26
13(13)	x x	x x	26
14(14)	x x	x x	26
15(15)	x x	x x	26
16(16)	x x	x x	26
17(17)	x x	x x	26
18(18)	x x	x x	26
19(19)	x x	x x	26
20(20)	x x	x x	26
21(21)	x x	x x	26
22(22)	x x	x x	26
23(23)	x x	x x	26
24(24)	x x	x x	26
25(25)	x x	x x	26

F1-Help F2-Save-N F3-RCV F4-Send F5-Connect F6-Disc F7-BkUp F8-RS232C F9-Mod

Figure 3.7 Station III Data Screen

NOTE: When sending this feature to the KSU, if the corresponding station had enabled **DND,** the the CFW destination(s) will be ignored.

# REMOTE SYSTEM PROGRAMMING

## DATABASE PROGRAMMING, cont'd

### 3.26 STATION IV

This function allows access to the Set (station) Position, Mail Box, User Name, and **DSS/BLF For** data for all stations. Figure 3.8 shows the format of the Station IV data screen. The Set Position (1 0-81, an unoccupied number) and Mail B ox (001-999) numbers are two and three digits in length, respectively, the User Name consists of **ASCII** code with a maximum length of seven characters, and the **DSS/BLF For** is a two digit station number which specifies the station to which a DKS 940 is being connected. No duplicate Station Position, Mail Box number, or **DSS/BLF For** stations are allowed.

The Set column lists the station numbers, which by default have a one-to-one correlation with the key system station port numbers; the station port numbers, in parentheses, never change. Note that four screens are required for programming Station IV functions, which can be toggled through by using the PgUp and PgDown keys

Changes to the screen database settings may be made as follows:

- . press the PgUp or PgDn keys to select the desired page
- . use the ARROW keys to move cursor to the desired data field
- . enter desired digits for Set Position, Mail Box number or **DSS/BLF For**, and enter desired ASCII code for the user name

LANDMARK KSU Revision K12UW0.FXX

-Exit Disconnected 03-02-1995 08:51:02

Station IV : [1/4]		User Name, <b>DSS/BLF For</b>		FI O-None
Set	Position	Mail Box	User Name	<b>DSS/BLF For</b>
0(10)	10	010		x x
1(11)	11	011		x x
2(12)	12	012		x x
3(13)	13	013		x x
4(14)	14	014		x x
5(15)	15	015		XX
6(16)	16	016		x x
7(17)	17	0 1 7		x x
8(18)	18	0 1 8		XX
9(19)	19	019		x x
0(20)	20	020		x x
1(21)	21	021		XX
2(22)	22	022		x x
3(23)	2 3	023		x x
4(24)	24	024		x x
5(25)	25	025		x x

Help F2-Save-N F3-RCV F4-Send F5-Connect F6-Disc F7-BkUp F8-RS232C F9-Modem

Figure 3.8 Station IV Data Screen

# REMOTE SYSTEM PROGRAMMING

## 3. DATABASE PROGRAMMING

### 3.2.7 LINE I

This function allows access to the Dialing mode, Line Type, Line Pool, Day Class, Night Class, Privacy, and Hunt Group Answer data for all C.O. lines. Figure 3.9 shows the format of the Line I data screen. The dialing options are 'Tone' or 'Pulse', the Line Type can be 'C.O.' or 'PBX', the Line pool number can be 1-8, the Day Class and Night Class can be 0-7, Privacy can be 'Yes' or 'No', and Hunt Group Answer can be N (for none) or 1-8.

Changes to the screen database settings may be made as follows:

- use the ARROW keys to move cursor to the desired data field
- use the ENTER key to cycle through the data options for field variable

LANDMARK KSU Revision K12UW0.FXX												
Esc-Exit	Disconnected								03-02-1995 08:51:			
Line I : [i/i]												
	Ln1	Ln2	Ln3	Ln4	Ln5	Ln6	Ln7	Ln8	Ln9	Ln10	Ln11	Ln12
Dialing	Tone	Tone	Tone	Tone	Tone	Tone	Tone	Tone	Tone	Tone	Tone	Tone
Line Type	c o	co	co	co	co	co	co	co	co	co	co	co
Line Pool	1	1	1	1	1	1	1	1	1	1	1	1
Day Class	0	0	0	0	0	0	0	0	0	0	0	0
Night Class	0	0	0	0	0	0	0	0	0	0	0	0
Privacy	Yes	Yes	Yes	Yes	Yes	Yes	Yes	Yes	Yes	Yes	Yes	Yes
Hunt Grp Ans												
Day Mode	N	N	N	N	N	N	N	N	N	N	N	N
Night Mode	N	N	N	N	N	N	N	N	N	N	N	N
<b>F1-Help F2-Save-N F3-RCV F4-Send F5-Connect F6-Disc F7-BkUp F8-RS232C F9-Mod</b>												

Figure 3.9 Line I Data Screen

# REMOTE SYSTEM PROGRAMMING

## DATABASE PROGRAMMING, cont'd

### 2.8 LINE II

This function allows access to the Private To and Delayed Ring data for all C.O. lines. Figure 3.10 shows the format of the Line II data screen. The Private To field is a two-digit station number that must be entered via the keyboard (10-81, an existing station number), Delay Time is a two digit number (0/20/26/32 seconds) whose options can be scrolled through using the ENTER key, Mail Box is a three digit number which must be entered, the Reason and Originator Can be 'Yes' or 'No', and the First and Second Destination can be a station (1 0-81, an existing station number) or hunt group code (82-89 for hunt groups 1-8).

Changes to the screen database settings may be made as follows:

- use the ARROW keys to move cursor to the desired data field
- enter the desired digits for Private To, Mail Box, First Destination, and Second Destination
- use ENTER to cycle through the data options for Ring Time, Reason, and Originator

LANDMARK KSU Revision K12UW0.FXX						
Exit	Disconnected			03-02-1 995 08:51:02		
Line II : [I/]						Fl O-None
	Ln1	Ln2	Ln3	Ln4	Ln5	Ln6
Private To	XX	x x	x x	x x	x x	x x
Delayed Ring						
Delay Time	None	None	None	None	None	None
Mailbox	None	None	None	None	N o n e	None
Reason	No	No	No	No	No	No
Originator	No	No	No	No	No	No
Destination						
First	None	None	None	None	None	None
Second	None	None	None	None	None	None
<b>help F2-Save-N F3-RCV F4-Send F5-Connect F6-Disc F7-BkUp F8-RS232C F9-Modem</b>						

Figure 3.10 Line II Data Screen

# REMOTE SYSTEM PROGRAMMING

## 3. DATABASE PROGRAMMING, cont'd

### 3.2.9 SYSTEM I

This function allows access to the Service Mode, Hour Mode, RMT X Rate (RS232C Data Transmission Rate), SMDR (Station Message Detail Recording) X Rate (Data Transmission Rate), SMDR Output, (Voice Mail) Hunt Group, DSS/SPD Priority, Supervised XFR, Ring On Talk, and One Touch XFR for the system. Figure 3.11 shows the format of the System I data screen. The data options of each field are shown to the right of the field, in parentheses.

Changes to the screen database settings may be made as follows:

- use the ARROW keys to move cursor to the desired data field
- use the ENTER key to cycle through the data options of the field variable

```

LANDMARK KSU Revision K12UW0.FXX
Esc-Exit Disconnected 03-02-1 995 08:51
System I : [I/I] User Name, DSS/BLF For FI O-Non
Service M o d e : Time (Day/Night/Time)
Hour Mode : 12 (12/24 Mode)
RMT X-Rate : 9800 (110/300/600/.../4800/9600/19200)
SMDR X-Rate : 9600 (110/300/600/.../4800/9600/19200)
SMDR Output Incoming Call : Yes (NoNes)
Account Code : Yes (NoNes)
VM Hunt Group : N ( N / I - 8 )
DSS/SPD Priority : SPD (DSS/SPD)
Supervised XFR Ring On XFR : No (NoNes)
Ring On Talk : No (NoNes)
One Touch XFR : No (NoNes)
F1-Help F2-Save-N F3-RCV F4-Send F5-Connect F6-Disc F7-BkUp F8-RS232C F9-Mo
```

Figure 3.11 System I Data Screen

# REMOTE SYSTEM PROGRAMMING

## DATABASE PROGRAMMING, cont'd

### 3.2.10 SYSTEM II

This function allows access to the PBX Code, Attendant station (**10-81**, an existing station number) of Zone 1 and Zone 2, Night Start and Night End, and System Alarm data. Figure 3.12 shows the format of the System II data screen. The options for each data field are shown to the **right** of the field.

Changes to the screen database settings may be made as follows:

- use the ARROW keys to move cursor to the desired data **field**
- enter the desired digits using the keyboard
- to cancel an undesired entry and return to the default value, press **F10**

```
LANDMARK KSU Revision K12UW0.FXX
sc-Exit Disconnected 03-02-1995 08:51:02

System II : [1/1] Attendant/Alarm/Modem Setup F10-None
PBX Code : 9 (0-9/00-99)
Attendant- Zone 1 : 10 (Station No.)
Zone 2 : None (Station No.)
Night Start : None ----- (00:00-23:59)
End : None
System Alarm 1 : None ----- ( 00:00-23:59 )
Alarm 2 : None
Alarm 3 : None
Alarm 4 : None
Alarm 5 : None
Alarm 6 : None
Alarm 7 : None
Alarm 8 : None
Modem Setup String : AT&FE0&Q0S0=3

F1-Help F2-Save-N F3-RCV F4-Send F5-Connect F6-Disc F7-BkUp F8-RS232C F9-Modem
```

Figure 3.12 System II Data Screen

# REMOTE SYSTEM PROGRAMMING

## 3. DATABASE PROGRAMMING, cont'd

### 3.2.11 SYSTEM III

This function allows access to the Flash Time, number of Recall Rings, Pause Time, Tone Time, Long Tones, SLT (Single Line Telephone) Hook Flash, VM (Voice Mail) Header Timing, ABR (Automatic Bu Redial), and Loop Break data for the system. Figure 3.13 shows the format of the System III data screen. The options for each data field are shown to the right of the field.

Changes to the screen database settings may be made as follows:

- use the ARROW keys to move the cursor to the desired data field
- use the ENTER key to cycle through the data options for the field variable-

Esc-Exit		LANDMARK KSU Revision K12UW0.FXX		03-02-1 995 08:51:0	
Disconnected					
System III : [I/]					
Flash	Time	: 0.6	Seconds	(0.1/0.2/.../1.5)	
Recall	Rings	: 3	Rings	( 1/2/.../8)	
Pause	Time	: 2	Seconds	(1.5/2.0/3.5/5.0)	
Tone	Time	: 120	msec	(70/120/150)	
Long	Tones	: 1400	msec	(200/300/.../1500)	
SLT Hook Flash-	Min Time	: 0.3	Seconds	(0.06/0.1/0.2/.../1.4)	
	Max Time	: 0.9	Seconds	(0.1/0.2/.../1.5)	
VM Header Timing-	Tone On	: 120	msec	(90/120/150)	
	Tone Off	: 120	msec	(90/120/150)	
ABR-	Repeat	: 5	Times	(0/1/.../15)	
	Interval	: 60	Seconds	(10/30/60/90/120)	
Loop Break	Service	: Enable		(Disable/Enable)	
	Min Break	: 350	msec	(300/350/.../900)	

Figure 3.13 System III Data Screen

# REMOTE SYSTEM PROGRAMMING

## DATABASE PROGRAMMING, cont'd

### 3.2.12 MONITOR PASSWORD

This function allows access **to** the Monitor Password data for all the station **groups** in the system. Figure 3.14 shows the **format** of the Monitor Password data screen. The **password is shown to the** right of the station group number. The default password code is '4513' for **all** station **groups**.

Changes to the screen database settings may be made as follows:

- use the ARROW keys to move the cursor to the desired data **field**
- enter a four digit password via the keyboard

```
LANDMARK KSU Revision K12UW0.FXX
>-Exit                Disconnected                03-02-1 995 08:51:02

Monitor Password : [1/1]

Station  Group 1  : 4513      ----- ( 4 digits)
          Group 2  : 4513
          Group 3  : 4513
          Group 4  : 4513
          Group 5  : 4513
          Group 6  : 4513
          Group 7  : 4513
          Group 8  : 4513

Help  F2-Save-N  F3-RCV  F4-Send  F5-Connect  F6-Disc  F7-BkUp  F8-RS232C  F9-Modem
```

Figure 3.14 Monitor Password Data Screen

# REMOTE SYSTEM PROGRAMMING

## 3. DATABASE PROGRAMMING, cont'd

### 3.2.13 BOSS/SECRETARY

This function allows access to the Boss/Secretary data for all stations. Figure 3.15 shows the **form** the Boss/Secretary data screen. The options of the field are 'None' or a two-digit station number (lo-f an existing station number). NO duplicate B oss 1 or Boss 2 station numbers are allowed.

The Set column lists the station numbers, which by default have a one-to-one correlation with the key system station port numbers; the station port numbers, in parentheses, never change. Note that two screens are required for programming the Boss/Secretary function, which can be toggled by using the PgUp and PgDn keys.

Changes to the screen database settings may be made as follows:

- press PgUp or PgDn keys to select the desired screen
- use the ARROW keys to move cursor to the desired data field
- enter the desired digits or '0'
- to cancel an undesired entry and return to the default value, press **F10**

LANDMARK KSU Revision **K12UW0.FXX**

Esc-Exit Disconnected 03-02-I 995 08:51:(

Boss/Secretary : [1/2]			FI O-None		
Set	Boss 1	Boss 2	Set	Boss 1	Boss 2
10 (10)	None	None	26 (26)	None	None
11 (11)	None	None	27 (27)	None	None
12 (12)	None	None	28 (28)	None	None
13 (13)	None	None	29 (29)	None	None
<b>14 (14)</b>	None	None	30 (30)	None	None
<b>15 (15)</b>	None	None	31 (31)	None	None
16 (16)	None	None	32 (32)	None	None
17 (17)	None	None	33 (33)	None	None
18 (18)	None	None			
19 (19)	<b>None</b>	None			
<b>20 (20)</b>	None	None			
21 (21)	None	None			
22 (22)	None	None			
23 (23)	None	None			
24 (24)	None	None			
25 (25)	None	None			

F1-Help F2-Save-N F3-RCV F4-Send F5-Connect F6-Disc F7-BkUp F8-RS232C F9-Mod

Figure 3.15 Boss/Secretary Data Screen

# REMOTE SYSTEM PROGRAMMING

## DATABASE PROGRAMMING, cont'd

### 3.2.14 VOICE MAIL

This function allows access to the Reason for Call and VM Access Condition data for the system. Figure 3.16 shows the **format** of the Voice Mail data screen. The options for the data field are shown to the right of the field.

Changes to the screen database settings may be made as follows:

- . use the ARROW keys to move cursor to the desired data field
- . enter the desired digits/symbols/letters for the Reason for Call data field, and
- use the ENTER key to cycle through VM Access Conditions

```
LANDMARK KSU Revision K12UW0.FXX
>-Exit Disconnected 03-02-1 995 08:51:02

Voice Mail : [I/] F1 O-Empty
Reason for Call ----- (EMPTY/1/.../9, *, #, A, B, C, D)
Busy External : 9*1
Direct External : 9
No-Ans External : 9*2
Busy Internal : 9*1
Direct Internal : 9
No-Ans Internal : 9*2
ICM Call : *
XFR Call : EMPTY
Disconnect : D
Initial Call : EMPTY
VM Access Condition ----- (No/Yes)
Reason : No
Originator No

-Help F2-Save-N F3-RCV F4-Send F5-Connect F6-Disc F7-BkUp F8-RS232C F9-Modem
```

Figure 3.16 Voice Mail Data Screen

# REMOTE SYSTEM PROGRAMMING

## 3. DATABASE PROGRAMMING, cont'd

### 3.2.15 Direct Inward System Access (DISA)

This function allows access to the **DISA** Active Line, **DISA** Service, and number of **DISA** Rings data in the system. Figure 3.17 shows the format of the **DISA** data screen.

Changes to the screen database settings may be made as follows:

- use the ARROW keys to move the cursor to the desired data field
- use the ENTER key to cycle through data options for Active Line ('No' or 'Yes'), Service (Day, Night, or **Always**), and **DISA** Rings (1-S)

LANDMARK KSU Revision K12UW0.FXX			
Esc-Exit	Disconnected	03-02-1 995	08:51:1
DISA : [1/1]			
	Active Line	Service	DISA Rings
Line 1 :	No	Day	1
Line 2 :	No	Day	1
Line 3 :	No	Day	1
Line 4 :	No	Day	1
Line 5 :	No	Day	1
Line 6 :	No	Day	1

F1-Help F2-Save-N F3-RCV F4-Send F5-Connect F6-Disc F7-BkUp F8-RS232C F9-Mode

Figure 3.17 DISA Data Screen

# REMOTE SYSTEM PROGRAMMING

## DATABASE PROGRAMMING, cont'd

### 3.2.16 DISA ACCESS CODE

This function allows access to the DISA Access Code and Class Of Service (COS) data for the system. Figure 3.18 shows the format of the DISA data screen.

Changes to the screen database settings may be made as follows:

- use the ARROW keys to move cursor to the desired data field
- enter desired digits for the access code (8 digits), and
- use the ENTER key to cycle through the data options for COS (0-7)

LANDMARK KSU Revision K12UW0.FXX		
sc-Exit	Disconnected	03-02-1 995 08:51:02
DISA Access Code : [1/1]		
F1 O-Empty		
No.	Access Code	COS
1.	Empty	0
2.	Empty	0
3.	Empty	0
4.	Empty	0
5.	Empty	0
6.	Empty	0
7.	Empty	0
8.	Empty	0
9.	Empty	0
10.	Empty	0
11.	Empty	0
12.	Empty	0
No.	Access Code	COS
13 :	Empty	0
14 :	Empty	0
15 :	Empty	0
16 :	Empty	0
17 :	Empty	0
18 :	Empty	0
19 :	Empty	0
20 :	Empty	0
21 :	Empty	0
22 :	Empty	0
23 :	Empty	0
24 :	Empty	0

F1-Help F2-Save-N F3-RCV F4-Send F5-Connect F6-Disc F7-BkUp F8-RS232C F9-Modem

Figure 3.18 DISA Access Code Data Screen

# REMOTE SYSTEM PROGRAMMING

## 3. DATABASE PROGRAMMING, cont'd

### 3.217 EXTERNAL CALL FORWARD (ECF)

This function allows access to the ECF Active Line and Service data for the system. Figure 3.19 shows the format of the ECF data screen. The data field options for both the Active and Service categories can be seen at the bottom of the screen.

Changes to the screen database settings may be made as follows:

- use the ARROW keys to move cursor to the desired data field
- use the ENTER key to cycle through the data options for the ECF Active and ECF Service categories

```

LANDMARK KSU Revision K12UW0.FXX
Esc-Exit Disconnected 03-02-1 995 08:51:02
ECF : [I/]
Active Service
Line 1 : None Day
Line 2 : None Day
Line 3 : None Day
Line 4 : None Day
Line 5 : None Day
Line 6 : None Day
Active : (None/Incoming/Outgoing)
Service : (Day/Night/Always)
F1-Help F2-Save-N F3-RCV F4-Send F5-Connect F6-Disc F7-BkUp F8-RS232C F9-Modem
```

Figure 3.19 ECF Data Screen

# REMOTE SYSTEM PROGRAMMING

## TABASE PROGRAMMING, cont'd

### 18 MESSAGES

Special function allows access to Special Message and Advisory Message programming for the system. Figure 3.20 shows the format of the default message data screen. A message consists of letters, digits, and spaces with a length of up to sixteen characters.

Changes to the screen database settings may be made as follows:

Use the ARROW keys to move cursor to the desired data field  
enter the desired letters/digits/spaces  
to cancel an undesired entry, press **F10**

**NOTE:** Special Messages #1 and #2 are permanent messages. They cannot be changed.

```
LANDMARK KSU Revision K12UW0.FXX
-----
it Disconnected 03-02-1 995 08:51:02
-----
Messages : [I/I] ( A-Z/a-z/0-9/Space) F1 O-Empty
Special Message : -----
1 : CALL BACK
2 : URGENT
3 : CALL OPERATOR
4 : CALL HOME
5 : VISITOR WAITING.
Advisory Message : -----
1 : AT LUNCH
2 : BE BACK SOON
3 : IN A MEETING
4 : OUT OF OFFICE
5 : ON VACATION
-----
F2-Save-N F3-RCV F4-Send F5-Connect F6-Disc F7-BkUp F8-RS232C F9-Modem
```

Figure 3.20 Message Data Screen

# REMOTE SYSTEM PROGRAMMING

## 3. DATABASE PROGRAMMING, cont'd

### 3.2.19 SYSTEM SPEED DIALING (SPD)

There are 75 SPD numbers allowed for the system, which are divided evenly into four groups for convenient display. As shown in Figure 3.21, the system SPD menu screen lists the available group options. When a system Speed Dial group is selected by pressing the corresponding numerical key, the Speed Dial (SPD) data screen is displayed, allowing access to the system SPD numbers for that group. Figure 3.22 shows the format of the system SPD I data screen. A SPD number contains digits and/or the symbols @, P and F with a maximum length of sixteen characters.

Changes to the screen database settings may be made as follows:

- use the ARROW keys to move cursor to the desired data field
- enter the desired digits and/or symbols
- to cancel an undesired entry and return to the default value, press **F10**

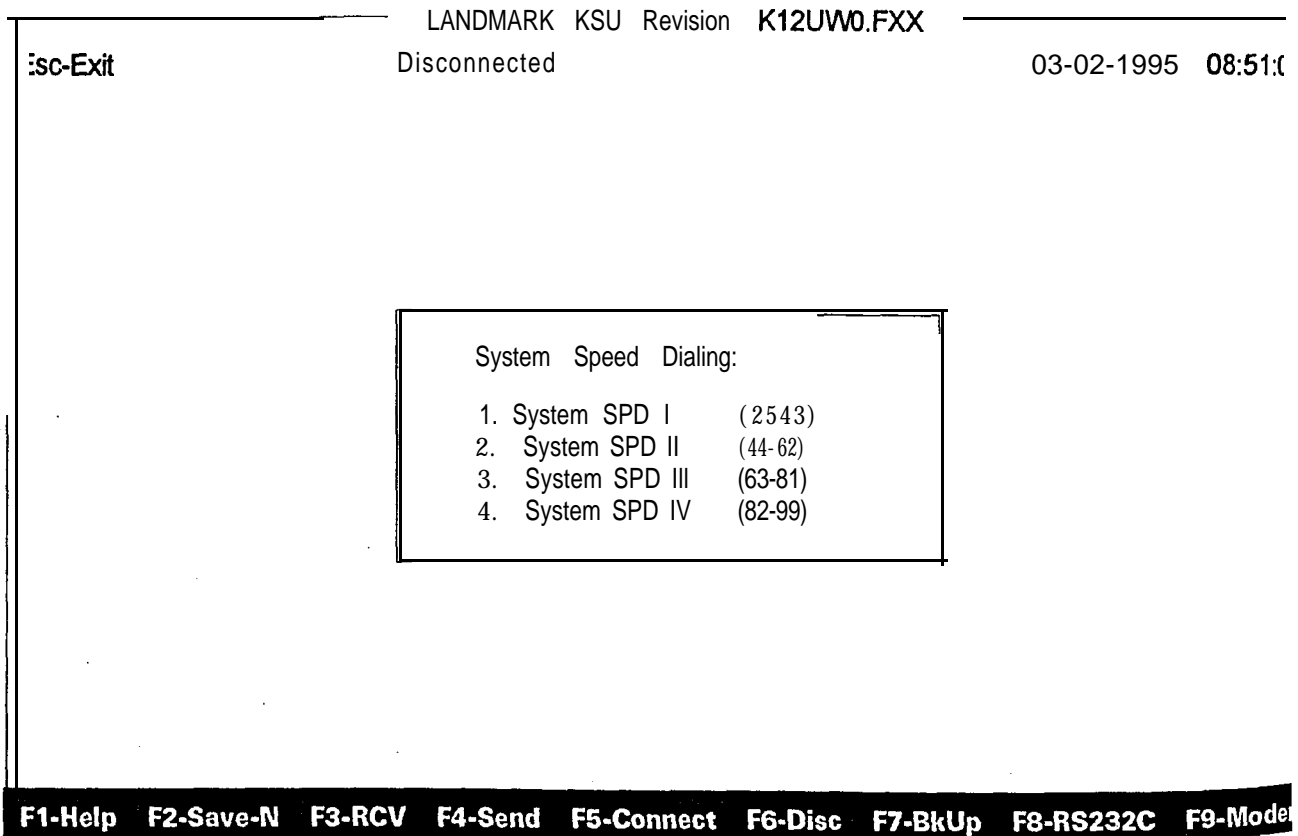

Figure 3.21 System SPD Data Screen

# REMOTE SYSTEM PROGRAMMING

## TABASE PROGRAMMING, cont'd

LANDMARK KSU Revision K12UW0.FXX

kit Disconnected 03-02-1995 08:51:02

tern SPD I : [I] ( Group 25-43 ) → ( 0-9,@,P,F ) F10-Empty

SPD Number	No.	SPD Number
	35.	
	36.	
	37.	
	38.	
	39.	
	40.	
	41.	
	42.	
	43.	

message : @-Chain, P-Pause; F-Flash

lp F2-Save-N F3-RCV F4-Send F5-Connect F6-Disc F7-BkUp F8-RS232C F9-Modem

Figure 3.22 System SPD I Data Screen

# REMOTE SYSTEM PROGRAMMING

## 3. DATABASE PROGRAMMING, cont'd

### 3.2.20 TOLL RESTRICTION

Two types of toll restriction tables **are** defined in the system. They are the Restrict Table and the Exception Table. As shown in Figure 3.23, the Toll Restriction menu screen lists the available type options. When a restriction type is selected by pressing the corresponding numerical key, its data screens are displayed for programming.

These screens are described in the subsequent sections.

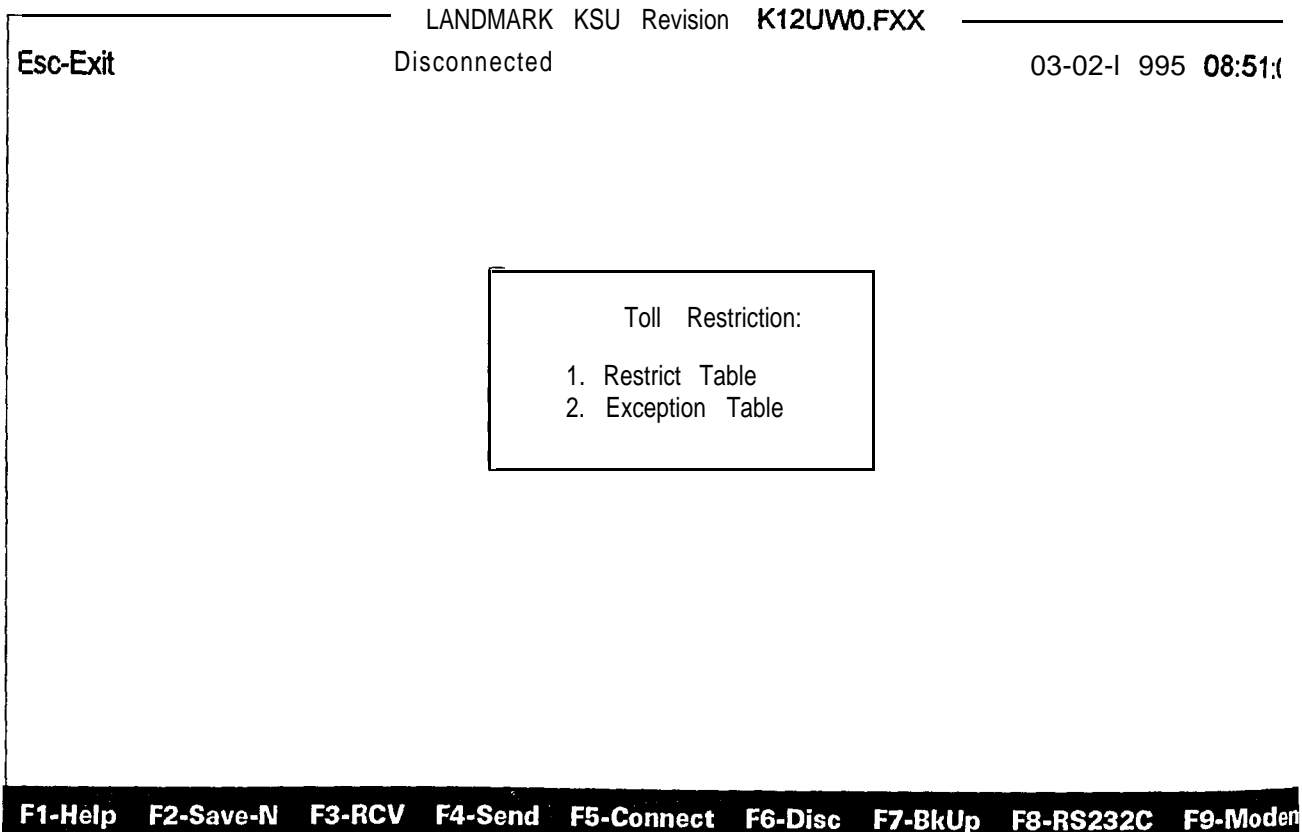

Figure 3.23 Toll Restriction Menu Screen

# REMOTE SYSTEM PROGRAMMING

## TABASE PROGRAMMING, cont'd

### STRICT TABLE

Figure 3.24 shows the format of the Restrict Table data screen, allowing access to 50 entries. The Restrict Number is an 8-digit number, consisting of 0/1/2 . . . /9/ . \*

Note that five screens are required for programming the Restrict Table, which can be toggled through using the PgUp and PgDn keys.

Changes to the screen database settings may be made as follows:

- use the ARROW keys to move cursor to the desired data field
- enter the desired digits for the Restrict Number
- use the ENTER key to cycle through the COS (Class Of Service) data options ('Y' or 'N')
- to cancel an undesired entry and return to the default value, press **F10**

LANDMARK KSU Revision <b>K12UW0.FXX</b>					
Unit	Disconnected	03-02-1 995 08:51:02			
Restriction • Restrict Table : <b>[1/5]</b>					<b>F1</b> O-Empty
Restrict	Station COS			Line COS	
	N u m b e r    Day            Night			Day            Night	
1	(8 digits)    01234567    01234567			01234567    01234567	
	1900    NYNNNNNN    NYNNNNNN			NYNNNNNN    NYNNNNNN	
	1    NNYNNNNN    NNYNNNNN			NNYYNNNN    NNYYNNNN	
	NNYYNNNN    NNYNNNNN			NNWNNNN    NNYNNNNN	
111	NNNYNNNN    NNNYNNNN			NNNYNNNN    NNNYNNNN	
376	NNNYNNNN    NNNYNNNN			NNNYNNNN    NNNYNNNN	
540	NNNYNNNN    NNNYNNNN			NNNYNNNN    NNNYNNNN	
	NNNNNNNN    NNNNNNNN			NNNNNNNN    NNNNNNNN	
	NNNNNNNN    NNNNNNNN			NNNNNNNN    NNNNNNNN	
	NNNNNNNN    NNNNNNNN			NNNNNNNN    NNNNNNNN	
	NNNNNNNN    NNNNNNNN			NNNNNNNN    NNNNNNNN	

F2-Save-N    F3-RCV    F4-Send    F5-Connect    F6-Disc    F7-BkUp    F8-RS232C    F9-Modem

Figure 3.24 Restriction Table Data Screen

# REMOTE SYSTEM PROGRAMMING

## 3. DATABASE PROGRAMMING, cont'd

### EXCEPTION TABLE

Figure 3.25 shows the format of the Exception Table data screen, allowing access to 20 entries. exception number is a **14-digit** number, consisting of **0/1/2 . . . /9/ .\***

Note that two screens are required for programming the Exception Table, which can be toggled thro by using the PgUp and **PgDn** keys.

Changes to the screen database settings may be made as follows:

- use the ARROW keys to move cursor to the desired data field
- enter the desired digits for the Exception Number
- use the ENTER key to cycle through the COS data options ('Y' or 'N')
- to cancel an undesired entry and return to the **default** value, press **F10**

Esc-Exit		LANDMARK KSU Revision <b>K12UW0.FXX</b>														03-02-1 995 08:51:																	
		Disconnected																															
		Toll Restriction ■ Exception Table : <b>[1/2]</b>														<b>F10-Emp</b>																	
Entry	Exception Number (14 digits)	Station COS														Line COS																	
		Day							Night							Day							Night										
		0	1	2	3	4	5	6	7	0	1	2	3	4	5	6	7	0	1	2	3	4	5	6	7	0	1	2	3	4	5	6	7
1																																	
2																																	
3																																	
4																																	
5																																	
6																																	
7																																	
<b>8</b>																																	
9																																	
10																																	

Figure 3.25 Exception Table Data Screen

# REMOTE SYSTEM PROGRAMMING

## DATA BASE PROGRAMMING, continued

### 3.2.21 LEAST COST ROUTING (LCR)

There are several tables which are used to program LCR functions. As shown in **Figure 3.26**, the tables **include**: Digit Comparison Table, Time of Day Table, Line Pools Table, and the Digit Modification Table. These tables have programming screens of their own and will be described in **subsequent sections**.

**Choosing** the LCR tables can be done as follows:

- press the numerical key which corresponds to the LCR table you wish to program

Exit	LANDMARK KSU Revision K12UW0.FXX Disconnected	03-02-1 995 08:51:02
<div style="border: 1px solid black; padding: 10px; width: fit-content; margin: 0 auto;"><p>LCR Program:</p><ol style="list-style-type: none"><li>1. Digit Comparison Table</li><li>2. Time of Day Table (1-10)</li><li>3. Line Pools Table</li><li>4. Digit Modification Table</li></ol></div>		
<b>help F2-Save-N F3-RCV F4-Send F5-Connect F6-Disc F7-BkUp F8-RS232C F9-Modem</b>		

Figure 3.26 LCR Menu Screen

# REMOTE SYSTEM PROGRAMMING

## 3. DATABASE PROGRAMMING, cont'd

### 3.221 LEAST COST ROUTING (LCR), cont'd

#### DIGIT COMPARISON TABLE

Figure 3.27 shows the format of the Digit Comparison Table. There are ten (10) screens associated with the Digit Comparison Table, each with a programmable interval (for comparison against dialed digits) and Time of Day Table. The data options for the Interval Allowed and the Time of Day Table be seen at the bottom of the screen.

6

Changes to the screen database settings may be made as follows:

- press the **PgDn** or **PgUp** keys to select the desired screen
- use the **ARROW** keys to move cursor to the desired data field
- enter the desired **digits** for the Interval Allowed (maximum 14 digits)
- use the **ENTER** key to cycle through the Time of Day Table numbers **(N/01-10)**

LANDMARK KSU Revision <b>K12UW0.FXX</b>										
Esc-Exit	Disconnected					03-02-1 995 08:51:0				
LCR Program - Digit Comparison Table : <b>[N/01-10]</b>										
FI O-Empty										
Interval Allowed			Time of Day Table							
No.	From	To		MON	TUE	WED	THU	FRI	SAT	SUN
1. Empty	Empty	Empty	N	N	N	N	N	N	N	
2. Empty	Empty	Empty	N	N	N	N	N	N	N	
3. Empty	Empty	Empty	N	N	N	N	N	N	N	
4. Empty	Empty	Empty	N	N	N	N	N	N	N	
5. Empty	Empty	Empty	N	N	N	N	N	N	N	
6. Empty	Empty	Empty	N	N	N	N	N	N	N	
7. Empty	Empty	Empty	N	N	N	N	N	N	N	
8. Empty	Empty	Empty	N	N	N	N	N	N	N	
9. Empty	Empty	Empty	N	N	N	N	N	N	N	
10.	Empty	Empty		N	N	N	N	N	N	N
From/To: (0-9,X),			Time of Day Table: (01-10)							
<b>F1-Help F2-Save-N F3-RCV F4-Send F5-Connect F6-Disc F7-BkUp F8-RS232C F9-Modem</b>										

Figure 3.27 Digit Comparison Table Data Screen

# REMOTE SYSTEM PROGRAMMING

## DATABASE PROGRAMMING, cont'd

### 3.2.21 LEAST COST ROUTING (LCR), cont'd

#### TIME OF DAY TABLE

Figure 3.28 shows the Time of Day Table. Choose one of the 10 Time of Day Tables according to your programming needs for LCR.

Choose a menu category as follows:

- press the key (A-J) which corresponds to the Time of Day Table you wish to use
- the selected Time of Day List Table will appear (Figure 3.28a, on next page)

Exit	LANDMARK KSU Revision K12UW0.FXX Disconnected	03-02-1 995 08:51:02
<p>LCR Program : Time of Day Table</p> <ul style="list-style-type: none"><li>A. Time of Day Table 1</li><li>B. Time of Day Table 2</li><li>C. Time of Day Table 3</li><li>D. Time of Day Table 4</li><li>E. Time of Day Table 5</li><li>F. Time of Day Table 6</li><li>G. Time of Day Table 7</li><li>H. Time of Day Table 8</li><li>I. Time of Day Table 9</li><li>J. Time of Day Table 10</li></ul>		
<p>Help F2-Save-N F3-RCV F4-Send F5-Connect F6-Disc F7-BkUp F8-RS232C F9-Modem</p>		

Figure 3.28 Time of Day Table Screen

# REMOTE SYSTEM PROGRAMMING

## 3. DATABASE PROGRAMMING, cont'd

### 3.2.21 LEAST COST ROUTING (LCR), cont'd

#### TIME OF DAY TABLE, cont'd

Figure 3.28a shows the first Time of Day Table data screen. There are 10 Time of Day Tables, with each of the subsequent 9 tables identical to the one below. Use the tables to program the time period necessary for using LCR. The data options for the Time Period and the Line Pools number are located at the bottom of the screen.

Changes to the screen database settings may be made as follows:

- use the ARROW keys to move the cursor to the desired data field
- enter four digits for the time period (use 24 hour mode) and
- use the ENTER key to cycle through the data options for the Line Pools Number

LANDMARK KSU Revision K12UW0.FXX

Esc-Exit                      Disconnected                      03-02-1995    08:51:02

LCR Program - Time of Day Table 1 : [1/1]

No.	Time Period	Line Pools No.
1.	XX:XX	N
2.	XX:XX	N
3.	XX:XX	N
4.	XX:XX	N
5.	XX:XX	N
6.	XX:XX	N

Time Period: (00:00-23:59),      Line Pools No.: (N/1-8)

F1-Help   F2-Save-N   F3-RCV   F4-Send   F5-Connect   F6-Disc   F7-BkUp   F8-RS232C   F9-Modem

Figure 3.28a Time of Day Table Data Screen

# REMOTE SYSTEM PROGRAMMING

## DATABASE PROGRAMMING, cont'd

### 3.2.21 LEAST COST ROUTING (LCR), cont'd

#### LINE POOLS TABLE

Figure 3.29 shows the format of the Line Pools Table. A list of the eight (8) possible pools allows programming for Choice of pool and DMT (Digit Modification Table) No. for each individual pool.

Changes to the screen database settings may be made as follows:

- use the ARROW keys to move cursor to the desired data field
- use the ENTER key to cycle through the data options for the Choice And DMT Number.

LANDMARK KSU Revision K12UW0.FXX

Exit                      Disconnected                      03-02-1995    08:51:02

LCR Program : Line Pools Table [1/1]

No.	Choice				DMT No.			
	1	2	3	4	1	2	3	4
1.	N	N	N	N	N	N	N	N
2.	N	N	N	N	N	N	N	N
3.	N	N	N	N	N	N	N	N
4.	N	N	N	N	N	N	N	N
5.	N	N	N	N	N	N	N	N
6.	N	N	N	N	N	N	N	N
7.	N	N	N	N	N	N	N	N
8.	N	N	N	N	N	N	N	N

help F2-Save-N F3-RCV F4-Send F5-Connect F6-Disc F7-BkUp F8-RS232C F9-Modem

Figure 3.29 Pool List Table Screen

# REMOTE SYSTEM PROGRAMMING

## 3. DATABASE PROGRAMMING, cont'd

### 3.2.21 LEAST COST ROUTING (LCR), cont'd

#### DIGIT MODIFICATION TABLE (DMT)

Figure 3.30 shows the format of the Digit Modification Table. This table allows for the deletion of a amount of digits from the beginning of a dialed number (Deleted Digits) and the insertion of digits at beginning of the number (Inserted Digit).

Changes to the screen database settings may be made as follows:

- use the ARROW keys to move cursor to the desired data field
- enter the desired number of digits to delete and enter the digit(s), if any, you want inserted at the beginning of the number
- to cancel an undesired entry and return to the default value, press F10

LANDMARK KSU Revision K12UW0.FXX

Esc-Exit                      Disconnected                      03-02-1995    08:5

LCR Program : Digit Modification Table [1/1]  
F10-Empty

No.	Deleted Digits	Inserted Digit
1.	N	Empty
2.	N	Empty
3.	N	Empty
4.	N	Empty
5.	N	Empty
6.	N	Empty
7.	N	Empty
8.	N	Empty

F1-Help   F2-Save-N   F3-RCV   F4-Send   F5-Connect   F6-Disc   F7-BkUp   F8-RS232C   F9-Mo

Figure 3.30 Digit Modification Table Screen

# REMOTE SYSTEM PROGRAMMING

## DATABASE PROGRAMMING, cont'd

### 3.2.22 HUNT GROUP

This function allows access to the Hunt Method and Hunt Group Setup data for the system. Figure 3.31 shows the format of the Hunt Group Table. Each station may simultaneously be a member of any of the eight different Hunt Groups.

Changes to the screen database settings may be made as follows:

- use the **ARROW** keys to move cursor to the desired data field
- use the **ENTER** key to cycle through the data options ('First' or 'Next') for Hunt Method
- enter the desired two digit station number (10-81, an existing station number) to be a member of the Hunt Group
- to cancel an undesired entry and return to the default value, press **F10**

LANDMARK KSU Revision K12UW0.FXX

Esc-Exit                      Disconnected                      03-02-1995    08:51:02

---

Hunt Group Setup : [1/1] F10-None

Hunt Method	Group 1 First	Group 2 First	Group 3 First	Group 4 First	Group 5 First	Group 6 First	Group 7 First	Group 8 First
Group Member								
01/13	xx/xx	xx/xx	xx/xx	xx/xx	xx/xx	xx/xx	xx/xx	xx/xx
02/14	xx/xx	xx/xx	xx/xx	xx/xx	xx/xx	xx/xx	xx/xx	xx/xx
03/15	xx/xx	xx/xx	xx/xx	xx/xx	xx/xx	xx/xx	xx/xx	xx/xx
04/16	xx/xx	xx/xx	xx/xx	xx/xx	xx/xx	xx/xx	xx/xx	xx/xx
05/17	xx/xx	xx/xx	xx/xx	xx/xx	xx/xx	xx/xx	xx/xx	xx/xx
06/18	xx/xx	xx/xx	xx/xx	xx/xx	xx/xx	xx/xx	xx/xx	xx/xx
07/19	xx/xx	xx/xx	xx/xx	xx/xx	xx/xx	xx/xx	xx/xx	xx/xx
08/20	xx/xx	xx/xx	xx/xx	xx/xx	xx/xx	xx/xx	xx/xx	xx/xx
09/21	xx/xx	xx/xx	xx/xx	xx/xx	xx/xx	xx/xx	xx/xx	xx/xx
10/22	xx/xx	xx/xx	xx/xx	xx/xx	xx/xx	xx/xx	xx/xx	xx/xx
11/23	xx/xx	xx/xx	xx/xx	xx/xx	xx/xx	xx/xx	xx/xx	xx/xx
12/24	xx/xx	xx/xx	xx/xx	xx/xx	xx/xx	xx/xx	xx/xx	xx/xx

Note: Member - (Station Number)

---

F1-Help    F2-Save-N    F3-RCV    F4-Send    F5-Connect    F6-Disc    F7-BkUp    F8-RS232C    F9-Modem

Figure 3.31 Hunt Group Setup Data Screen

# REMOTE SYSTEM PROGRAMMING

## 3. DATABASE PROGRAMMING, cont'd

### 3.2.23 FEATURE KEY PROGRAMMING

This function allows the programming of the feature keys for each individual station. First, enter station number, whose feature keys you would like to program, as directed by the first Feature K programming screen, Figure 3.32. Then, choose the current DKS keyset you are working with by using the corresponding numerical key, as shown in Figure 3.33.

Once the current phone model is selected, a screen showing the default key layout will be displayed Figure 3.34. Feature key changes will be made on this data screen.

LANDMARK KSU Revision K12UW0.FXX

Esc-Exit                      Disconnected                      03-02-1995 08

Feature Key Programming :  
Please Enter Station Number  
→

F1-Help F2-Save-N F3-RCV F4-Send F5-Connect F6-Disc F7-BkUp F8-RS232C F9-Md

Figure 3.32 Feature Key Programming Screen I

# REMOTE SYSTEM PROGRAMMING

## DATABASE PROGRAMMING, cont'd

### 3.2.23 FEATURE KEY PROGRAMMING, cont'd

SS-

LANDMARK KSU Revision K12UW0.FXX

sc-Exit

Disconnected

03-02-1995 08:51:02

2

Current Phone Model : 935

1. 930
2. 925/935
3. 830

Please Select : (1-3/Esc)

F1-Help F2-Save-N F3-RCV F4-Send F5-Connect F6-Disc F7-BkUp F8-RS232C F9-Modem

Figure 3.33. Feature Key Programming Screen II

# REMOTE SYSTEM PROGRAMMING

## 3. DATABASE PROGRAMMING, cont'd

### 3.2.23 FEATURE KEY PROGRAMMING, cont'd

Figure 3.34 shows the default key status for the DKS 930. The keyset model and station number are displayed in the upper right corner of the screen.

Changes to the screen database settings for any keyset model may be made as follows:

- use the **ARROW** keys to move the cursor to the feature key you wish to change
- press **ENTER** to get a listing, on the screen, of the available key programming possibilities. See Figure 3.35.

```
LANDMARK KSU Revision K12UW0.FXX
Esc-Exit          Disconnected          03-02-1995  08:51:00

Feature Key Programming : [1/1]          Station - 10
                                          Model : 930

1. Line 1      5. F50          10.           16.
2. Line 2      6. F3            11.           17.
3. Line 3      7. F2            12.           18.
4. Line 4      8. F54          13.           19.
9. F8          14.             20.
               15.             21.
```

F1-Help F2-Save-N F3-RCV F4-Send F5-Connect F6-Disc F7-BkUp F8-RS232C F9-Model

Figure 3.34 Feature Key Programming Screen III

# REMOTE SYSTEM PROGRAMMING

## DATABASE PROGRAMMING, cont'd

### 3.2.23 FEATURE KEY PROGRAMMING, cont'd

Figure 3.35 shows the choices with which you may program the feature key. Note that a Data feature key may only be programmed on a DKS 935 keyset. A warning will be displayed on the programming screen if you try to program a Data key on any other keyset model.

Choose one of the four feature programming options:

- press 'A' to program the key as a Line key. Follow the on screen instructions.
- press 'B' to program the key as a Line Pool key. Follow the on screen instructions.
- press 'C' to program the key as a Data key. Follow the on screen instructions.
- press 'D' to program the key as a Feature Access code key. Follow the on screen instructions.

Repeat the steps corresponding to Figure numbers 3.34 and 3.35 to program additional feature keys.

LANDMARK KSU Revision K12UW0.FXX

Exit Disconnected 03-02-1995 08:51:02

Feature Key Programming : [1/1] Station - 10  
Model : 930

1. Line 1	5. F50	10.	16.
2. Line 2	6. F3	11.	17.
3. Line 3	7. F2	12.	18.
4. Line 4	8. F54	13.	19.
9. F8		14.	20.
		15.	21.

A. Line  
B. Line Pool  
C. Data  
D. Fir Access Code

help F2-Save-N F3-RCV F4-Send F5-Connect F6-Disc F7-BkUp F8-RS232C F9-Modem

Figure 3.35 Feature Key Programming Screen IV

# REMOTE SYSTEM PROGRAMMING

## 3. DATABASE PROGRAMMING, cont'd

### 3.2.24 LOUD BELL

This function allows access to the Loud Bell data for all lines and line pools. Figure 3.36 shows the mat of the Loud Bell data screen. Loud Bell Service chooses when the bell is active while it can be turned on or off for any line or line pool. It can also be programmed for a specific station number. data options for the Loud Bell categories are shown at the top right of the screen

Changes to the screen database settings may be made as follows:

- use the **ARROW** keys to move the cursor to the desired data field
- use the **ENTER** key to cycle through the data options for Loud Bell Service, line number, and line pool number
- enter the two digit station number (10-81, an existing station number) where the loud bell should ring

```

                                LANDMARK KSU Revision K12UW0.FXX
-----
Esc-Exit          Disconnected          03-02-1995  08:51
-----
Loud Bell : [1/1]                                     F10-None
                                Line/Pool:(Yes/No), Station:(Station No.)

Loud Bell-  Service : Disable                          (Disable/Day/Night/Always)
            Line 1 : No                                Pool 1   : No
            Line 2 : No                                Pool 2   : No
            Line 3 : No                                Pool 3   : No
            Line 4 : No                                Pool 4   : No
            Line 5 : No                                Pool 5   : No
            Line 6 : No                                Pool 6   : No
                                                    Pool 7   : No
                                                    Pool 8   : No
                                                    Station  : None
-----
F1-Help  F2-Save-N  F3-RCV  F4-Send  F5-Connect  F6-Disc  F7-BkUp  F8-RS232C  F9-Mode

```

Figure 3.36 Loud Bell Data Screen

# REMOTE SYSTEM PROGRAMMING

## DATABASE COMMUNICATION TO THE KSU

### INSTALLATION REQUIREMENTS

#### 4.1.1 ON-SITE PROGRAMMING

Programming can be done from a computer at the same site as the KSU.

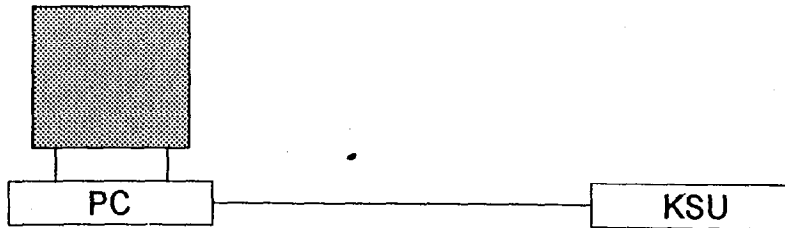

Figure 4.1 On-site Installation Block Diagram

1. Connect the computer serial port to the KSU port labeled 'MODEM'. This port is on the DKS 55 option board.

You will need a cable that matches your computer's serial port connector, whether 9 or 25 pin, male or female, on one end and a 9 pin male connector on the other (KSU) end.

The Remote Program utilizes pins 1-8 and 20 (25 pin connectors) or all 9 pins (9 pin connector). You may need a 25 to 9 pin converter adapter or cable.

2. Go to section 4.2, RS232C PORT SETUP.

#### 4.1.2 OFF-SITE PROGRAMMING

The KSU may be linked to a PC at a remote location by using a telephone line and two modems. The modems must be Hays-command-set compatible.

Since successful operation requires adjustments on both ends, the first attempt may require an operator at both sites.

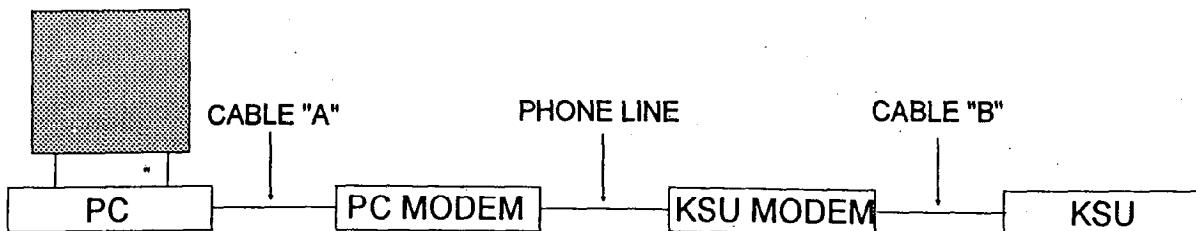

Figure 4.2 Off-site Installation Block Diagram

# REMOTE SYSTEM PROGRAMMING

## 4. DATABASE COMMUNICATION TO THE KSU, cont'd

### 4.1.2 OFF-SITE PROGRAMMING, cont'd

1. (If you have an internal modem, skip to Step 2.)

Connect the serial port of your PC to the 'PC' Modem through cable "A".

You will need a cable that matches your computer's serial port connector, whether 9 or 25 pin, male or female, on one end and a 9 or 25 pin, male or female, connector on the other (modem) end.

The Remote Program utilizes pins 1-8 and 20 (25 pin connectors) or all 9 pins (9 pin connectors). You may need a 25 to 9 pin converter adapter or cable.

2. Connect the modem to the telephone line.
3. Connect the KSU to the 'KSU' modem through cable "B". The KSU port is on the DKS 55 option.

The cable for this connection must match the modem's port connector, whether 9 or 25 pin, male or female, on one end and a 9 pin male connector on the other (KSU) end. The connector needs to be cross-wired as shown in the following table; cross wiring may be accomplished by using a cable "null-modem" adapter.

KSU (9 pin) Pin Number	Modem (25 pin) Pin Number
1	20
2	2
3	3
4	6,8
5	7
6	20
7	5
8	4
9	not used

**NOTE:** If your modem has a 9 pin port, use the cable as outlined above, coupled with a 9 to 25 pin adapter.

4. Connect the 'KSU' modem to the telephone line.
5. Set the 'KSU' modem to "Auto Answer on Ring".

If your modem does not have a switch for "Auto Answer", you may set it up by pressing F78 or Executive keyset. The display will show the current modem setup string. The default string is:

AT&FE0&Q0S0=3

Press: SEND soft key to send the string to the KSU system.

To change the modem setup string, see SYSTEM PROGRAMMING - PERIPHERAL/MODEM SETUP (5.6.6).

6. Set the KSU's bit rate (see System Programming-Peripheral/ RMT X-Rate (RS232C Data Transmission Rate), section 5.6.2). The KSU rate must match the calling PC's serial port rate. To set the PC port rate, see section 4.2, RS232C PORT SETUP.

# REMOTE SYSTEM PROGRAMMING

## DATABASE COMMUNICATION TO THE KSU, cont'd

### RS232C PORT SETUP

Proper parameters for the RS232C port must be established since all data is sent and received through the KSU via this serial port. This procedure is initiated by pressing the function key F8. A small menu window, as shown in Figure 4.3, displays the parameters associated with the RS232C port.

Changes to the screen database settings may be made as follows:

- press the ARROW keys to move cursor to the desired data field
- press ENTER to cycle through the parameters

LANDMARK KSU Revision K12UW0.FXX		
c-Exit	Disconnected	03-02-1995 08:51:02
To set the RS 232C communication port:		
Serial Port	: Com2	(Com1/Com2)
Baud Rate	: 9600	(110/300/600/1200/2400/4800/9600)
Stop Bit	: 1	(1/1.5/2)
Data Bit	: 8	(5/6/7/8)
Parity Check	: No	(Even/Odd/No Parity)

-Help F2-Save-N F3-RCV F4-Send F5-Connect F6-Disc F7-BkUp F8-RS232C F9-Modem

Figure 4.3 RS232C Parameters

**NOTE:** The calling computer's Baud (data) rate must match the rate which is set at the KSU. The KSU has a default Baud rate of 9600. Older computers may need to be set at a lower rate (4800 or less) to accommodate for their slow data transmission and reception ability. In this case, the KSU Baud rate must also be reprogrammed.

To set the KSU modem rate, see System Programming-Peripheral/ RS232C RMT Data Rate, section 5.6.2).

**DEFAULT:** The KSU and PC program's serial port Baud rates are set to 9600 bps.

---

# REMOTE SYSTEM PROGRAMMING

---

## 4. DATABASE COMMUNICATION TO THE KSU, cont'd

### 4.3 MODEM SETUP, DIALING AND LINKING

**NOTE:** If you are programming on-site, please skip this section and go directly to section 4.4, CONNECTION TO THE KSU.

The **F9** function key enables the setup menus for linking your PC through a modem (via telephone line) to the 'KSU' modem, which is directly connected to the KSU.

1. Turn on the power to the modem.
2. Press **F9**.

You will be prompted to select 'Connect' or 'Disconnect'.

3. Select 'Connect' by pressing **ENTER**.

The default modem control string will be displayed on the screen. These characters set up the modem for automatic computer control. The default string shown will set up most Hays-command equivalent modems correctly. It is possible that modems which are not Hays compatible will fail to work properly. The command string may be edited to achieve compatibility before it is sent.

4. Send the command string by pressing **ENTER**.

After the string is sent, the screen will display the dialing mode.

5. Enter the full telephone number of the modem connected to the KSU.
6. Press **ENTER**.

The number will be dialed in pulse mode. If the number must be dialed in tone mode, precede the telephone number with a 'T'.

7. Wait for modems to link successfully.
8. To send hang up commands to the modem, select 'Disconnect' on the first window (see step 2)

### 4.4 SOFTWARE CONNECTION TO THE KSU

Before data can be transmitted between the PC and KSU, a reliable link must be established. Pressing the **F5** function key will initiate the connect request for establishing a link between the computer and the KSU. While the request is in progress, a small window is open to indicate the connection progress.

Use the **Esc** key to exit. There may be a delay in response to the **Esc**.

---

# REMOTE SYSTEM PROGRAMMING

---

## DATABASE COMMUNICATION TO THE KSU, cont'd

---

### SENDING DATA TO THE KSU

Data can be sent to the KSU by using the function key F4. You must first establish a connection before using the Send command. When this function is initiated from a data screen, the screen database should be saved first. Since the data to be sent is from a disk file, saving the screen database ensures that the data on the disk is the latest copy.

The Remote Programming system also automatically saves the current screen database when the Send (F4) function is initiated if the 'Save-Y' option is engaged by using the F2 function key. However, if the 'Save-N' option is engaged and the F4 function key is pressed, the user will be asked if the screen database should or should not be saved if the present copy has not been previously saved.

As soon as the Send function is ready, a small menu window is opened for selecting which database function is to be sent. The listed menu options are:

- 1      Current Function      send database of the current menu group/subgroup to the KSU
- 2      From Current to  
Last Function      send entire database from the current menu group/subgroup  
through the last menu group to the KSU
- 3      All      send database of all menu groups to the KSU

The Send function title and status are shown near the bottom of the window while data transmission (sending) is in progress. It takes approximately five (5) minutes to send all the functions to the KSU.

### RECEIVING DATA FROM THE KSU

Data can be received from the KSU by using the F3 function key. The Receiving function can only be activated after connection to the KSU (see section 4.4). When this function is initiated, a small menu window is opened for selecting which function group of the database is to be received. The listed menu options are:

- 1      Current Function      receive database for current menu group/subgroup
- 2      From Current to  
Last Function      receive database for current menu group/subgroup, plus all  
following groups through the last menu group
- 3      All      receive data for all menu groups

The Receiving function title and status are shown near the bottom of the window while data transmission (reception) is in progress. The received data is automatically saved to the designated disk file.

Use the Esc key to exit.

# REMOTE SYSTEM PROGRAMMING

## 4. DATABASE COMMUNICATION TO THE KSU, cont'd

### 4.7 BACKING UP (AND RESTORING) KSU SETTINGS

#### BACKING UP DATA

The complete database is saved or retrieved from the disk by using the F7 function key. Different K setups can be stored for future use by using different path names when backing up.

1. Press F7.
2. Select Backup by pressing '1'
3. Enter the path name (drive, directory, and filename) in which you want to save the database.

The KSU information presently active will be saved according to the path name specified.

#### RESTORING BACKED UP DATA

1. Press F7.
2. Select Restore by pressing '2'
3. Enter the path name where the files were previously backed up. The backed up files will then be copied to the active directory, where they may be edited.

The database is stored as a group of files with names that are of the form: DK---.DAT. The database and the programs occupy approximately 100K of disk space.

### 4.8 DISCONNECTING

The disconnect request, releasing the KSU from computer control, is initiated by pressing the F6 function key. A small display window indicates the progress of the disconnection.

If you worked through a modem, select F9 to disconnect before exiting program (see 4.3).

Pressing the Esc key from any of the main menu screens will exit the program. After confirmation, you exit to a DOS prompt.

### 4.9 POTENTIAL PROBLEMS

If a modem does not accept the command string which it is sent, remote programming is not likely to work and the modem must be replaced.

Unless the modems at both ends are the same model, it is possible that they may be incompatible and not allow data transmission. In this case, replace one or both of the modems.

Older PC's may not be able to keep up with a bit rate higher than 4800 bps. Therefore, the bit rates must be reprogrammed for both the KSU and the PC port as described in section 4.2.

Some modem pairs may link but the software connection (F5) may not work. Modem error correction is the usual cause. If this should be your case, try changing the setup strings according to your modem's owner's manual.



---

# TROUBLESHOOTING

## GENERAL

a problem occurs, you may want to check the following items first:

- Is the power supply connected to the system?
- Is there AC power (115 or 230 volts) present at the outlet the power supply is plugged into?
- Are all the printed circuit boards in the DKS 308XL present and connected correctly?
- Is the RAM switch in the ON position?

To perform a **WARM RESET** or **COLD RESET**:

### **WARM RESET**

**NOTE:** No previously programmed system data will be lost following a *warm reset*.

To initiate a *warm reset*, turn the AC power switch off and then turn it on again. The entire system is restarted after the power has been cut off and restored.

If a power failure occurs, programmed data will be protected via an internal battery backup, which protects the memory content for seven days under normal conditions.

### **COLD RESET**

**NOTE:** Following a *cold reset*, all previously programmed system data will be automatically reset at DEFAULT values!

A *cold reset* of the entire system is initiated by turning off AC power to the unit, moving the RAM switch to the RESET position, leaving it there for 30 seconds, returning it to the ON position, and reapplying AC power to the unit.

Following a cold reset, the red system indicator on the DKS 308XL will be on steadily for about ten seconds. When the system is operative again (in DEFAULT mode), the system indicator will start flashing.

---

## **LANDMARK HELPLINE**

a solution can not be found in this Troubleshooting section or if you continue to encounter similar problems with your Landmark system, dial the Southwestern Bell Landmark Helpline:

**1-800-750-1840**

# TROUBLESHOOTING

## 2. HARDWARE FAULT LOCATION

First determine what the complaint affects:

- Entire system-      Check: Power supply  
                                 CPU board  
                                 Board connections

- One station-

Determine if the problem is with the keyset by trading a known good set for the one in question. If it works, then the keyset was defective.

If the problem persists, try connecting the keyset in question to a known good line of a different station. If it works, then the problem is in the original connection (wiring) to the keyset. Check the wiring from the telephone block to the keyset location. If it is OK, check the cable connecting the DKS 308XL to the telephone block.

- A group of three lines or up to eight stations-

Check the corresponding DKS 616 board, its connection to the other circuit boards, and to the telephone block.

- Options (loud bell, external paging, background music, music on hold, remote programming, SMDI)  
Check the wiring to any peripheral equipment.

Check the option board to insure proper volume control settings (see DKS 55 User's Guide).

Check the CPU board, which controls the input/output of the optional devices which are connected to the DKS 308XL.

# TROUBLESHOOTING

## FAULT ELIMINATION PROCEDURES

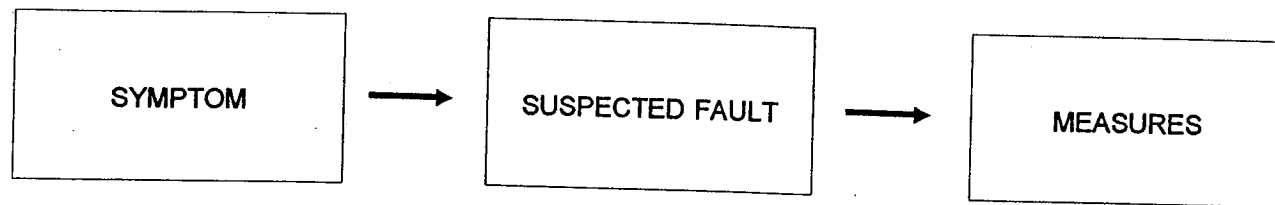

### THE SYSTEM IS INOPERATIVE

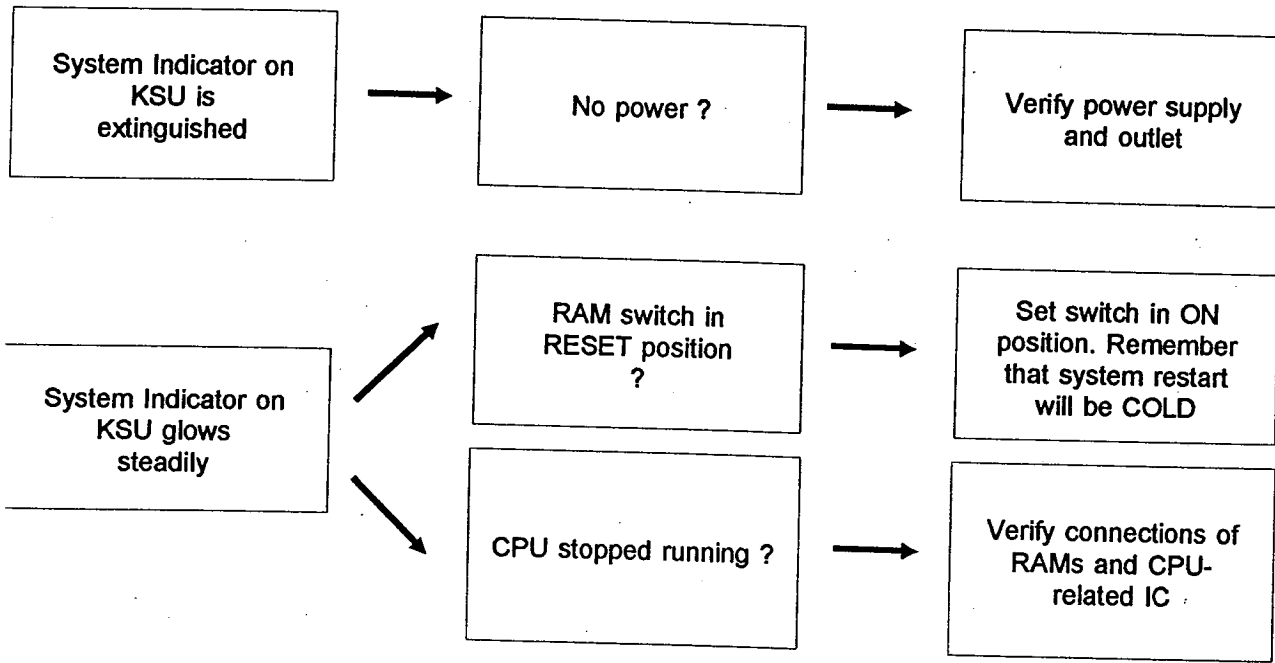

### FAULTS RELATED TO EXTERNAL CALLS

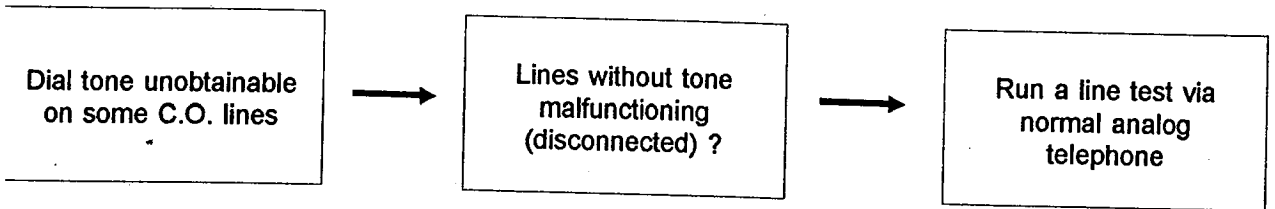

# TROUBLESHOOTING

## 3. FAULT ELIMINATION PROCEDURES, cont'd

### 3.3 TELEPHONES INOPERATIVE

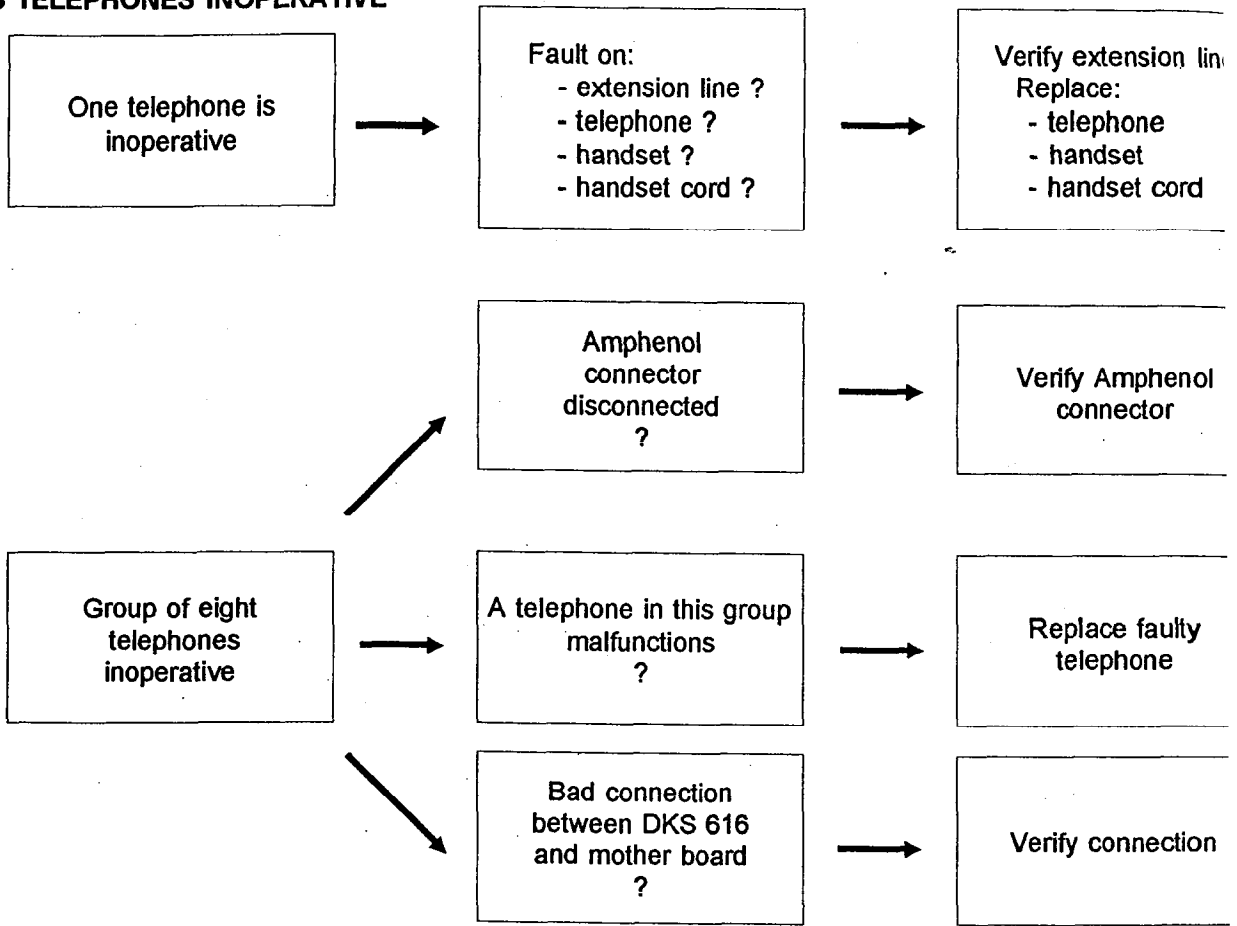

### 3.4 COMMUNICATIONS SUBJECT TO INTERFERENCE

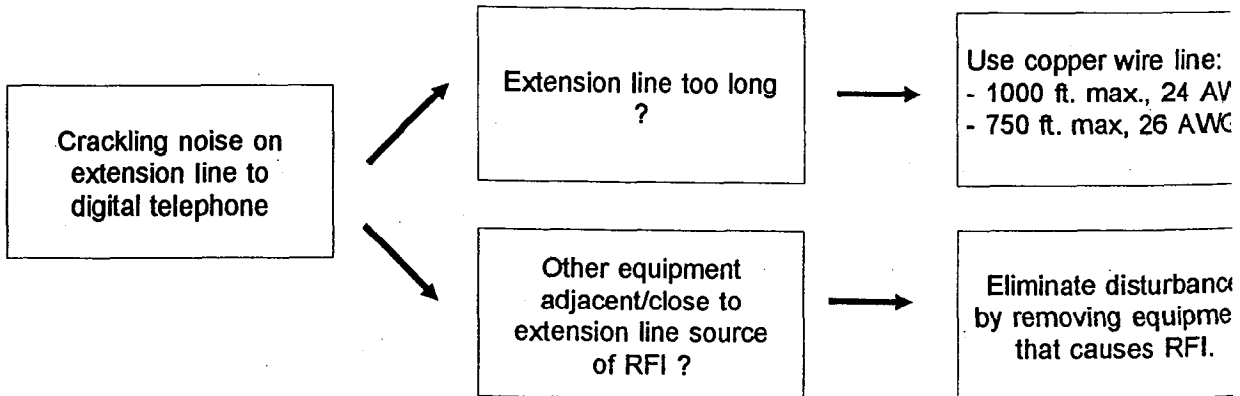

# *APPENDIX A*

# APPENDIX A

## STEM PARAMETER REFERENCE

### CADENCES

#### A. TONE PLAN

##### SIGNAL

##### INDICATION

##### ICM DIAL TONE

(continuous, 425 Hz)

- Be ready to make an ICM call
- 2nd dial tone for DISA (after password)

##### BUSY TONE

(500ms on/off, repeated, 425 Hz)

- Called party is ICM/CO busy

##### RINGBACK TONE

(1 sec on, 3 sec off, repeated, 425 Hz)

- ICM call ringing (waiting for answer)

##### FAST BUSY TONE

(250ms on/off, repeated, 425 Hz)

- Call DND station
- SLT error operation/programming

##### SPECIAL DIAL TONE

(320ms on, 10ms off, repeated, 425 Hz)

- DND/CFW enabled set
- 1st confirmation tone for DISA (after answer)
- C.O. Call on Hold

##### NUMBER UNAVAILABLE TONE

(330ms on, 30ms off, repeated, 950 Hz)

- Call out of service station

##### SERVICE TONE

- Used for feature applications (1400 Hz)
- Conference tone (400 ms)
- SLT programming confirmation tone (1 sec on)

# APPENDIX A

## SYSTEM PARAMETER REFERENCE, cont'd

### B. RING PLAN

#### SIGNAL

#### INDICATION

#### **SILENCE**

- Station is idle

**SLOW RING (External Ring)**  
(2 sec on, 4 sec off, repeated)

- Incoming line call signaling or
- Transferring line call signaling

**FAST RING (Internal Ring)**  
(1 sec on, 2 sec off, repeated)

- Incoming ICM Call signaling

**BEEP**  
(0.5 sec on)

- Reminder indicating completion of a desired feature programming or operation

**DOUBLE BEEP**  
(0.25 sec on/off/on)

- Reminder indicating error or warning operati

**ALERT**  
(0.5 sec on/off/on every 5 seconds,  
lasting for 1 minute)

- Station Alarm Clock Reached

# APPENDIX A

## SYSTEM PARAMETER REFERENCE, cont'd

### C. LAMP PLAN

<u>SIGNAL</u>	<u>INDICATION</u>	(your use)	(other set use as displayed at your set)
<b>DARK</b>	▪ Key not in use		
<b>STEADY LIGHT</b> (Green or Red)	▪ Line in use	(Green)	(Red)
	ICM in use:		
	▪ ICM key lamp	(Green)	
	▪ DSS key lamp	(Red)	(Red)
	▪ In Handsfree mode	(Green)	
	▪ Most Activated Feature keys	(Red)	
<b>SLOW FLASH</b> (1 sec on/off, repeated)	▪ Incoming ICM call signaling		(Green)
	▪ Incoming Data call signaling		(Red)
	▪ Voice Mail Message left (VM key)		(Red)
<b>FAST FLASH</b> (0.25 sec on/off, repeated)	▪ Line call held by yourself		(Green)
	▪ ICM call held by yourself		(Red)
	▪ Data call in progress		(Red)
	▪ Message left (Message Waiting key)		(Red)
<b>FLICKER</b> (0.75 sec on, 0.25 sec off, repeated)	▪ Line call held by others		(Red)
	▪ Message Waiting/ VM Message at any keyset		(ICM lamp)

# APPENDIX A

## SYSTEM PARAMETER REFERENCE, cont'd

### A.2 SYSTEM RESOURCE CAPACITY

<u>FEATURE</u>	<u>CAPACITY</u>
ABR Trials	Fifteen (15) trials
Attendant	Two (2) attendants
Attendant Console	Two (2) sets
Attendant Zone	Two (2) zones
C.O. Lines	Six (6) lines
Class of Service	Eight (8) classes (0/1/2/.../7)
Conference	Four (4) parties
Conference Call	Three (3) groups for the DKS 308XL KSU Seven (7) groups for with DKS 616 Expansion Board
Data Rate Selection	Four (4) types (2400/4800/9600/19200)
DISA Access Code	Twenty-four (24) codes
DISA Lines Allowable	Two (2) lines
Distinctive Station Ring Types	Four (4) types (640, 480 Hz/480, 384 Hz/384, 320 Hz/320, 274.3 Hz)
DTMF Receiver	Two (2) sets
Exception Table	Twenty (20) exceptions
Hold	
Line	Six (6) parties
ICM	One (1) party
Hunt Group	Eight (8) groups
Hunt Group Member	Twenty-four (24) members
Lamp Plan	Four (4) types
LCR Digit Comparison Intervals	One hundred (100) intervals
Line Pool	Eight (8) pools (1 - 8)
Loud Bell	
Set	One (1) set
Line	Six (6) lines

---

## APPENDIX A

---

### SYSTEM PARAMETER REFERENCE, cont'd

<u>FEATURE</u>	<u>CAPACITY</u>
Messages	
Special Message	Five (5) system programmable Two (2) private programmable
Advisory Message	Five (5) system programmable Two (2) private programmable
Message Waiting Buffer	Twenty-four (24) messages
Music Inputs	Two (2): for Music on Hold and Background Music
Power Fail Transfer Circuit	One (1) port per DKS 616 Board Two (2) ports in DKS 308XL with Expansion Board
Restriction Table	Fifty (50) restrictions
Ring Plan	Five (5) types
Single Line Circuit	Sixteen sets per DKS 616 board
Speed Dialing Number (station)	Twenty-four (24) numbers (01 - 24)
Speed Dialing Number (system)	Seventy-four (74) numbers (25 - 98)
Station Group	Eight (8) groups (1 - 8)
System Alarm	Eight (8) alarms
Time of Day List Table	Ten (10) tables
Tone Detector	Two (2) sets
Tone Plan	Seven (7) types
VM Hunt Group	One (1) group

# APPENDIX A

## SYSTEM PARAMETER REFERENCE, cont'd

### A.3 TIME AND COUNT PARAMETER VALUES (Fixed or Programmable)

<u>FEATURE</u>	<u>PARAMETER VALUE(S)</u>
Alarm Clock Alert Ring Duration (station)	1 minute
Alarm with Background Music Listening (system)	1 minute
ABR Interval	10/30/60/90/120 seconds (Default: 60 sec)
Call Again Invoking Time	30 seconds
Call Duration Counter Starts After the Last Digit Dialed	10 seconds
Dial Pulse Interdigit Time	0.6 second
Dial Pulse Make/Break	40 ms / 60 ms
DISA Activation Time	DAY/ NIGHT/ ALWAYS (Default: DAY)
DISA Conversation Time	15 minutes
ECF Activation Time	DAY/ NIGHT/ ALWAYS (Default: DAY)
ECF Conversation Time	7 minutes
Exclusive Hold Time	Unlimited (Changes to Common Hold when Night Service Mode is activated)
Flash Time	0.1/0.2/.../1.5 seconds (Default: 0.6 second)
Hold Reminder Time	60 seconds
Long Tone Time	200/300/.../1500 ms (Default: 1400 ms)
Loop Break Detection Min. Break Time	300/350/.../850/900 ms (Default: 350 ms)
Loud Bell Activation Time	DISABLE/ DAY/ NIGHT/ ALWAYS (Default: Disable)
Message Indication Time for Confirmation or Warning	3 seconds

# APPENDIX A

## STEM PARAMETER REFERENCE, cont'd

<u>FEATURE</u>	<u>PARAMETER VALUE(S)</u>
Pause Time	1.5/2.0/3.5/5.0 seconds (Default: 2 seconds)
Recall Rings	1-8 rings (Default: 3 rings)
Ring Abandon Time	4 seconds
Ring Recognition Time	0.1 second
SLT Hook Flash	
Minimum Time	60/100/200/.../1400 ms (Default: 300 ms)
Maximum Time	100/200/.../1500 ms (Default: 900 ms)
Tone Duration Time	70/120/150 milliseconds (Default: 120 ms)
VM Header	
Tone Time	90/120/150 ms (Default: 120 ms)
Interdigit Time	90/120/150 ms (Default: 120 ms)

## COUNT PARAMETER VALUES (Fixed or Maximum)

<u>FEATURE</u>	<u>PARAMETER VALUE(S)</u>
Account Code (Unverified)	8 digits
Last Number Redial	31 digits
Maximum Dialed Digits Allowed (Manual)	Unlimited
Modem Setup String	16 characters
Monitoring Password	4 digits
Saved Number Redial	31 digits
Special Message	16 characters
Speed Dialing	16 digits

# APPENDIX A

## SYSTEM PARAMETER REFERENCE, cont'd

<u>FEATURE</u>	<u>PARAMETER VALUE(S)</u>
Station Password for Station Lock/Unlock	4 digits
System Password for Data Base Programming Entry	6 digits
User Name	7 characters

### **A.5 FACILITY INTERFACE AND SERVICE ORDER CODES**

Facility Interface Codes for Analog Private Facilities  
FIC: 02LS2

Service Order Codes for Analog Network Services  
SOC: 9.OY

# *APPENDIX B*

# APPENDIX B

## FEATURE OPERATION SUMMARY

### 3.1 SUMMARY OF PROFESSIONAL KEYSER FEATURE OPERATION AND PROGRAMMING :

F - FEATURE KEY  
RLS - RELEASE KEY  
SPD - SPEED DIAL KEY  
\* - YOU MUST BE ON A CALL TO USE THIS FEATURE  
RC - RETRIEVAL CODE (10-25)  
SN - STATION NUMBER

	<u>ACTIVATE</u>	<u>CANCEL</u>
* ACCOUNT CODE	F71	----
ADVISORY MESSAGE	F90	F*90
AUTO DATA CALL ANSWER	F99	F*99
ALARM CLOCK	F92	F*92
AUTOMATIC BUSY REDIAL (ABR)	F75	F*75
AUTOMATIC HOLD	F94	F*94
AUTOMATIC LINE SELECTION	F95	----
BACKGROUND MUSIC	F52	F*52
* CALL AGAIN	F91	F*91
CALL FORWARD	F2	----
CALL MONITORING	F73	F*73
* CALL PARK	F53 - RC	----
CALL PARK ANSWER	F58 - RC	----
* CAMP ON BUSY LINE	F93	F*93
* CONFERENCE (REFER TO USER'S GUIDE)	F6	----
DATA BASE PROGRAMMING	F#*	RLS
DATA RATE SELECTION	F79	RLS
DEFAULT SETTING (STATION)	F76	----
DISTINCTIVE RING SELECTION	F#7	RLS
DO NOT DISTURB (DND)	F4	F*4
* EXCLUSIVE HOLD	F-HOLD	HOLD
FEATURE KEY PROGRAMMING	F#3	RLS

# APPENDIX B

## FEATURE OPERATION SUMMARY, cont'd

	<u>ACTIVATE</u>	<u>CANCEL</u>
* FLASH	F3	----
GROUP CALL PICKUP	F54	----
LAST NUMBER REDIAL	F8	----
LCD CONTRAST LEVEL ADJUSTMENT	F55-VOL	----
LEAST COST ROUTING (LCR)	F9# or INTERCOM-9	----
* LONG DTMF TONES	F72	----
MENU OF STATION FEATURES & CODES	F0	RLS
MESSAGE WAITING	F96 - SN	F*96 - SN or F*96*
MODEM SETUP	F78	F*78
* MUTE	F77	F*77
PAGING	F50	----
PAGING ANSWER	F59	----
* PAUSE	F70	----
PASSWORD CHANGE	F97	----
SAVED NUMBER REDIAL		
*TO STORE	F51	----
TO REDIAL	F51	----
SPEED DIAL PROGRAMMING	F1	RLS
SPEED DIALING (SYSTEM NUMBERS)	LINE KEY - F1	----
SPEED DIALING (STATION NUMBERS)	SPD	----
STATION FEATURE STATUS CHECK	F#8	RLS
STATION LOCK/UNLOCK	F97	----
SYSTEM SERVICE MODE (ATTENDANT ONLY)	F#0	RLS
VOICE CALL ALLOW	F98	F*98
VOICE MAIL	F9*	----

# APPENDIX B

## FEATURE OPERATION SUMMARY, cont'd

### 1.2 SUMMARY OF ASSOCIATE KEYS SET FEATURE OPERATION AND PROGRAMMING :

F	-	FEATURE KEY
SN	-	STATION NUMBER
GN	-	GROUP NUMBER
PN	-	POOL NUMBER (1-8)
SPD	-	SPEED DIAL
RC	-	RETRIEVAL CODE
PSWD	-	PASSWORD
HH-MM	-	HOURS (00-23) - MINUTES (00-59)
LN	-	LINE NUMBER (1-6)
CODE	-	(01 - 24) - STATION SPD LOCATIONS (25 - 98) - SYSTEM SPD LOCATIONS
*	-	YOU MUST BE ON A CALL TO USE THIS FEATURE

	<u>ACTIVATE</u>	<u>CANCEL</u>
* ACCOUNT CODE	F71 - code - *	----
ALARM CLOCK	F92	F*92
AUTOMATIC BUSY REDIAL (ABR)	F75	F*75
AUTOMATIC HOLD	F94	F*94
AUTOMATIC LINE SELECTION:		
SELECT ANY IDLE LINE	F9500	----
SELECT LINE POOL 1 - 8	F95-0-PN	----
SELECT INTERCOM	F951	----
SELECT LINE 1 - 6	F952-LN	----
BACKGROUND MUSIC	F52	F*52
* CALL AGAIN	F91	F*91
CALL MONITORING	F73	RLS
* CALL PARK	F53-RC	----
CALL PARK ANSWER	F58-RC	----
CAMP ON BUSY LINE	F93	F*93
* CONFERENCE (REFER TO USER'S GUIDE)	F6	----
* CONFERENCE FORCED RELEASE	F74-SN	----
* CONFERENCE PRIVATE TALK	F57-SN	F6
DEFAULT SETTING (STATION)	F76-PSWD	----

# APPENDIX B

## FEATURE OPERATION SUMMARY, cont'd

	<u>ACTIVATE</u>	<u>CANCEL</u>
DISTINCTIVE RING SELECTION	F#7 + 1/2/3/4	----
* EXCLUSIVE HOLD	F-HOLD	HOLD
* FLASH	F3	----
GROUP CALL PICKUP	F54	----
HOLD RETRIEVE	HOLD key or F-0-LN	----
LEAST COST ROUTING (LCR)	F9# or INTERCOM-9 (if LCR enabled)	----
LINE ACCESS LINES 1-6 POOL	F-0-LN or INTERCOM-9 (if LCR not enabled)	----
* LONG DTMF TONES	F72	----
MESSAGE WAITING	F96-SN	F*96-SN or F*96-*
MESSAGE WAITING REPLY	INTERCOM-#	INTERCOM-*
MODEM SETUP	F78	F*78
* OFF HOOK VOICE ANNOUNCE (OHVA)	F56	----
PAGING		
VOICE PAGING	F500-SN	----
ALL (INT + EXT) PAGING	F501	----
INTERNAL PAGING	F502	----
EXTERNAL PAGING	F503	----
GROUP PAGING	F504-GN	----
PAGING ANSWER	F59	----
* PAUSE	F70	----
PASSWORD CHANGE	F97-OLD PSWD-NEW PSWD	----
SAVED NUMBER REDIAL		
*TO STORE (AFTER DIALING)	F51	----
TO REDIAL	F51	----
SPEED DIAL PROGRAMMING	F1-CODE-Number-HOLD	F1-CODE-HOLD
SPEED DIALING	LINE-F1-CODE	----
STATION LOCK	F97-PSWD-#	F97-PSWD-*
VOICE CALL ALLOW	F98	F*98
VOICE MAIL	F9*	----

# APPENDIX B

## FEATURE OPERATION SUMMARY, cont'd

### B.3 SUMMARY OF SINGLE LINE TELEPHONE FEATURE OPERATION AND PROGRAMMING :

OH	-	OFF HOOK
LN	-	LINE NUMBER (1-6)
SN	-	STATION NUMBER
GN	-	GROUP NUMBER
PN	-	POOL NUMBER (1-8)
PSWD	-	PASSWORD
SHF	-	SWITCH HOOK FLASH
HH-MM	-	HOURS (00-23) - MINUTES (00-59)
CODE	-	(01 - 24) - STATION SPD LOCATIONS (25 - 98) - SYSTEM SPD LOCATIONS
SPD	-	SPEED DIAL
*	-	YOU MUST BE ON A CALL TO USE THIS FEATURE

	<u>ACTIVATE</u>	<u>CANCEL</u>
ALARM CLOCK	OH-#92-HH-MM	OH-#*92
AUTOMATIC LINE SELECTION		
SELECT ANY IDLE LINE	OH-#9500	----
SELECT LINE POOL (1-8)	OH-#950-PN	----
SELECT INTERCOM	OH-#951	----
SELECT LINE (1-6)	OH-#952-LN	----
* CALL AGAIN	#91	OH-#*91
CALL MONITORING	OH-#73	----
* CAMP ON BUSY LINE	#93	OH-#*93
DEFAULT SETTING	OH-#76-PSWD	----
GROUP CALL PICKUP	OH-#54	----
HOLD	SHF	SHF
HOLD RETRIEVE (CALL HELD BY DIFFERENT STATION)	OH-#6-SN or OH-#0-LN	----
LAST NUMBER REDIAL	OH-#8	----
LCR ACCESS (if enabled)	OH-9	
LINE ACCESS		
LINE (1 - 6)	OH-#0-LN	----
POOL	OH-#30 or OH-9 (if LCR is not enabled)	----

# APPENDIX B

## FEATURE OPERATION SUMMARY, cont'd

	<u>ACTIVATE</u>	<u>CANCEL</u>
LINE ACCESS (cont'd)		
POOL 1	OH-#31	----
POOL 2	OH-#32	----
POOL 3	OH-#33	----
POOL 4	OH-#34	----
POOL 5	OH-#35	----
POOL 6	OH-#36	----
POOL 7	OH-#37	----
POOL 8	OH-#38	----
<b>NOTE:</b> OH-9 may be used to activate Pool (any line) if LCR is not enabled.		
MESSAGE WAITING	OH-#96-SN	OH-#*96-SN, or OH-#*96-*
* OFF HOOK VOICE ANNOUNCE	#56	----
PAGING:		
VOICE PAGING	OH-#500-SN	----
ALL (INT + EXT) PAGING	OH-#501	----
INTERNAL PAGING	OH-#502	----
EXTERNAL PAGING	OH-#503	----
GROUP PAGING	OH-#504-GN	----
PAGING ANSWER	OH-#59	----
PASSWORD CHANGE	OH-#97-PSWD-New PSWD	----
SPEED DIAL PROGRAMMING	OH-#1-CODE-Number-SHF	OH-#1-CODE-SHF
SPEED DIALING	OH-##-CODE	----
STATION LOCK	OH-#97-PSWD-#	OH-#97-PSWD-*
VOICE MAIL	OH-#9*	----

# APPENDIX B

## FEATURE OPERATION SUMMARY, cont'd

### 4. SYSTEM PROGRAMMING CATEGORIES :

ACTION

RESULT

Data Base Access Code : F#\* + PSWD + SHOW

DB PSWD: 000000  
BKSP SHOW CHG

Press : SHOW

1. SET  
BACK NEXT SHOW

Press : NEXT

2. LINE  
BACK NEXT SHOW

Press : NEXT

3. CALL HANDLING  
BACK NEXT SHOW

Press : NEXT

4. RESOURCE  
BACK NEXT SHOW

Press : NEXT

5. RESTRICTION  
BACK NEXT SHOW

Press : NEXT

6. PERIPHERAL  
BACK NEXT SHOW

# APPENDIX B

## FEATURE OPERATION SUMMARY, cont'd

### B.5 SYSTEM PROGRAMMING SUB-CATEGORIES :

#### SET

Day Class (of Service)  
Night Class (of Service)  
Line Assignment  
Ring Assignment  
Set Group  
Zone Number  
Set Position  
Mail Box  
Call Forward  
DSS/BLF For  
LCR (Least Cost Routing)  
ICM (Intercom) Type

#### LINE

Day Class (of Service)  
Night Class (of Service)  
Dialing  
Line Type  
Line Pool  
Private To  
Privacy  
Hunt Group Ans (Answer)  
Delayed Ring

#### CALL HANDLING

Flash Time  
Recall Rings  
Pause Time  
PBX Code  
Tone Time  
Long Tones  
VM (Voice Mail) Header Timing  
Boss/Secretary  
DISA (Direct Inward System Access)  
DISA Access Code  
External CFW (Call Forward)  
Auto Busy Redial  
Key Priority (DSS/SPD)  
One Touch XFR (Transfer)  
Supervised XFR (Transfer)  
Ring On Talk

#### RESOURCE

System Alarm  
Attendant  
Service Mode (System)  
Night Start  
Night End  
User Names  
System SPD (Speed-Dialing)  
DB PSWD (System Password)  
Monitor Password  
System Time  
Set Copy  
Line Copy  
User Password  
Messages  
Hour Mode  
KSU Revision  
Default Setting (System)  
VM (Voice Mail) Hunt Group  
Hunt Group

#### RESTRICTION

Toll Restriction  
LCR (Least Cost Routing)

#### PERIPHERAL

SMDR (Station Message Detail Recording)  
RMT X-Rate (RS 232C Port Data Rate)  
Loud Bell  
SLT (Single Line Telephone) Hook Flash  
Voice Mail  
Modem Setup  
Loop Break

# PROGRAMMING RECORDS

CUSTOMER NAME \_\_\_\_\_

CUSTOMER ADDRESS \_\_\_\_\_

\_\_\_\_\_

\_\_\_\_\_

TELEPHONE NUMBER \_\_\_\_\_

CUSTOMER CONTACT \_\_\_\_\_

## OPTIONAL EQUIPMENT INSTALLED IN THIS SYSTEM:

DKS 940 DSS/BLF CONSOLES \_\_\_\_\_

MUSIC ON HOLD \_\_\_\_\_

BACKGROUND MUSIC \_\_\_\_\_

EXTERNAL PAGE \_\_\_\_\_

EXTERNAL BELL \_\_\_\_\_

SMDR PRINTER \_\_\_\_\_ BAUD \_\_\_\_\_

MODEM \_\_\_\_\_ PHONE NUMBER \_\_\_\_\_ BAUD \_\_\_\_\_

INSTALLER \_\_\_\_\_

DATE INSTALLED \_\_\_\_\_

# PROGRAMMING RECORDS

**SET CATEGORY**

TO ENTER SYSTEM PROGRAMMING:

ENTER: **FEATURE - # - \* - SYSTEM PASSWORD ( \_ \_ \_ \_ \_ )**

DEFAULT: **BOLD CHARACTERS**

SET	DKS 825 DKS 830	DKS 925 DKS 930	DKS 935	DKS 940	DKS 50	USER NAME	USER PASSWORD	DAY CLASS
						<b>EMPTY</b>	<b>0 0 0 0</b>	<b>0 1 2 3 4 5 6 7</b>
10								<b>0 1 2 3 4 5 6 7</b>
11								<b>0 1 2 3 4 5 6 7</b>
12								<b>0 1 2 3 4 5 6 7</b>
13								<b>0 1 2 3 4 5 6 7</b>
14								<b>0 1 2 3 4 5 6 7</b>
15								<b>0 1 2 3 4 5 6 7</b>
16								<b>0 1 2 3 4 5 6 7</b>
17								<b>0 1 2 3 4 5 6 7</b>
18								<b>0 1 2 3 4 5 6 7</b>
19								<b>0 1 2 3 4 5 6 7</b>
20								<b>0 1 2 3 4 5 6 7</b>
21								<b>0 1 2 3 4 5 6 7</b>
22								<b>0 1 2 3 4 5 6 7</b>
23								<b>0 1 2 3 4 5 6 7</b>
24								<b>0 1 2 3 4 5 6 7</b>
25								<b>0 1 2 3 4 5 6 7</b>







# PROGRAMMING RECORDS

## 2. LINE CATEGORY

DEFAULT: BOLD CHARACTERS

LINE NUMBER	LINE 1	LINE 2	LINE 3	LINE 4	LINE 5	LINE 6
DAY COS	0 1 2 3 4 5 6 7	0 1 2 3 4 5 6 7	0 1 2 3 4 5 6 7	0 1 2 3 4 5 6 7	0 1 2 3 4 5 6 7	0 1 2 3 4 5 6 7
NIGHT COS	0 1 2 3 4 5 6 7	0 1 2 3 4 5 6 7	0 1 2 3 4 5 6 7	0 1 2 3 4 5 6 7	0 1 2 3 4 5 6 7	0 1 2 3 4 5 6 7
DIALING MODE	TONE PULSE	TONE PULSE	TONE PULSE	TONE PULSE	TONE PULSE	TONE PULSE
LINE TYPE	C.O. PBX	C.O. PBX	C.O. PBX	C.O. PBX	C.O. PBX	C.O. PBX
LINE POOL	1 2 3 4 5 6 7 8	1 2 3 4 5 6 7 8	1 2 3 4 5 6 7 8	1 2 3 4 5 6 7 8	1 2 3 4 5 6 7 8	1 2 3 4 5 6 7 8
PRIVACY	Y N	Y N	Y N	Y N	Y N	Y N
PRIVATE LINE TO	NONE EXT # __	NONE EXT # __	NONE EXT # __	NONE EXT # __	NONE EXT # __	NONE EXT # __
HUNT GRP ANSWER (DAY)	NONE 1 2 3 4 5 6 7 8	NONE 1 2 3 4 5 6 7 8	NONE 1 2 3 4 5 6 7 8	NONE 1 2 3 4 5 6 7 8	NONE 1 2 3 4 5 6 7 8	NONE 1 2 3 4 5 6 7 8
HUNT GRP ANSWER (NIGHT)	NONE 1 2 3 4 5 6 7 8	NONE 1 2 3 4 5 6 7 8	NONE 1 2 3 4 5 6 7 8	NONE 1 2 3 4 5 6 7 8	NONE 1 2 3 4 5 6 7 8	NONE 1 2 3 4 5 6 7 8

# PROGRAMMING RECORDS

## 2. LINE CATEGORY, cont'd

DEFAULT: BOLD CHARACTERS

LINE NUMBER	LINE 1	LINE 2	LINE 3	LINE 4	LINE 5	LINE 6
LINE COPY						
DELAY TIME (sec)	N 10 20 26 32	N 10 20 26 32	N 10 20 26 32	N 10 20 26 32	N 10 20 26 32	N 10 20 26
MAILBOX	<b>EMPTY</b> ---	<b>EMPTY</b> ---	<b>EMPTY</b> ---	<b>EMPTY</b> ---	<b>EMPTY</b> ---	<b>EMPTY</b> ---
REASON	N _____	N _____	N _____	N _____	N _____	N _____
ORIGINATOR	N _____	N _____	N _____	N _____	N _____	N _____
DESTINATION FIRST	<b>NONE</b> __	<b>NONE</b> __	<b>NONE</b> __	<b>NONE</b> __	<b>NONE</b> __	<b>NONE</b> __
SECOND	<b>NONE</b> __	<b>NONE</b> __	<b>NONE</b> __	<b>NONE</b> __	<b>NONE</b> __	<b>NONE</b> __

# PROGRAMMING RECORDS

## 3. CALL HANDLING CATEGORY

DEFAULT: BOLD CHARACTERS

FLASH TIME (sec)            0.1 0.2 0.3 0.4 0.5 0.6 0.7 0.8 0.9 1.0 1.1 1.2 1.3 1.4 1.5 1.6

RECALL RINGS                1 2 3 4 5 6 7 8

PAUSE TIME (sec)            1.5 2 3.5 5

PBX CODE                    9            \_\_ (UP TO TWO DIGITS)

TONE TIME (ms)             70 120 150

LONG TONES (ms)            200 300 400 500 600 700 800 900 1000 1100 1200 1300 1400 1500

VOICE MAIL HEADER

    TONE ON (ms)            90 120 150

    TONE OFF (ms)           90 120 150

### BOSS/SECRETARY

SECRETARY:    EXT # \_\_    BOSS 1: NONE / EXT # \_\_    BOSS 2: NONE / EXT # \_\_

SECRETARY:    EXT # \_\_    BOSS 1: NONE / EXT # \_\_    BOSS 2: NONE / EXT # \_\_

SECRETARY:    EXT # \_\_    BOSS 1: NONE / EXT # \_\_    BOSS 2: NONE / EXT # \_\_

SECRETARY:    EXT # \_\_    BOSS 1: NONE / EXT # \_\_    BOSS 2: NONE / EXT # \_\_

SECRETARY:    EXT # \_\_    BOSS 1: NONE / EXT # \_\_    BOSS 2: NONE / EXT # \_\_

### DIRECT INWARD SYSTEM ACCESS (DISA)

	LINE 1	LINE 2	LINE 3	LINE 4	LINE 5	LINE 6
DISA	Y N	Y N	Y N	Y N	Y N	Y N
DISA SERVICE	DAY NIGHT ALWAYS	DAY NIGHT ALWAYS	DAY NIGHT ALWAYS	DAY NIGHT ALWAYS	DAY NIGHT ALWAYS	DAY NIGHT ALWAYS
DISA RINGS	1 2 3 4 5	1 2 3 4 5	1 2 3 4 5	1 2 3 4 5	1 2 3 4 5	1 2 3 4 5



# PROGRAMMING RECORDS

## 4. RESOURCE CATEGORY

DEFAULT: BOLD CHARACTERS

SYSTEM ALARM      ALARM    ALARM    ALARM    ALARM    ALARM    ALARM    ALARM    ALARM  
                    1           2           3           4           5           6           7           8

ALARM            NONE/    NONE/    NONE/    NONE/    NONE/    NONE/    NONE/    NONE/  
SET TIME        \_ \_ \_ \_   \_ \_ \_ \_   \_ \_ \_ \_   \_ \_ \_ \_   \_ \_ \_ \_   \_ \_ \_ \_   \_ \_ \_ \_   \_ \_ \_ \_

ATTENDANT STATION      ZONE 1:      10  
NUMBER:                    ZONE 2:      NONE      \_ \_

SERVICE:                    DAY / NIGHT / TIME

NIGHT START:                NONE / \_ \_ : \_ \_

NIGHT END:                    NONE / \_ \_ : \_ \_

USER NAMES:                 SEE SET CATEGORY RECORD SHEET (page 1 of this section)

SYSTEM SPEED DIAL:         SEE SYSTEM SPEED DIAL RECORD SHEET (page 21 of this section)

SYSTEM PASSWORD:          0 0 0 0 0 0 \_ \_ \_ \_ \_

CALL	GROUP 1	GROUP 2	GROUP 3	GROUP 4	GROUP 5	GROUP 6	GROUP 7	GROUP 8
MONITORING	4513	4513	4513	4513	4513	4513	4513	4513
PASSWORD	_ _ _ _	_ _ _ _	_ _ _ _	_ _ _ _	_ _ _ _	_ _ _ _	_ _ _ _	_ _ _ _

SYSTEM TIME (DEFAULT)    YR: 199\_ / MONTH 06 / DAY 01 / WEEKDAY TUE / HOUR 12 / MIN 00 / AM

SET COPY:    SEE SET CATEGORY, COPY TO (page 4 of this section)

LINE COPY:    SEE LINE COPY (page 6 of this section)

### PROGRAMMABLE MESSAGES

SPECIAL MESSAGES:    CALL BACK    X X

                          URGENT      X X

                          CALL OPERATOR      \_ \_ \_ \_ \_

                          CALL HOME            \_ \_ \_ \_ \_

                          VISITOR WAITING      \_ \_ \_ \_ \_

ADVISORY MESSAGES:    AT LUNCH              \_ \_ \_ \_ \_

                          BE BACK SOON          \_ \_ \_ \_ \_

                          IN A MEETING            \_ \_ \_ \_ \_

                          OUT OF OFFICE            \_ \_ \_ \_ \_

                          ON VACATION             \_ \_ \_ \_ \_

# PROGRAMMING RECORDS

## 4. RESOURCE CATEGORY, cont'd

DEFAULT: BOLD CHARACTERS

HOUR MODE: 12 24

KSU REVISION: \_\_\_\_\_

VOICE MAIL (VM) HUNT GROUP ASSIGNMENT N \_\_\_\_\_

HUNT GRP	GROUP 1	GROUP 2	GROUP 3	GROUP 4	GROUP 5	GROUP 6	GROUP 7	GROUP 8
HUNT METHOD	FIRST NEXT	FIRST NEXT	FIRST NEXT	FIRST NEXT	FIRST NEXT	FIRST NEXT	FIRST NEXT	FIRST NEXT
GROUP MEMBER								
01	--	--	--	--	--	--	--	--
02	--	--	--	--	--	--	--	--
03	--	--	--	--	--	--	--	--
04	--	--	--	--	--	--	--	--
05	--	--	--	--	--	--	--	--
06	--	--	--	--	--	--	--	--
07	--	--	--	--	--	--	--	--
08	--	--	--	--	--	--	--	--
09	--	--	--	--	--	--	--	--
10	--	--	--	--	--	--	--	--
11	--	--	--	--	--	--	--	--
12	--	--	--	--	--	--	--	--
13	--	--	--	--	--	--	--	--
14	--	--	--	--	--	--	--	--
15	--	--	--	--	--	--	--	--
16	--	--	--	--	--	--	--	--
17	--	--	--	--	--	--	--	--
18	--	--	--	--	--	--	--	--
19	--	--	--	--	--	--	--	--
20	--	--	--	--	--	--	--	--
21	--	--	--	--	--	--	--	--
22	--	--	--	--	--	--	--	--
23	--	--	--	--	--	--	--	--
24	--	--	--	--	--	--	--	--

# PROGRAMMING RECORDS

## 5. RESTRICTIONS

DEFAULT: BOLD CHARACTERS

### A. TOLL RESTRICTIONS

ENTRY	RESTRICTION NUMBER 8 DIGITS MAX	STATION COS																	
		DAY COS							NIGHT COS										
		0	1	2	3	4	5	6	7	0	1	2	3	4	5	6	7		
		N	Y	N	Y	N	Y	N	Y	N	Y	N	Y	N	Y	N	Y	N	Y
01	<b>1 900</b>	N	Y	N	N	N	N	N	N	N	N	N	N	N	N	N	N	N	N
02	<b>1</b>	N	N	Y	Y	N	N	N	N	N	N	N	N	N	N	N	N	N	N
03	<b>0</b>	N	N	Y	Y	N	N	N	N	N	N	N	N	N	N	N	N	N	N
04	<b>411</b>	N	N	N	Y	N	N	N	N	N	N	N	N	N	N	N	N	N	N
05	<b>976</b>	N	N	N	Y	N	N	N	N	N	N	N	N	N	N	N	N	N	N
06	<b>540</b>	N	N	N	Y	N	N	N	N	N	N	N	N	N	N	N	N	N	N
07																			
08																			
09																			
10																			
11																			
12																			
13																			
14																			
15																			
16																			
17																			
18																			
19																			
20																			
21																			
22																			
23																			
24																			
25																			
26																			
27																			
28																			
29																			
30																			
31																			
32																			
33																			
34																			
35																			
36																			
37																			
38																			
39																			
40																			
41																			
42																			
43																			
44																			
45																			
46																			
47																			
48																			
49																			
50																			

# PROGRAMMING RECORDS

## 5. RESTRICTIONS, cont'd

DEFAULT: BOLD CHARACTI

### A. TOLL RESTRICTIONS

ENTRY	RESTRICTION NUMBER 8 DIGITS MAX	LINE COS															
		DAY COS							NIGHT COS								
		0	1	2	3	4	5	6	7	0	1	2	3	4	5	6	7
		N	Y	N	Y	N	Y	N	Y	N	Y	N	Y	N	Y	N	Y
01	<b>1 900</b>	N	Y	N	N	N	N	N	N	N	N	N	N	N	N	N	N
02	<b>1</b>	N	N	Y	Y	N	N	N	N	N	N	N	N	N	N	N	N
03	<b>0</b>	N	N	Y	Y	N	N	N	N	N	N	N	N	N	N	N	N
04	<b>411</b>	N	N	N	Y	N	N	N	N	N	N	N	N	N	N	N	N
05	<b>976</b>	N	N	N	Y	N	N	N	N	N	N	N	N	N	N	N	N
06	<b>540</b>	N	N	N	Y	N	N	N	N	N	N	N	N	N	N	N	N
07																	
08																	
09																	
10																	
11																	
12																	
13																	
14																	
15																	
16																	
17																	
18																	
19																	
20																	
21																	
22																	
23																	
24																	
25																	
26																	
27																	
28																	
29																	
30																	
31																	
32																	
33																	
34																	
35																	
36																	
37																	
38																	
39																	
40																	
41																	
42																	
43																	
44																	
45																	
46																	
47																	
48																	
49																	
50																	

# PROGRAMMING RECORDS

## 5. RESTRICTIONS, cont'd

DEFAULT: BOLD CHARACTERS

### B. EXCEPTIONS

ENTRY	EXCEPTION NUMBER (14 DIGITS MAX)	STATION COS															
		DAY COS							NIGHT COS								
		0	1	2	3	4	5	6	7	0	1	2	3	4	5	6	7
		<b>N</b>	<b>Y</b>	<b>N</b>	<b>Y</b>	<b>N</b>	<b>Y</b>	<b>N</b>	<b>Y</b>	<b>N</b>	<b>Y</b>	<b>N</b>	<b>Y</b>	<b>N</b>	<b>Y</b>	<b>N</b>	<b>Y</b>
01																	
02																	
03																	
04																	
05																	
06																	
07																	
08																	
09																	
10																	
11																	
12																	
13																	
14																	
15																	
16																	
17																	
18																	
19																	
20																	

ENTRY	EXCEPTION NUMBER (14 DIGITS MAX)	LINE COS															
		DAY COS							NIGHT COS								
		0	1	2	3	4	5	6	7	0	1	2	3	4	5	6	7
		<b>N</b>	<b>Y</b>	<b>N</b>	<b>Y</b>	<b>N</b>	<b>Y</b>	<b>N</b>	<b>Y</b>	<b>N</b>	<b>Y</b>	<b>N</b>	<b>Y</b>	<b>N</b>	<b>Y</b>	<b>N</b>	<b>Y</b>
01																	
02																	
03																	
04																	
05																	
06																	
07																	
08																	
09																	
10																	
11																	
12																	
13																	
14																	
15																	
16																	
17																	
18																	
19																	
20																	

# PROGRAMMING RECORDS

## 5. RESTRICTIONS, cont'd

### LEAST COST ROUTING (LCR) TABLES

DEFAULT: BOLD CHARAC

#### 1. Digit Comparison Table

No.	Interval Allowed		Time of Day List (use Table No's. 0					
	From (0-9, *X), max. 14 digits	To (0-9, *X), max. 14 digits	Mon.	Tue.	Wed.	Thu.	Fri.	Sat..
001	EMPTY/	EMPTY/	--	--	--	--	--	--
002	EMPTY/	EMPTY/	--	--	--	--	--	--
003	EMPTY/	EMPTY/	--	--	--	--	--	--
004	EMPTY/	EMPTY/	--	--	--	--	--	--
005	EMPTY/	EMPTY/	--	--	--	--	--	--
006	EMPTY/	EMPTY/	--	--	--	--	--	--
007	EMPTY/	EMPTY/	--	--	--	--	--	--
008	EMPTY/	EMPTY/	--	--	--	--	--	--
009	EMPTY/	EMPTY/	--	--	--	--	--	--
010	EMPTY/	EMPTY/	--	--	--	--	--	--
011	EMPTY/	EMPTY/	--	--	--	--	--	--
012	EMPTY/	EMPTY/	--	--	--	--	--	--
013	EMPTY/	EMPTY/	--	--	--	--	--	--
014	EMPTY/	EMPTY/	--	--	--	--	--	--
015	EMPTY/	EMPTY/	--	--	--	--	--	--
016	EMPTY/	EMPTY/	--	--	--	--	--	--
017	EMPTY/	EMPTY/	--	--	--	--	--	--
018	EMPTY/	EMPTY/	--	--	--	--	--	--
019	EMPTY/	EMPTY/	--	--	--	--	--	--
020	EMPTY/	EMPTY/	--	--	--	--	--	--
021	EMPTY/	EMPTY/	--	--	--	--	--	--
022	EMPTY/	EMPTY/	--	--	--	--	--	--
023	EMPTY/	EMPTY/	--	--	--	--	--	--
024	EMPTY/	EMPTY/	--	--	--	--	--	--
025	EMPTY/	EMPTY/	--	--	--	--	--	--
026	EMPTY/	EMPTY/	--	--	--	--	--	--
027	EMPTY/	EMPTY/	--	--	--	--	--	--
028	EMPTY/	EMPTY/	--	--	--	--	--	--
029	EMPTY/	EMPTY/	--	--	--	--	--	--
030	EMPTY/	EMPTY/	--	--	--	--	--	--
031	EMPTY/	EMPTY/	--	--	--	--	--	--
032	EMPTY/	EMPTY/	--	--	--	--	--	--
033	EMPTY/	EMPTY/	--	--	--	--	--	--
034	EMPTY/	EMPTY/	--	--	--	--	--	--

# PROGRAMMING RECORDS

## 5. RESTRICTIONS, cont'd

### 3 LEAST COST ROUTING (LCR) TABLES

DEFAULT: BOLD CHARACTERS

#### 1. Digit Comparison Table, cont'd

No.	Interval Allowed		Time of Day List (use Table No's. 01-10)						
	From (0-9, *X), max. 14 digits	To (0-9, *X), max. 14 digits	Mon.	Tue.	Wed.	Thu.	Fri.	Sat.	Sun.
035	EMPTY/	EMPTY/	--	--	--	--	--	--	--
036	EMPTY/	EMPTY/	--	--	--	--	--	--	--
037	EMPTY/	EMPTY/	--	--	--	--	--	--	--
038	EMPTY/	EMPTY/	--	--	--	--	--	--	--
039	EMPTY/	EMPTY/	--	--	--	--	--	--	--
040	EMPTY/	EMPTY/	--	--	--	--	--	--	--
041	EMPTY/	EMPTY/	--	--	--	--	--	--	--
042	EMPTY/	EMPTY/	--	--	--	--	--	--	--
043	EMPTY/	EMPTY/	--	--	--	--	--	--	--
044	EMPTY/	EMPTY/	--	--	--	--	--	--	--
045	EMPTY/	EMPTY/	--	--	--	--	--	--	--
046	EMPTY/	EMPTY/	--	--	--	--	--	--	--
047	EMPTY/	EMPTY/	--	--	--	--	--	--	--
048	EMPTY/	EMPTY/	--	--	--	--	--	--	--
049	EMPTY/	EMPTY/	--	--	--	--	--	--	--
050	EMPTY/	EMPTY/	--	--	--	--	--	--	--
051	EMPTY/	EMPTY/	--	--	--	--	--	--	--
052	EMPTY/	EMPTY/	--	--	--	--	--	--	--
053	EMPTY/	EMPTY/	--	--	--	--	--	--	--
054	EMPTY/	EMPTY/	--	--	--	--	--	--	--
055	EMPTY/	EMPTY/	--	--	--	--	--	--	--
056	EMPTY/	EMPTY/	--	--	--	--	--	--	--
057	EMPTY/	EMPTY/	--	--	--	--	--	--	--
058	EMPTY/	EMPTY/	--	--	--	--	--	--	--
059	EMPTY/	EMPTY/	--	--	--	--	--	--	--
060	EMPTY/	EMPTY/	--	--	--	--	--	--	--
061	EMPTY/	EMPTY/	--	--	--	--	--	--	--
062	EMPTY/	EMPTY/	--	--	--	--	--	--	--
063	EMPTY/	EMPTY/	--	--	--	--	--	--	--
064	EMPTY/	EMPTY/	--	--	--	--	--	--	--
065	EMPTY/	EMPTY/	--	--	--	--	--	--	--
066	EMPTY/	EMPTY/	--	--	--	--	--	--	--
067	EMPTY/	EMPTY/	--	--	--	--	--	--	--
068	EMPTY/	EMPTY/	--	--	--	--	--	--	--

# PROGRAMMING RECORDS

## 5. RESTRICTIONS, cont'd

### LEAST COST ROUTING (LCR) TABLES

DEFAULT: BOLD CHARACT

#### 1. Digit Comparison Table, cont'd

No.	Interval Allowed		Time of Day List (use Table No's. 01-					
	From (0-9, *X), max. 14 digits	To (0-9, *X), max. 14 digits	Mon.	Tue.	Wed.	Thu.	Fri.	Sat..
069	EMPTY/	EMPTY/	--	--	--	--	--	--
070	EMPTY/	EMPTY/	--	--	--	--	--	--
071	EMPTY/	EMPTY/	--	--	--	--	--	--
072	EMPTY/	EMPTY/	--	--	--	--	--	--
073	EMPTY/	EMPTY/	--	--	--	--	--	--
074	EMPTY/	EMPTY/	--	--	--	--	--	--
075	EMPTY/	EMPTY/	--	--	--	--	--	--
076	EMPTY/	EMPTY/	--	--	--	--	--	--
077	EMPTY/	EMPTY/	--	--	--	--	--	--
078	EMPTY/	EMPTY/	--	--	--	--	--	--
079	EMPTY/	EMPTY/	--	--	--	--	--	--
080	EMPTY/	EMPTY/	--	--	--	--	--	--
081	EMPTY/	EMPTY/	--	--	--	--	--	--
082	EMPTY/	EMPTY/	--	--	--	--	--	--
083	EMPTY/	EMPTY/	--	--	--	--	--	--
084	EMPTY/	EMPTY/	--	--	--	--	--	--
085	EMPTY/	EMPTY/	--	--	--	--	--	--
086	EMPTY/	EMPTY/	--	--	--	--	--	--
087	EMPTY/	EMPTY/	--	--	--	--	--	--
088	EMPTY/	EMPTY/	--	--	--	--	--	--
089	EMPTY/	EMPTY/	--	--	--	--	--	--
090	EMPTY/	EMPTY/	--	--	--	--	--	--
091	EMPTY/	EMPTY/	--	--	--	--	--	--
092	EMPTY/	EMPTY/	--	--	--	--	--	--
093	EMPTY/	EMPTY/	--	--	--	--	--	--
094	EMPTY/	EMPTY/	--	--	--	--	--	--
095	EMPTY/	EMPTY/	--	--	--	--	--	--
096	EMPTY/	EMPTY/	--	--	--	--	--	--
097	EMPTY/	EMPTY/	--	--	--	--	--	--
098	EMPTY/	EMPTY/	--	--	--	--	--	--
099	EMPTY/	EMPTY/	--	--	--	--	--	--
100	EMPTY/	EMPTY/	--	--	--	--	--	--

\* X is a "wild card" variable only available when using Remote Program

# PROGRAMMING RECORDS

## 5. RESTRICTIONS, cont'd

### LEAST COST ROUTING (LCR) TABLES

#### 2. Time of Day List Tables

Table Number 01

	Time Period Hour (00-23) : Minute (00-59)	Pool List Entry Number (1-8)
1	NONE/ __ : __	NONE/ __
2	NONE/ __ : __	NONE/ __
3	NONE/ __ : __	NONE/ __
4	NONE/ __ : __	NONE/ __
5	NONE/ __ : __	NONE/ __
6	NONE/ __ : __	NONE/ __

Table Number 02

	Time Period Hour (00-23) : Minute (00-59)	Pool List Entry Number (1-8)
1	NONE/ __ : __	NONE/ __
2	NONE/ __ : __	NONE/ __
3	NONE/ __ : __	NONE/ __
4	NONE/ __ : __	NONE/ __
5	NONE/ __ : __	NONE/ __
6	NONE/ __ : __	NONE/ __

Table Number 03

	Time Period Hour (00-23) : Minute (00-59)	Pool List Entry Number (1-8)
1	NONE/ __ : __	NONE/ __
2	NONE/ __ : __	NONE/ __
3	NONE/ __ : __	NONE/ __
4	NONE/ __ : __	NONE/ __
5	NONE/ __ : __	NONE/ __
6	NONE/ __ : __	NONE/ __

Table Number 04

	Time Period Hour (00-23) : Minute (00-59)	Pool List Entry Number (1-8)
1	NONE/ __ : __	NONE/ __
2	NONE/ __ : __	NONE/ __
3	NONE/ __ : __	NONE/ __
4	NONE/ __ : __	NONE/ __
5	NONE/ __ : __	NONE/ __
6	NONE/ __ : __	NONE/ __

Table Number 05

	Time Period Hour (00-23) : Minute (00-59)	Pool List Entry Number (1-8)
1	NONE/ __ : __	NONE/ __
2	NONE/ __ : __	NONE/ __
3	NONE/ __ : __	NONE/ __
4	NONE/ __ : __	NONE/ __
5	NONE/ __ : __	NONE/ __
6	NONE/ __ : __	NONE/ __

Table Number 06

	Time Period Hour (00-23) : Minute (00-59)	Pool List Entry Number (1-8)
1	NONE/ __ : __	NONE/ __
2	NONE/ __ : __	NONE/ __
3	NONE/ __ : __	NONE/ __
4	NONE/ __ : __	NONE/ __
5	NONE/ __ : __	NONE/ __
6	NONE/ __ : __	NONE/ __

# PROGRAMMING RECORDS

## 5. RESTRICTIONS, cont'd

### LEAST COST ROUTING (LCR) TABLES

#### 2. Time of Day List Tables, cont'd

Table Number 07

	Time Period Hour (00-23) : Minute (00-59)	Pool List Entry Number (1-8)
1	NONE/ __ : __	NONE/ __
2	NONE/ __ : __	NONE/ __
3	NONE/ __ : __	NONE/ __
4	NONE/ __ : __	NONE/ __
5	NONE/ __ : __	NONE/ __
6	NONE/ __ : __	NONE/ __

Table Number 08

	Time Period Hour (00-23) : Minute (00-59)	Pool List Entry Number (1-8)
1	NONE/ __ : __	NONE/ __
2	NONE/ __ : __	NONE/ __
3	NONE/ __ : __	NONE/ __
4	NONE/ __ : __	NONE/ __
5	NONE/ __ : __	NONE/ __
6	NONE/ __ : __	NONE/ __

Table Number 09

	Time Period Hour (00-23) : Minute (00-59)	Pool List Entry Number (1-8)
1	NONE/ __ : __	NONE/ __
2	NONE/ __ : __	NONE/ __
3	NONE/ __ : __	NONE/ __
4	NONE/ __ : __	NONE/ __
5	NONE/ __ : __	NONE/ __
6	NONE/ __ : __	NONE/ __

Table Number 10

	Time Period Hour (00-23) : Minute (00-59)	Pool List Entry Number (1-8)
1	NONE/ __ : __	NONE/ __
2	NONE/ __ : __	NONE/ __
3	NONE/ __ : __	NONE/ __
4	NONE/ __ : __	NONE/ __
5	NONE/ __ : __	NONE/ __
6	NONE/ __ : __	NONE/ __

#### 3. Pool Table

	Pool Selection							
	Choice (1-8)				DMT No. (1-8)			
	Choice 1	Choice 2	Choice 3	Choice 4	DMT No. 1	DMT No. 2	DMT No. 3	DMT No. 4
1	NONE/ __	NONE/ __	NONE/ __	NONE/ __	NONE/ __	NONE/ __	NONE/ __	NONE/ __
2	NONE/ __	NONE/ __	NONE/ __	NONE/ __	NONE/ __	NONE/ __	NONE/ __	NONE/ __
3	NONE/ __	NONE/ __	NONE/ __	NONE/ __	NONE/ __	NONE/ __	NONE/ __	NONE/ __
4	NONE/ __	NONE/ __	NONE/ __	NONE/ __	NONE/ __	NONE/ __	NONE/ __	NONE/ __
5	NONE/ __	NONE/ __	NONE/ __	NONE/ __	NONE/ __	NONE/ __	NONE/ __	NONE/ __
6	NONE/ __	NONE/ __	NONE/ __	NONE/ __	NONE/ __	NONE/ __	NONE/ __	NONE/ __
7	NONE/ __	NONE/ __	NONE/ __	NONE/ __	NONE/ __	NONE/ __	NONE/ __	NONE/ __
8	NONE/ __	NONE/ __	NONE/ __	NONE/ __	NONE/ __	NONE/ __	NONE/ __	NONE/ __

DMT - Digit Modification Table Entry

# PROGRAMMING RECORDS

## 5. RESTRICTIONS, cont'd

### LEAST COST ROUTING (LCR) TABLES

#### 4. Digit Modification Table

ENTRY NUMBER	NUMBER OF DIGITS TO DELETE (0 - 12)	DIGITS TO INSERT 16 DIGITS MAXIMUM (0 - 9, Pause)
1	---	-----
2	---	-----
3	---	-----
4	---	-----
5	---	-----
6	---	-----
7	---	-----
8	---	-----

# PROGRAMMING RECORDS

## 6. PERIPHERAL CATEGORY

DEFAULT: BOLD CHARACT

SMDR OUTPUT:

INCOMING CALL:	Y	N							
ACCOUNT CODE:	Y	N							
DATA RATE SELECTION:	110	300	600	1200	2400	4800	<b>9600</b>	19200	
SMDR TRANSMIT RATE:	110	300	600	1200	2400	4800	<b>9600</b>	19200	

LOUD BELL: **DISABLE** DAY NIGHT ALWAYS

POOL 1: Y N	POOL 2: Y N	POOL 3: Y N	POOL 4: Y N
POOL 5: Y N	POOL 6: Y N	POOL 7: Y N	POOL 8: Y N
LINE 1: Y N	LINE 2: Y N	LINE 3: Y N	LINE 4: Y N
LINE 5: Y N	LINE 6: Y N		
STATION: NONE			

SINGLE LINE TELEPHONE HOOKFLASH:

MINIMUM TIME:	60	100	200	<b>300</b>	400	500	600	700	800
	900	1000	1100	1200	1300	1400			
MAXIMUM TIME:	100	200	300	400	500	600	700	800	<b>900</b>
	1000	1100	1200	1300	1400	1500			

VOICE MAIL HEADERS (UP TO 5 DIGITS):

BUSY EXTERNAL	<b>9*1</b>	-----
DIRECT EXTERNAL	9	-----
NO ANSWER EXTERNAL	<b>9*2</b>	-----
BUSY INTERNAL	<b>9*1</b>	-----
DIRECT INTERNAL	9	-----
NO ANSWER INTERNAL	<b>9*2</b>	-----
INTERCOM (ICM) CALL	*	-----
TRANSFER (XFR) CALL	EMPTY	-----
DISCONNECT	D	-----
INITIAL	EMPTY	-----

VM ACCESS CONDITIONS: SEND REASON FOR CALL FORWARD: Y N

SEND ORIGINATOR CODE: Y N

MODEM SET UP: **AT&FE0&Q0S0=3** **A T**-----

LOOP BREAK DETECTION:

SERVICE	DISABLE	<b>ENABLE</b>											
MIN BREAK TIME (ms):	300	<b>350</b>	400	450	500	550	600	650	700	750	800	850	90

# PROGRAMMING RECORDS

## 7. SYSTEM SPEED DIAL NUMBERS

- 25 EMPTY/ -----
- 26 EMPTY/ -----
- 27 EMPTY/ -----
- 28 EMPTY/ -----
- 29 EMPTY/ -----
- 30 EMPTY/ -----
- 31 EMPTY/ -----
- 32 EMPTY/ -----
- 33 EMPTY/ -----
- 34 EMPTY/ -----
- 35 EMPTY/ -----
- 36 EMPTY/ -----
- 37 EMPTY/ -----
- 38 EMPTY/ -----
- 39 EMPTY/ -----
- 40 EMPTY/ -----
- 41 EMPTY/ -----
- 42 EMPTY/ -----
- 43 EMPTY/ -----
- 44 EMPTY/ -----
- 45 EMPTY/ -----
- 46 EMPTY/ -----
- 47 EMPTY/ -----
- 48 EMPTY/ -----
- 49 EMPTY/ -----
- 50 EMPTY/ -----
- 51 EMPTY/ -----
- 52 EMPTY/ -----

# PROGRAMMING RECORDS

## 7. SYSTEM SPEED DIAL NUMBERS, cont'd

53 EMPTY/ \_\_\_\_\_  
54 EMPTY/ \_\_\_\_\_  
55 EMPTY/ \_\_\_\_\_  
56 EMPTY/ \_\_\_\_\_  
57 EMPTY/ \_\_\_\_\_  
58 EMPTY/ \_\_\_\_\_  
59 EMPTY/ \_\_\_\_\_  
60 EMPTY/ \_\_\_\_\_  
61 EMPTY/ \_\_\_\_\_  
62 EMPTY/ \_\_\_\_\_  
63 EMPTY/ \_\_\_\_\_  
64 EMPTY/ \_\_\_\_\_  
65 EMPTY/ \_\_\_\_\_  
66 EMPTY/ \_\_\_\_\_  
67 EMPTY/ \_\_\_\_\_  
68 EMPTY/ \_\_\_\_\_  
69 EMPTY/ \_\_\_\_\_  
70 EMPTY/ \_\_\_\_\_  
71 EMPTY/ \_\_\_\_\_  
72 EMPTY/ \_\_\_\_\_  
73 EMPTY/ \_\_\_\_\_  
74 EMPTY/ \_\_\_\_\_  
75 EMPTY/ \_\_\_\_\_  
76 EMPTY/ \_\_\_\_\_  
77 EMPTY/ \_\_\_\_\_  
78 EMPTY/ \_\_\_\_\_  
79 EMPTY/ \_\_\_\_\_  
80 EMPTY/ \_\_\_\_\_

# PROGRAMMING RECORDS

## 7. SYSTEM SPEED DIAL NUMBERS, cont'd

- 81 EMPTY/ -----
- 82 EMPTY/ -----
- 83 EMPTY/ -----
- 84 EMPTY/ -----
- 85 EMPTY/ -----
- 86 EMPTY/ -----
- 87 EMPTY/ -----
- 88 EMPTY/ -----
- 89 EMPTY/ -----
- 90 EMPTY/ -----
- 91 EMPTY/ -----
- 92 EMPTY/ -----
- 93 EMPTY/ -----
- 94 EMPTY/ -----
- 95 EMPTY/ -----
- 96 EMPTY/ -----
- 97 EMPTY/ -----
- 98 EMPTY/ -----
- 99 EMPTY/ ----- (FOR EXTERNAL CALL FORWARD ONLY)



**A to Z KELLATRONICS, Inc.**

**\_\_\_\_\_ Tel: 800.766.3425**  
**email: info@kellatronics.com Fax: 818.773.8899**